

BDP-BX58/S480/S483/S580

RMT-B109A/B109P/B110A/B110P

SERVICE MANUAL

Self Diagnosis
Supported model

Ver. 1.0 2010.12

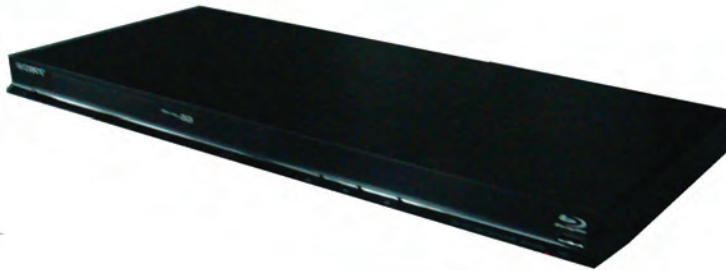

Photo: BDP-S480
Remote : RMT-B109A

Australia/NZ Model
AEP Model
BDP-S480/S580
Latin America Model
BDP-S480/S483

Argentina Model
Korean Model
Indian Model
Middle East Model
Saudi Arabia Model
Taiwan Model
BDP-S480

Canadian Model
US Model
BDP-S480/S580/BX58

UK Model
Brazilian Model
BDP-S480/S580

Russian Model
BDP-S580

SPECIFICATIONS

System

Laser: Semiconductor laser

Inputs and Outputs:

(Jack name: Jack type/Output level/Load impedance)

Line Out R-Audio-L:

Phone jack/2 Vrms/10 kilohms

Digital Out(Coaxial):

Phono jack/0.5 Vp-p/75 ohms

HDMI Out :

HDMI 19-pin standard connector

Component Video out:

(Y, P_B, P_R) :

Phono jack/Y: 1.0 Vp-p/

P_B, P_R : 0.7 Vp-p/75 ohms

Line Out Video:

Phono jack/1.0 Vp-p/75 ohms

LAN (100):

100BASE-TX Terminal

USB:

USB jack Type A (For connecting a USB memory, memory card reader, digital still camera and digital video camera)

Wireless(BDP-S580/BX58 only)

Wireless LAN standard:

IEEE 802.11 b/g/n

Frequency Range:

2.4GHz Band: Channels 1-11 (US, CN, D)

2.4GHz Band: Channels 1-13 (OTHERS)

Modulation:

DSSS and OFDM

General

Power requirements:

120V AC, 60Hz (US, CN, D)

220 - 240V AC, 50/60Hz (AEP, UK, AUS, RUS, I)

110 - 240V AC, 50/60Hz (E, AR, BR, EA, KS, IN)

110V AC, 60Hz (TW)

220V AC, 60Hz (KR)

Power consumption:

20W (BDP-S480/S483)

22W (BDP-S580)

Dimensions (approx.):

430 mm × 199 mm × 36mm

(17 in × 7⁷/₁₆ in × 1⁷/₁₆ in.)

(width/depth/height) incl. projecting parts

Mass (approx.):

1.7 kg

Operating temperature:

5 °C to 35 °C (41 °F to 95 °F)

Operating humidity:

25 % to 80 %

Supplied accessories:

- Audio/video cable (phono plug ×3) (1)
(Except AEP, UK, E, AR, KR, IN, TW, BR)
- LAN cable (1) (BDP-S480 : TW only)
- HDMI cable (1) (BDP-BX58:US)
- Remote commander (remote) (1)
- Size AA (R6) batteries (2)

Specifications and design are subject to change without notice

ENERGY STAR and the ENERGY STAR mark are registered U.S. marks. ENERGY STAR is a registered mark owned by the U.S. government.
(BDP-S480:US/S580:US/BX58:US)

BLU-RAY DISC / DVD PLAYER

SONY



SAFETY CHECK-OUT

After correcting the original service problem, perform the following safety checks before releasing the set to the customer:

1. Check the area of your repair for unsoldered or poorly-soldered connections. Check the entire board surface for solder splashes and bridges.
2. Check the interboard wiring to ensure that no wires are "pinched" or contact high-wattage resistors.
3. Look for unauthorized replacement parts, particularly transistors, that were installed during a previous repair. Point them out to the customer and recommend their replacement.
4. Look for parts which, though functioning, show obvious signs of deterioration. Point them out to the customer and recommend their replacement.
5. Check the line cord for cracks and abrasion. Recommend the replacement of any such line cord to the customer.
6. Check the B+ voltage to see it is at the values specified.
7. Check the antenna terminals, metal trim, "metallized" knobs, screws, and all other exposed metal parts for AC leakage. Check leakage as described below.

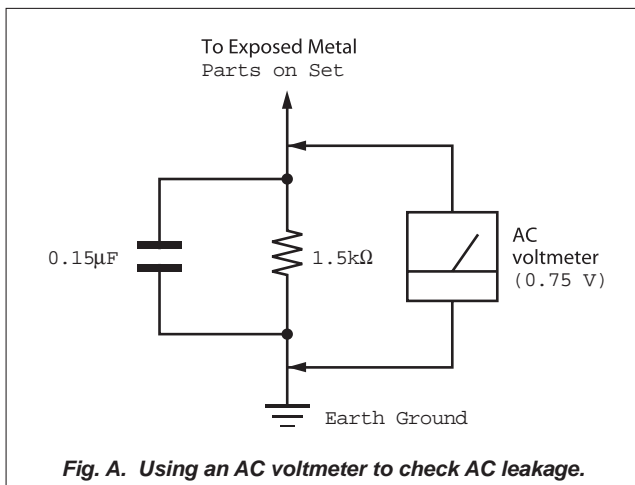

WARNING!!

WHEN SERVICING, DO NOT APPROACH THE LASER EXIT WITH THE EYE TOO CLOSELY. IN CASE IT IS NECESSARY TO CONFIRM LASER BEAM EMISSION, BE SURE TO OBSERVE FROM A DISTANCE OF MORE THAN 25 cm FROM THE SURFACE OF THE OBJECTIVE LENS ON THE OPTICAL PICK-UP BLOCK.

SAFETY-RELATED COMPONENT WARNING!!

COMPONENTS IDENTIFIED BY MARK \triangle OR DOTTED LINE WITH MARK \triangle ON THE SCHEMATIC DIAGRAMS AND IN THE PARTS LIST ARE CRITICAL TO SAFE OPERATION. REPLACE THESE COMPONENTS WITH SONY PARTS WHOSE PART NUMBERS APPEAR AS SHOWN IN THIS MANUAL OR IN SUPPLEMENTS PUBLISHED BY SONY.

ATTENTION AU COMPOSANT AYANT RAPPORT À LA SÉCURITÉ!

LES COMPOSANTS IDENTIFIÉS PAR UNE MARQUE \triangle SUR LES DIAGRAMMES SCHÉMATIQUES ET LA LISTE DES PIÈCES SONT CRITIQUES POUR LA SÉCURITÉ DE FONCTIONNEMENT. NE REMPLACER CES COMPOSANTS QUE PAR DES PIÈCES SONY DONT LES NUMÉROS SONT DONNÉS DANS CE MANUEL OU DANS LES SUPPLÉMENTS PUBLIÉS PAR SONY.

LEAKAGE TEST

The AC leakage from any exposed metal part to earth ground and from all exposed metal parts to any exposed metal part having a return to chassis, must not exceed 0.5 mA (500 microamperes). Leakage current can be measured by any one of three methods.

1. A commercial leakage tester, such as the Simpson 229 or RCA WT-540A. Follow the manufacturers' instructions to use these instruments.
2. A battery-operated AC milliammeter. The Data Precision 245 digital multimeter is suitable for this job.
3. Measuring the voltage drop across a resistor by means of a VOM or battery-operated AC voltmeter. The "limit" indication is 0.75V, so analog meters must have an accurate low-voltage scale. The Simpson 250 and Sanwa SH-63Trd are examples of a passive VOM that is suitable. Nearly all battery operated digital multimeters that have a 2V AC range are suitable (See Fig. A)

CAUTION:

The use of optical instrument with this product will increase eye hazard

CAUTION

Use of controls or adjustments or performance of procedures other than those specified herein may result in hazardous radiation exposure.



For customers in European countries

**CLASS 1 LASER PRODUCT
LASER KLASSE 1
LUOKAN 1 LASERLAITE
KLASS 1 LASERAPPARAT
1 类激光产品**

This appliance is classified as a CLASS 1 LASER product. The CLASS 1 LASER PRODUCT MARKING is located on the rear exterior.

This label is located on the laser protective housing inside the enclosure.

Unleaded solder

Boards requiring use of unleaded solder are printed with the lead-free mark (LF) indicating the solder contains no lead (Caution: Some printed circuit boards may not come printed with the lead free mark due to their particular size.)



LEAD FREE MARK

Unleaded solder has the following characteristics.

- Unleaded solder melts at a temperature about 40°C higher than ordinary solder.
Ordinary soldering irons can be used but the iron tip has to be applied to the solder joint for a slightly longer time.
Soldering irons using a temperature regulator should be set to about 350°C.
Caution: The printed pattern (copper foil) may peel away if the heated tip is applied for too long, so be careful!
- Strong viscosity
Unleaded solder is more viscous (sticky, less prone to flow) than ordinary solder so use caution not to let solder bridges occur such as on IC pins, etc.
- Usable with ordinary solder
It is best to use only unleaded solder but unleaded solder may also be added to ordinary solder.

TABLE OF CONTENTS

<u>Section</u>	<u>Title</u>	<u>Page</u>	<u>Section</u>	<u>Title</u>	<u>Page</u>
1.	SERVICE NOTE				
1-1.	Disc Removal Procedure If The Tray Cannot Be Ejected (Forced Ejection).....	1-1	4-12.	MB-139 Board (HDMI) Schematic Diagram (7/17).....	4-12
1-2.	Work when optical device are replaced.....	1-1	4-13.	MB-139 Board (ETHERNET) Schematic Diagram (8/17).....	4-13
1-3.	Test Disc.....	1-2	4-14.	MB-139 Board (AUDIO) Schematic Diagram (9/17).....	4-14
1-3-1.	Operation and Display.....	1-2	4-15.	MB-139 Board (VIDEO) Schematic Diagram (10/17).....	4-15
1-3-2.	Main functions.....	1-9	4-16.	MB-139 Board (GPIO/JTAG) Schematic Diagram (11/17).....	4-16
1-4.	Drive Repairing.....	1-15	4-17.	MB-139 Board (IF CON) Schematic Diagram (12/17).....	4-17
1-4-1.	Preparation.....	1-15	4-18.	MB-139 Board (FE OP/GIO) Schematic Diagram (13/17).....	4-18
1-4-2.	Checking Flow ~ Drive (BU) section ~	1-15	4-19.	MB-139 Board (FE_POWER/MOTOR DRIVE) Schematic Diagram (14/17)	4-19
1-4-3.	BU Check Flow [zz] ~	1-16	4-20.	MB-139 Board (DC FAN) Schematic Diagram (15/17).....	4-20
1-4-4.	BU (Optical Block) Repair Guide.....	1-16	4-21.	MB-139 Board (VIDEO IN OUT) Schematic Diagram (16/17).....	4-21
1-4-5.	BU Adjustment Flow [yy] ~	1-17	4-22.	MB-139 Board (SATA) Schematic Diagram (17/17)	4-22
1-4-6.	KEM-470AAA/C2RP Packing Spec.	1-17	4-23.	Waveforms	4-23E
1-4-7.	KEM-470AAA/C2RP Packing.....	1-18			
1-4-8.	BU Data Decode Jig.....	1-19	5.	PRINTED WIRING BOARD	
1-4-9.	Loading For Service	1-20	5-1.	This Note Is Common For Printed Wiring Boards	5-1
1-4-10.	Laser Caution Label.....	1-20	5-2.	FL-203 Board (REAR) Printed Wiring Board....	5-2
1-5.	Rear Panel Assembly Caution.....	1-23E	5-3.	IF-170 Board Printed Wiring Board	5-3
			5-4.	MB-139 Board(MAIN) Printed Wiring Board (Side A)	5-4
2.	DISASSEMBLY		5-5.	MB-139 Board (MAIN) Printed Wiring Board (Side B)	5-5E
2-1.	Disassembly Flow	2-1			
2-2.	Upper Case	2-1	6.	IC PIN FUNCTION DESCRIPTION.....	6-1
2-3.	Tray Cover Assy	2-2	7.	SERVICE MODE	7-1
2-4.	Front Panel Assy, FL-203 and IF-170 Board	2-2	8.	ERROR LOG LIST	8-1
2-5.	Rear Panel Block	2-3	9.	TROUBLESHOOTING.....	9-1
2-6.	MB-139 Board	2-3	10.	REPAIR PARTS LIST	
2-7.	BD Drive	2-4	10-1.	Exploded Views.....	10-1
2-8.	Switching Regulator.....	2-5E	10-1-1.	Case Section.....	10-1
2-9.	Circuit Boards Location	2-5E	10-1-2.	Main Chassis Section	10-2
3.	BLOCK DIAGRAM		10-1-3.	BD Section	10-3
3-1.	Overall Block Diagram.....	3-1	10-1-4.	Accessories	10-4
3-2.	DSP Block Diagram.....	3-2	10-2.	Electrical Parts List.....	10-5
3-3.	AV OUT Block Diagram.....	3-3			
3-4.	USB/ETHER, Block Diagram	3-4			
3-5.	Power Block Diagram	3-5E			
4.	SCHEMATIC DIAGRAM				
4-1.	This Note Is Common For Schematic Diagrams.....	4-1			
4-2.	Frame Schematic Diagram.....	4-2			
4-3.	IF-170 Board (FRONT RIGHT) Schematic Diagram ...	4-3			
4-4.	IF-170 Board (USB FRONT) Schematic Diagram	4-4			
4-5.	FL-203 Board (POWER) Schematic Diagram ...	4-5			
4-6.	MB-139 Board (DDR 3 A) Schematic Diagram (1/17).....	4-6			
4-7.	MB-139 Board (DDR 3 B) Schematic Diagram.....	4-7			
4-8.	MB-139 Board (POWER) Schematic Diagram (3/17).....	4-8			
4-9.	MB-139 Board (POWER 2) Schematic Diagram (4/17).....	4-9			
4-10.	MB-139 Board (FLASH/HOST) Schematic Diagram (5/17).....	4-10			
4-11.	MB-139 Board (USB) Schematic Diagram (6/17).....	4-11			

SECTION 1 SERVICE NOTE

1-1. DISC REMOVAL PROCEDURE IF THE TRAY CANNOT BE EJECTED (FORCED EJECTION)

1. Remove the upper case. (Refer to page 2-1)
2. Insert a clip in the hole of a drive and open a tray.

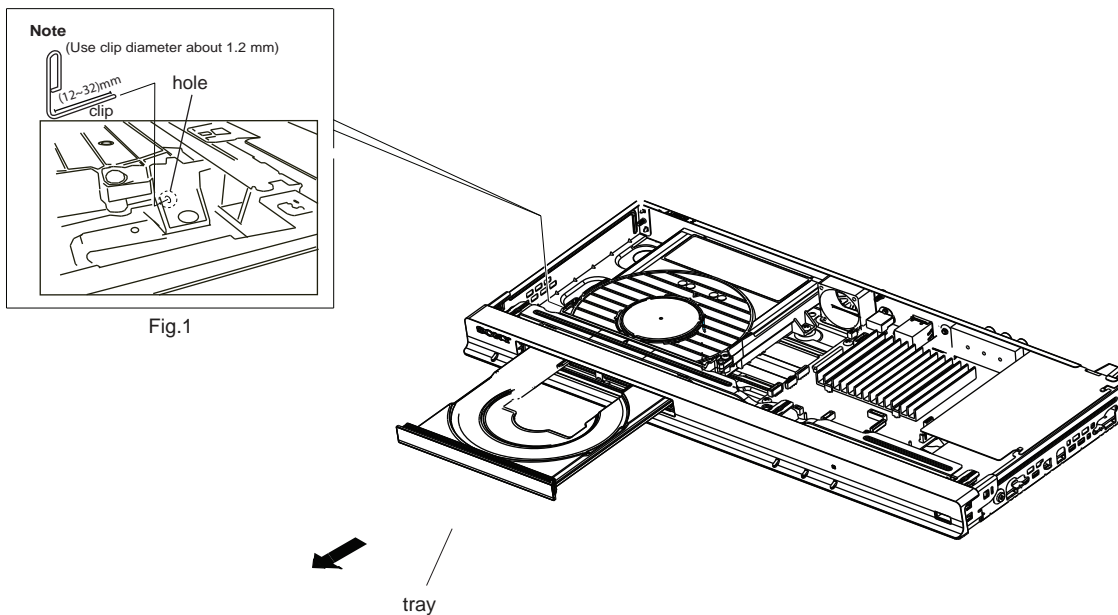

1-2. Work when optical device are replaced

Note: Please do the following work when you replace the optical device.

1. Install it in PC after downloading two set of software from following URL.
(Refer to “1-4-8. BU Data Decode Jig” on page 1-19)

STEP 1

Microsoft .NET Framework Version 2.0 Redistributable Package (x86)

<http://www.microsoft.com/downloads/details.aspx?displaylang=en&FamilyID=0856eacb-4362-4b0d-8edd-aab15c5e04f5>

STEP 2

Microsoft .NET Framework 2.0 Service Pack 1 (x86)

<http://www.microsoft.com/downloads/details.aspx?displaylang=en&FamilyID=79bc3b77-e02c-4ad3-aacf-a7633f706ba5>

2. Take a photograph of the bar code on the optical device. The valid bar code photo as shown in Fig.2

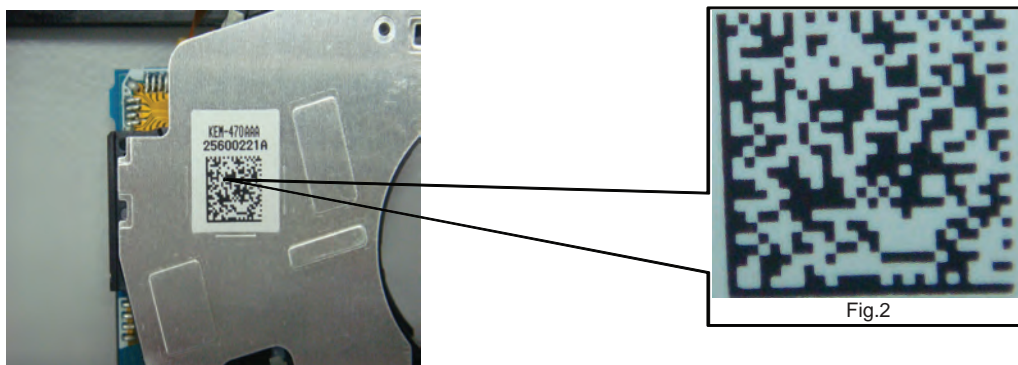

3. Drag-and-drop the bar code photograph to the icon of decode software (BDPRdec).
 - * The decode software is a complete set of “BDPRdec”, “Tasman.Bars.dll”, and “SavePath”.
 - * Because decode software cannot be attached, it separately distributes it.
4. Input the password when you start decode software.
 - * Inquire of each service headquarters because the password cannot be disclosed.
5. Write the decode data to the set.
(Refer to “1-4-4. BU (Optical Block) Repair Guide” on page 1-16 and “1-4-5. BU Adjustment Flow [yy]” on page 1-17)

1-3. TEST DISC

Part No.	Description	Layer
J-6090-199-A	BLX-104	Single Layer
J-6090-200-A	BLX-204	Dual Layer
J-2501-307-A	CD (HLX-A1)	
J-2501-305-A	HLX-513	Single Layer (NTSC)
J-2501-306-A	HLX-514	Dual Layer (NTSC)
J-6090-077-A	HLX-506	Single Layer (PAL)
J-6090-078-A	HLX-507	Dual Layer (PAL)

1-3-1. Operation and Display

Check Items

- 1) BLX-104
 1. Select 23.976Hz/1080p
 2. Play "4.Motion pictures"
 3. Check whether player can play back or not
 4. Check each outputs
 - Video:
 - Composite/component/HDMI
 - Audio:
 - Digital out (Coaxial/Optical)/Audio out/5.1Ch output

* When 1080/24p monitor is nothing, 1080i (59.94Hz or 50Hz) can use instead of 1080/24p. However this is temporary correspondence.
- 2) BLX-204
 1. Select 1080i (59.94Hz or 50Hz)
 2. Play "4.Motion pictures"
 3. Check whether player can play back or not
(Check the picture and sound output)
- 3) CD (HLX-A1)

Check whether player can play back or not
(Check the sound output)
- 4) HLX-513/514 (NTSC), HLX-506/507 (PAL)
 1. After displayed Main Menu, select "1.Video"
 2. Play "1.Color Bar 100%"
(Check the picture and sound output)
 3. Return to Menu
 4. Play "Demonstration 4:3" or "5.Demonstration 16:9"
(Check the picture and sound output)

1-3-1-1. BLX-104 Menu Function (1)

Main Menu

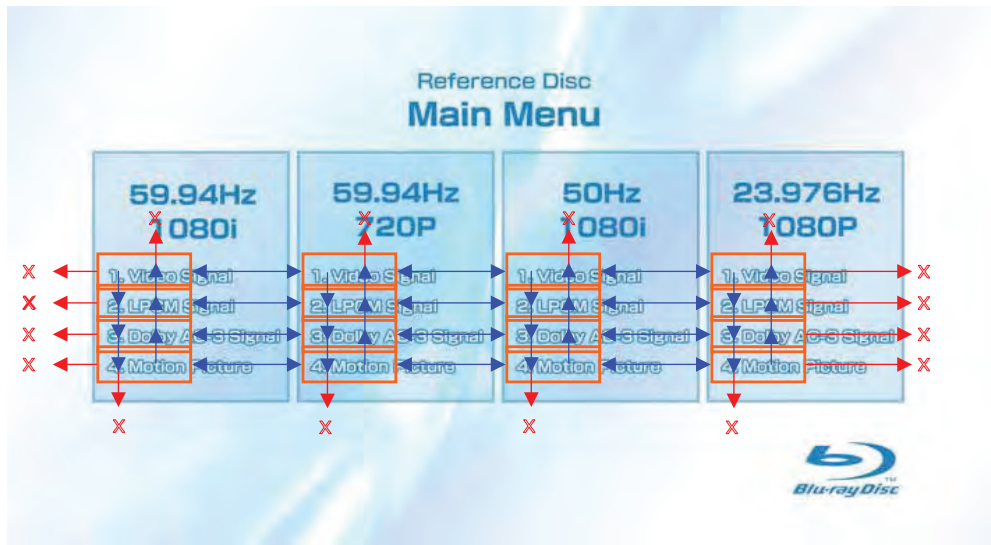

1) When the disc is inserted, 1. Video Signal of 59.94Hz/1080i of the Main Menu is selectively displayed.

1-3-1-2. BLX-104 Menu Function (2)

Main Menu

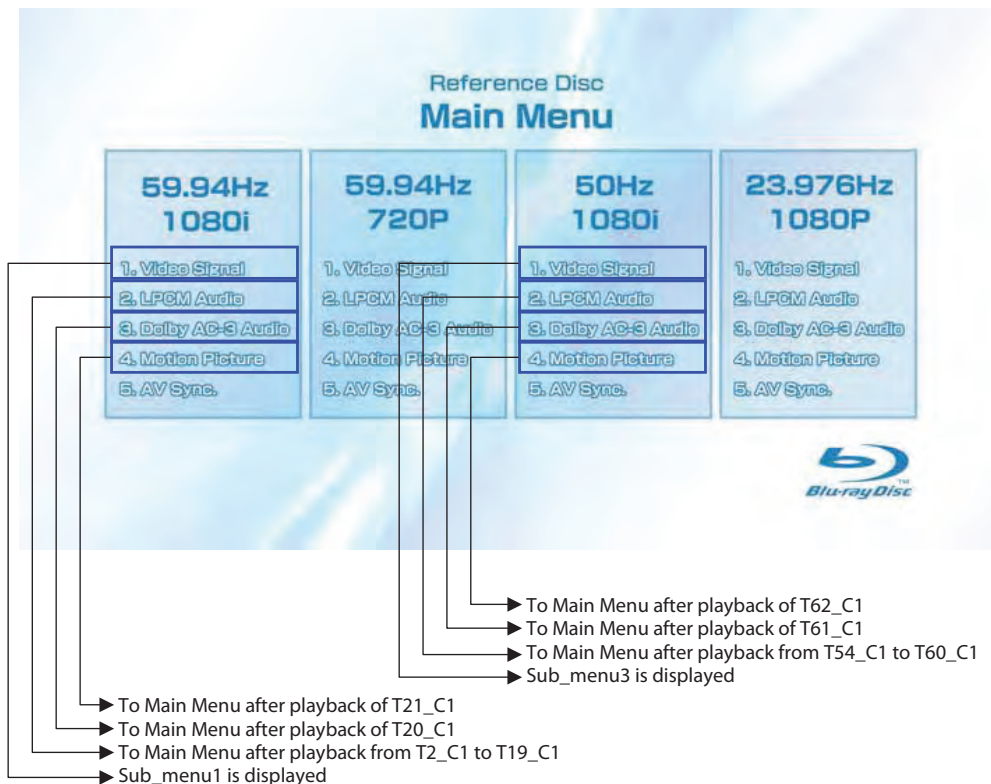

* When returning to Main Menu after playback from each button of 59.94Hz/1080i, 1. Video Signal of 59.94Hz/1080i is selectively displayed.

* When returning to Main Menu after playback from each button of 50Hz/1080i, 1. Video Signal of 50Hz/1080i is selectively displayed.

* 5. AV Sync does not operate.

Note:



1-3-1-3. BLX-104 Menu Function (3)

Main Menu

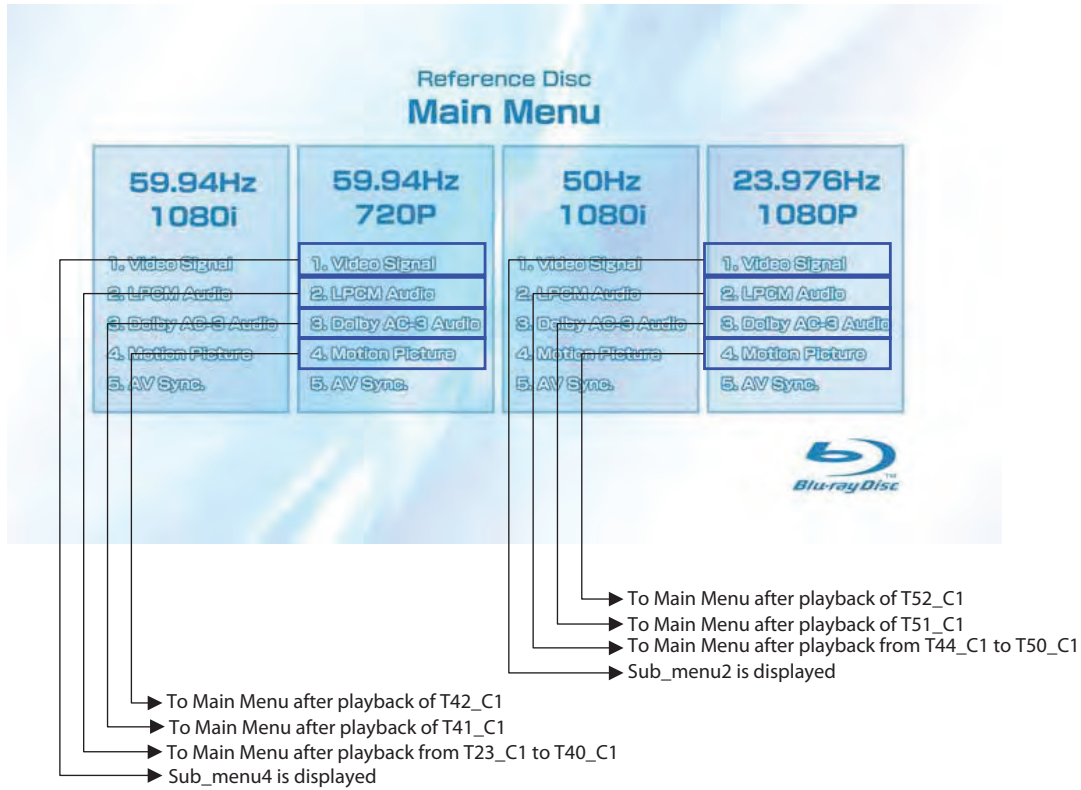

- * When returning to Main Menu after playback from each button of 59.94Hz/720P, 1. Video Signal of 59.94Hz/720P is selectively displayed.
- * When returning to Main Menu after playback from each button of 23.976Hz/1080P, 1. Video Signal of 23.976Hz/1080P is selectively displayed.
- * 5. AV Sync does not operate.

1-3-1-4. BLX-104 Menu Function (4) Sub menu1

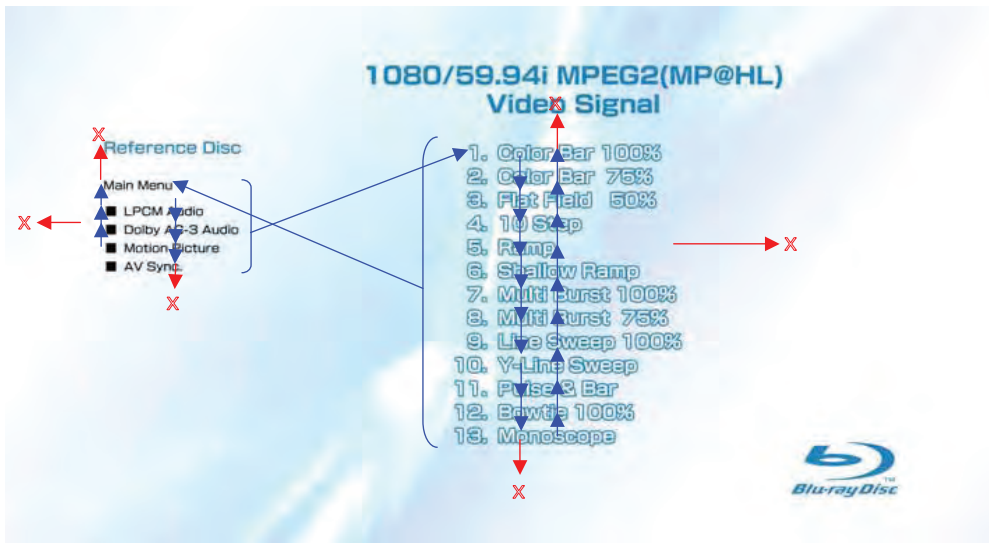

- 1) At the display of Sub menu1, 1. Color Bar 100% is selectively displayed.
- 2) Selection of 1. Color Bar 100% t Return to Sub menu1 after seamless playback from T1_C1 to T1_C13. 1. Color Bar 100% is selectively displayed on Sub menu1 screen.
- 3) Selection of 2. Color Bar 75% t Return to Sub menu1 after seamless playback from T1_C2 to T1_C13. 1. Color Bar 100% is selectively displayed on Sub menu1 screen.
- 4) At the selection of 3 - 13, item 3 mentioned above is executed as the routine.
- 5) At the display of Sub menu1, Main Menu is selected t Jump to Main Menu. At the display of Main Menu, 1. Video Signal of 59.94Hz/1080i is selectively displayed.
- 6) Selection of LPCM Audio t Playback from T2_C1 to T19_C1. SubPic that corresponds to Audio stream 1 is forcibly displayed. During the playback, when audio channel changes, the caption that corresponds to each audio stream is forcibly displayed. Return to Sub menu1 after playback. 1. Color Bar 100% is selectively displayed on Sub menu1 screen.
- 7) Selection of Dolby AC-3 Audio t Playback of T20_C1. SubPic that corresponds to Audio stream 1 is forcibly displayed. During the playback, when audio channel changes, the caption that corresponds to each audio stream is forcibly displayed. Return to Sub menu1 after playback. 1. Color Bar 100% is selectively displayed on Sub menu1 screen.
- 8) Selection of Motion Picture t Return to Sub menu1 after playback of T21_C1. 1. ColorBar 100% is selectively displayed on Sub menu1 screen.
- 9) At the selection of Main Menu, 1. VideoSignal of 1080/59.94i of Main Menu is selectively displayed.
- 10) AV Sync does not operate.

1-3-1-5. BLX-104 Menu Function (5) Sub menu2

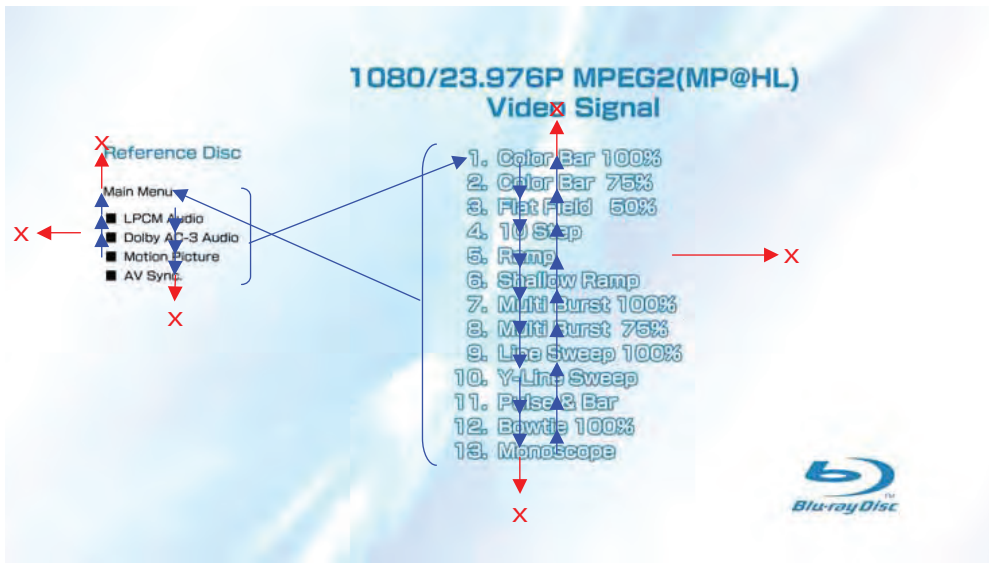

- 1) At the display of Sub menu2, 1. Color Bar 100% is selectively displayed.
- 2) Selection of 1. Color Bar 100% t Return to Sub menu2 after seamless playback from T43_C1 to T43_C13. 1. Color Bar 100% is selectively displayed on Sub menu2 screen.
- 3) Selection of 2. Color Bar 75% t Return to Sub menu2 after seamless playback from T43_C2 to T43_C13. 1. Color Bar 100% is selectively displayed on Sub menu2 screen.
- 4) At the selection of 3 - 13, item 3 mentioned above is executed as the routine.
- 5) At the display of Sub menu2, Main Menu is selected t Jump to Main Menu. At the display of Main Menu, 1. Video Signal of 23.976Hz/1080P is selectively displayed.
- 6) Selection of LPCM Audio t Playback from T44_C1 to T50_C1. SubPic that corresponds to Audio stream 1 is forcibly displayed. During the playback, when audio channel changes, the caption that corresponds to each audio stream is forcibly displayed. Return to Sub menu2 after playback. 1. Color Bar 100% is selectively displayed on Sub menu2 screen.
- 7) Selection of Dolby AC-3 Audio t Playback of T51_C1. SubPic that corresponds to Audio stream 1 is forcibly displayed. During the playback, when audio channel changes, the caption that corresponds to each audio stream is forcibly displayed. Return to Sub menu2 after playback. 1. Color Bar 100% is selectively displayed on Sub menu2 screen.
- 8) Selection of Motion Picture t Return to Sub menu2 after playback of T52_C1. 1. Color Bar 100% is selectively displayed on Sub menu2 screen.
- 9) At the selection of Main Menu, 1. Video Signal of 1080/23.976P of Main Menu is selectively displayed.
- 10) AV Sync does not operate.

1-3-1-6. BLX-104 Menu Function (6)

Sub menu3

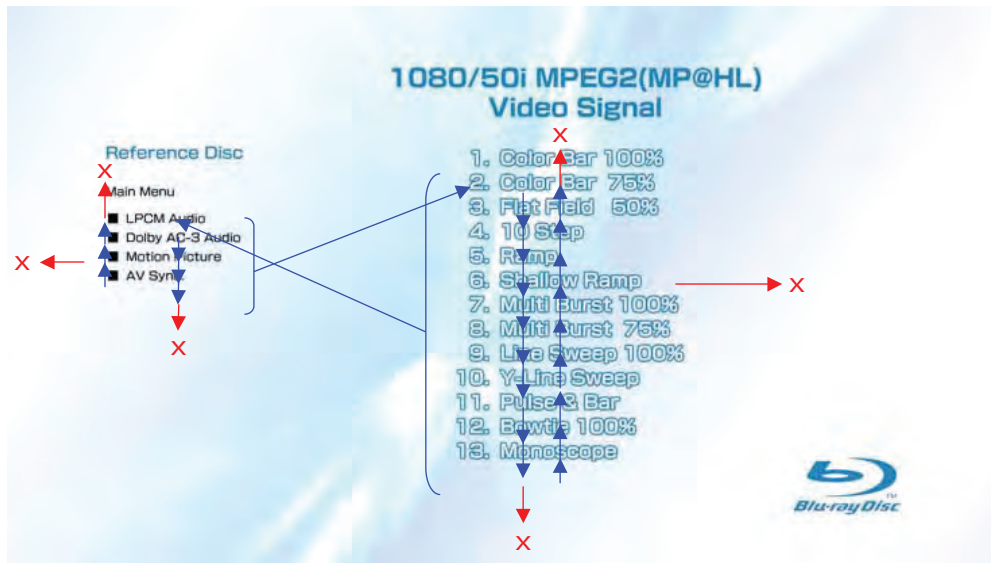

- 1) At the display of Sub menu3, 1. Color Bar 100% is selectively displayed.
- 2) Selection of 1. Color Bar 100% t Return to Sub menu3 after seamless playback from T53_C1 to T53_C13. 1. Color Bar 100% is selectively displayed on Sub menu3 screen.
- 3) Selection of 2. Color Bar 75% t Return to Sub menu3 after seamless playback from T53_C2 to T53_C13. 1. Color Bar 100% is selectively displayed on Sub menu3 screen.
- 4) At the selection of 3 - 13, item 3 mentioned above is executed as the routine.
- 5) At the display of Sub menu3, Main Menu is selected t Jump to Main Menu. At the display of Main Menu, 1. Video Signal of 50Hz/1080i is selectively displayed.
- 6) Selection of LPCM Audio t Playback from T54_C1 to T60_C1. SubPic that corresponds to Audio stream 1 is forcibly displayed. During the playback, when audio channel changes, the caption that corresponds to each audio stream is forcibly displayed. Return to Sub menu3 after playback. 1. Color Bar 100% is selectively displayed on Sub menu3 screen.
- 7) Selection of Dolby AC-3 Audio t Playback of T61_C1. SubPic that corresponds to Audio stream 1 is forcibly displayed. During the playback, when audio channel changes, the caption that corresponds to each audio stream is forcibly displayed. Return to Sub menu3 after playback. 1. Color Bar 100% is selectively displayed on Sub menu3 screen.
- 8) Selection of Motion Picture t Return to Sub menu3 after playback of T62_C1. 1. Color Bar 100% is selectively displayed on Sub menu3 screen.
- 9) At the selection of Main Menu, 1. Video Signal of 1080/50i of Main Menu is selectively displayed.
- 10) AV Sync does not operate.

1-3-1-7. BLX-104 Menu Function (7)

Sub menu4

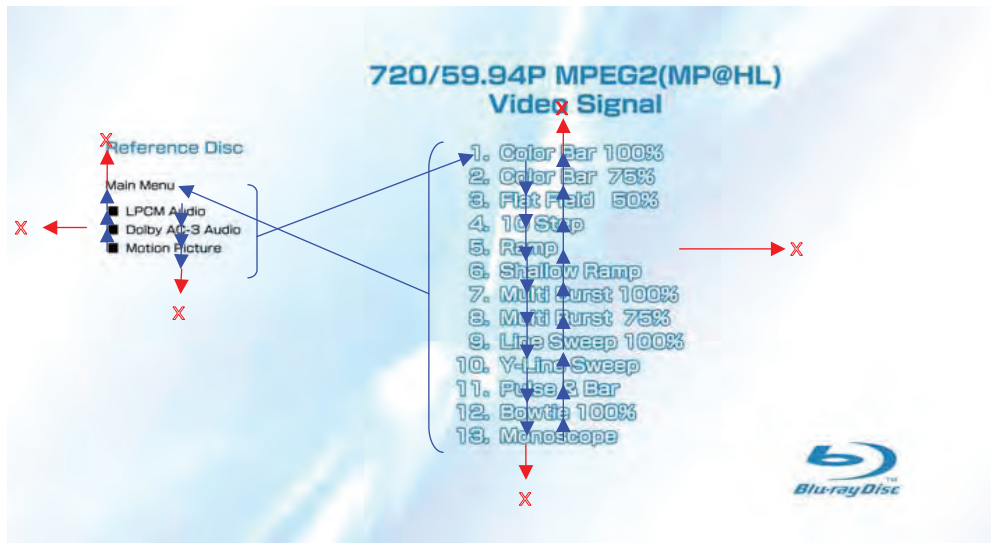

- 1) At the display of Sub menu4, 1. Color Bar 100% is selectively displayed.
- 2) Selection of 1. Color Bar 100% t Return to Sub menu4 after seamless playback from T22_C1 to T22_C13. 1. Color Bar 100% is selectively displayed on Sub menu4 screen.
- 3) Selection of 2. Color Bar 75% t Return to Sub menu4 after seamless playback from T22_C2 to T22_C13. 1. Color Bar 100% is selectively displayed on Sub menu4 screen.
- 4) At the selection of 3 - 13, item 3 mentioned above is executed as the routine.
- 5) At the display of Sub menu4, Main Menu is selected t Jump to Main Menu. At the display of Main Menu, 1. Video Signal of 59.94Hz/720P is selectively displayed.
- 6) Selection of LPCM Audio t Playback from T44_C1 to T50_C1. SubPic that corresponds to Audio stream 1 is forcibly displayed. During the playback, when audio channel changes, the caption that corresponds to each audio stream is forcibly displayed. Return to Sub menu4 after playback. 1. Color Bar 100% is selectively displayed on Sub menu4 screen.
- 7) Selection of Dolby AC-3 Audio t Playback of T51_C1. SubPic that corresponds to Audio stream 1 is forcibly displayed. During the playback, when audio channel changes, the caption that corresponds to each audio stream is forcibly displayed. Return to Sub menu4 after playback. 1. Color Bar 100% is selectively displayed on Sub menu4 screen.
- 8) Selection of Motion Picture t Return to Sub menu4 after playback of T52_C1. 1. Color Bar 100% is selectively displayed on Sub menu4 screen.
- 9) At the selection of Main Menu, 1. Video Signal of 720/59.94P of Main Menu is selectively displayed.
- 10) AV Sync does not operate.

1-3-2 Menu Function

1-3-2-1. BLX-204 Menu Function (1)

Main Menu

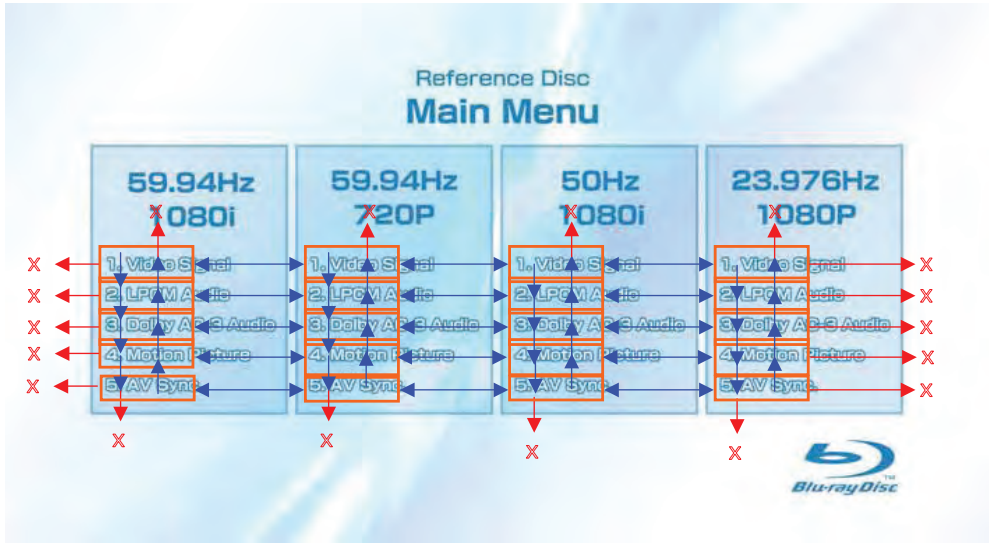

1) When the disc is inserted, 1. Video Signal of 59.94Hz/1080i of the Main Menu is selectively displayed.

1-3-2-2. BLX-204 Menu Function (2)

Main Menu

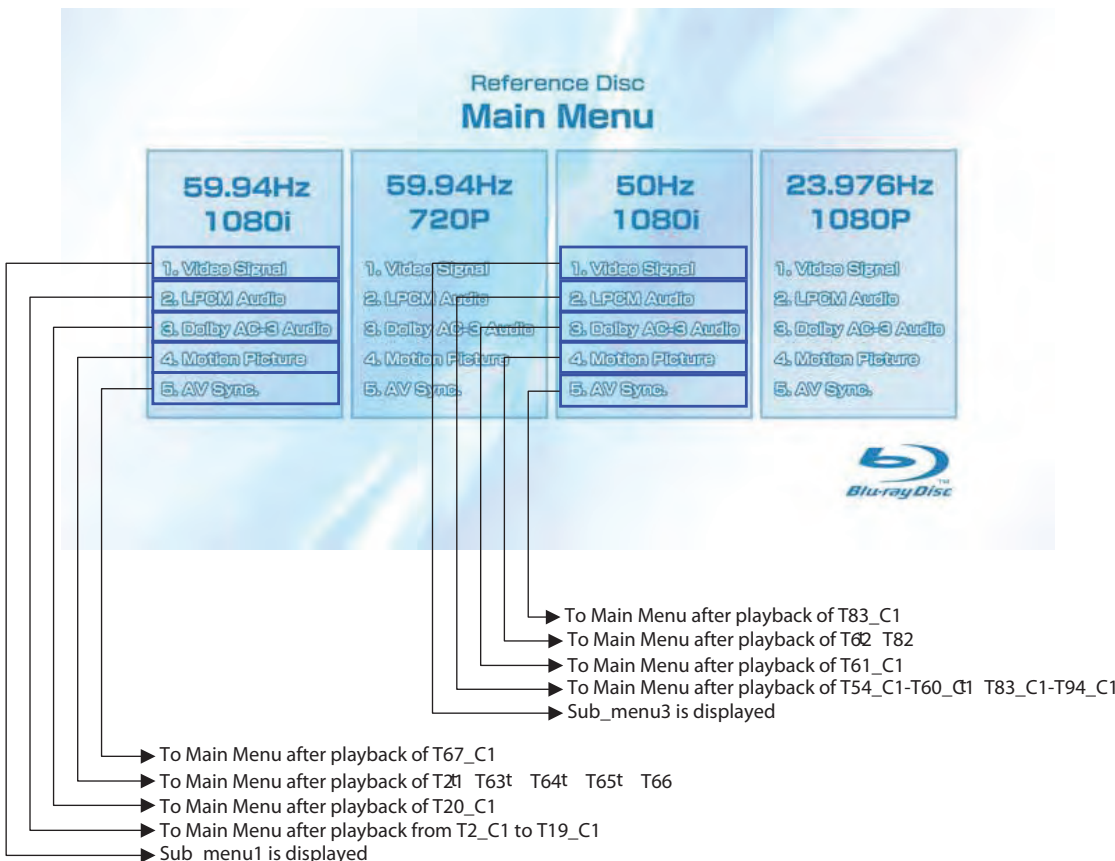

* When returning to Main Menu after playback from each button of 59.94Hz/1080i, 1. Video Signal of 59.94Hz/1080i is selectively displayed.

* When returning to Main Menu after playback from each button of 50Hz/1080i, 1. Video Signal of 50Hz/1080i is selectively displayed.

Note:



1-3-2-3. BLX-204 Menu Function (3)
Main Menu

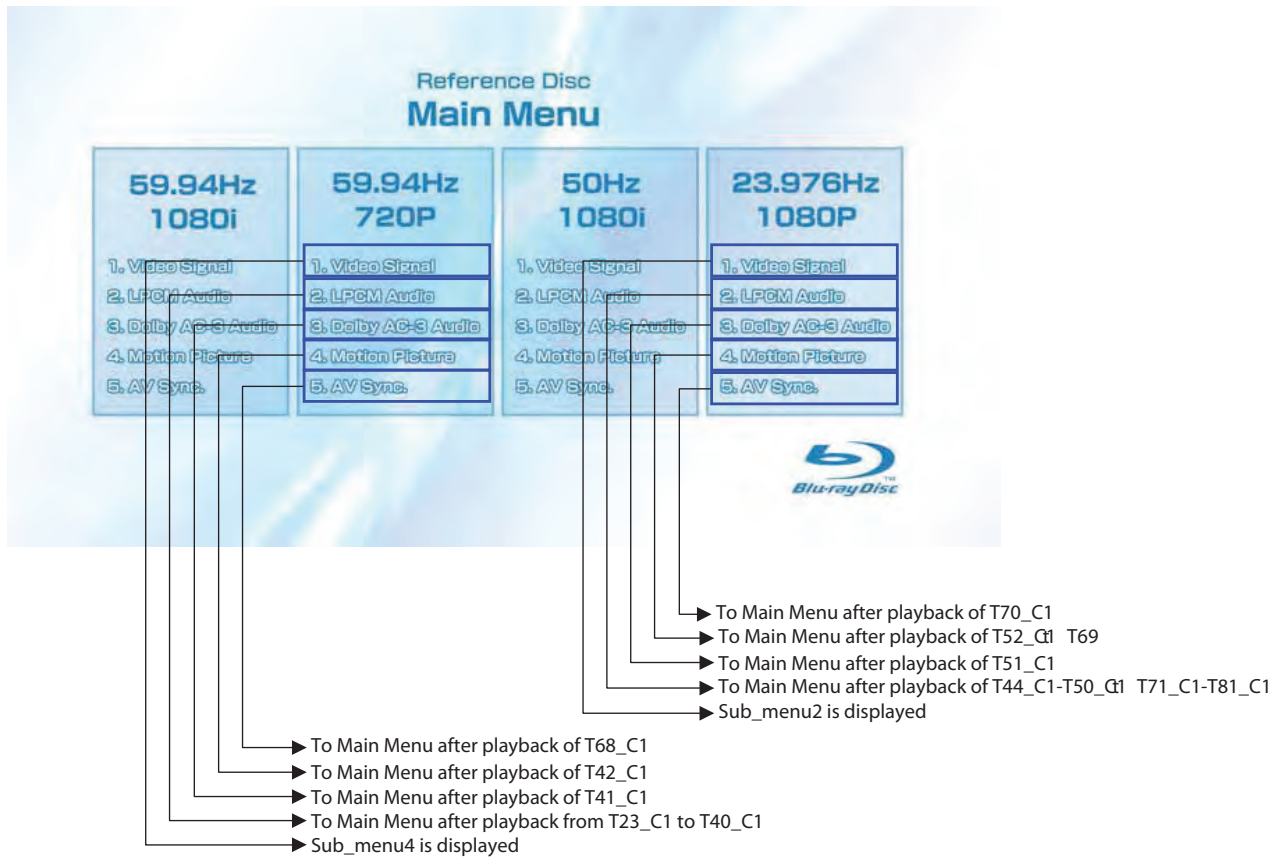

- * When returning to Main Menu after playback from each button of 59.94Hz/720P, 1. Video Signal of 59.94Hz/720P is selectively displayed.
- * When returning to Main Menu after playback from each button of 23.976Hz/1080P, 1. Video Signal of 23.976Hz/1080P is selectively displayed.

1-3-2-4. BLX-204 Menu Function (4)

Sub menu 1

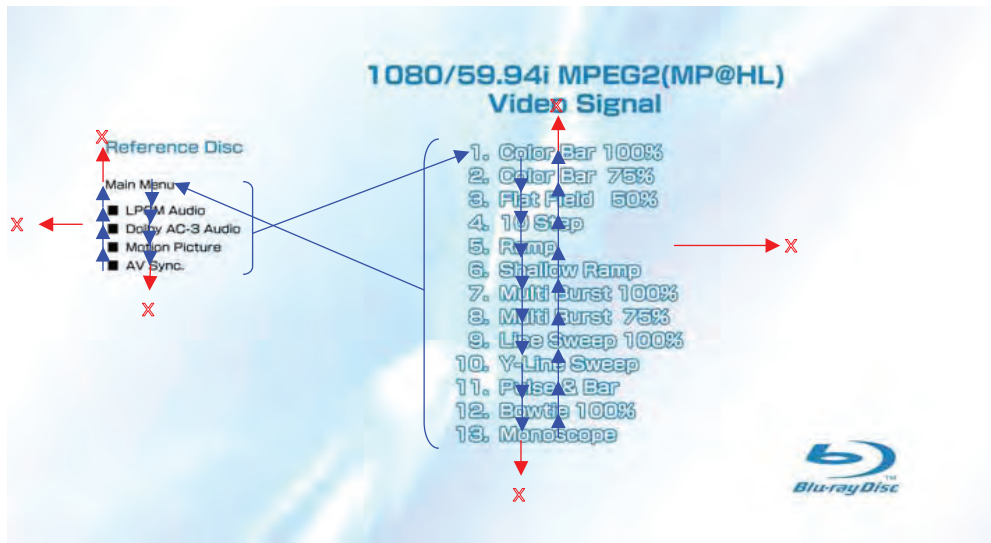

- 1) At the display of Sub menu1, 1. Color Bar 100% is selectively displayed.
- 2) Selection of 1. Color Bar 100% t Return to Sub menu1 after seamless playback from T1_C1 to T1_C13. 1. Color Bar 100% is selectively displayed on Sub menu1 screen.
- 3) Selection of 2. Color Bar 75% t Return to Sub menu1 after seamless playback from T1_C2 to T1_C13. 1. Color Bar 100% is selectively displayed on Sub menu1 screen.
- 4) At the selection of 3 - 13, item 3 mentioned above is executed as the routine.
- 5) At the display of Sub menu1, Main Menu is selected t Jump to Main Menu. At the display of Main Menu, 1. Video Signal of 59.94Hz/1080i is selectively displayed.
- 6) Selection of LPCM Audio t Playback from T2_C1 to T19_C1. SubPic that corresponds to Audio stream 1 is forcibly displayed. During the playback, when audio channel changes, the caption that corresponds to each audio stream is forcibly displayed. Return to Sub menu1 after playback. 1. Color Bar 100% is selectively displayed on Sub menu1 screen.
- 7) Selection of Dolby AC-3 Audio t Playback of T20_C1. SubPic that corresponds to Audio stream 1 is forcibly displayed. During the playback, when audio channel changes, the caption that corresponds to each audio stream is forcibly displayed. Return to Sub menu1 after playback. 1. Color Bar 100% is selectively displayed on Sub menu1 screen.
- 8) Selection of Motion Picture t Return to Sub menu1 after playback of T21_C1. 1. Color Bar 100% is selectively displayed on Sub menu1 screen.
- 9) Selection of AV Sync t Return to Sub menu1 after playback of T67_C1. 1. Color Bar 100% is selectively displayed on Sub menu1 screen.
- 10) At the selection of Main Menu, 1. Video Signal of 1080/59.94i of Main Menu is selectively displayed.

1-3-2-5. BLX-204 Menu Function (5)

Sub menu 2

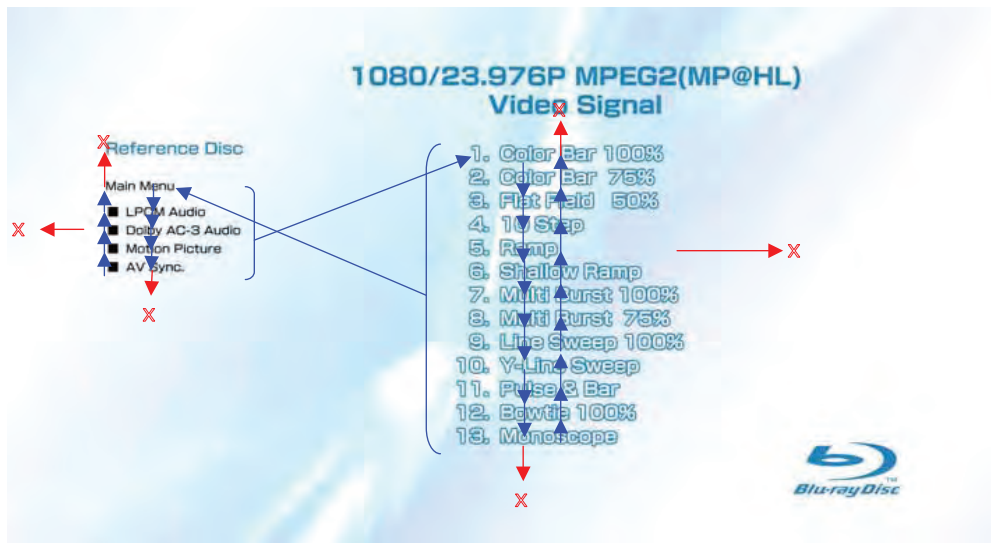

- 1) At the display of Sub menu2, 1. Color Bar 100% is selectively displayed.
- 2) Selection of 1. Color Bar 100% t Return to Sub menu2 after seamless playback from T43_C1 to T43_C13. 1. Color Bar 100% is selectively displayed on Sub menu2 screen.
- 3) Selection of 2. Color Bar 75% t Return to Sub menu2 after seamless playback from T43_C2 to T43_C13. 1. Color Bar 100% is selectively displayed on Sub menu2 screen.
- 4) At the selection of 3 - 13, item 3 mentioned above is executed as the routine.
- 5) At the display of Sub menu2, Main Menu is selected t Jump to Main Menu. At the display of Main Menu, 1. Video Signal of 23.976Hz/1080P is selectively displayed.
- 6) Selection of LPCM Audio t Playback from T44_C1 to T50_C1 and from T71_C1 to T81_C1. SubPic that corresponds to Audio stream 1 is forcibly displayed.
During the playback, when audio channel changes, the caption that corresponds to each audio stream is forcibly displayed. Return to Sub menu2 after playback. 1. Color Bar 100% is selectively displayed on Sub menu2 screen.
- 7) Selection of Dolby AC-3 Audio t Playback of T51_C1. SubPic that corresponds to Audio stream 1 is forcibly displayed.
During the playback, when audio channel changes, the caption that corresponds to each audio stream is forcibly displayed. Return to Sub menu2 after playback. 1. Color Bar 100% is selectively displayed on Sub menu2 screen.
- 8) Selection of Motion Picture t Return to Sub menu2 after playback of T52_C1 and T69. 1. Color Bar 100% is selectively displayed on Sub menu2 screen.
- 9) Selection of AV Sync t Return to Sub menu2 after playback of T70_C1. 1. Color Bar 100% is selectively displayed on Sub menu2 screen.
- 10) At the selection of Main Menu, 1. Video Signal of 1080/23.976P of Main Menu is selectively displayed.

1-3-2-6. BLX-204 Menu Function (6)

Sub menu 3

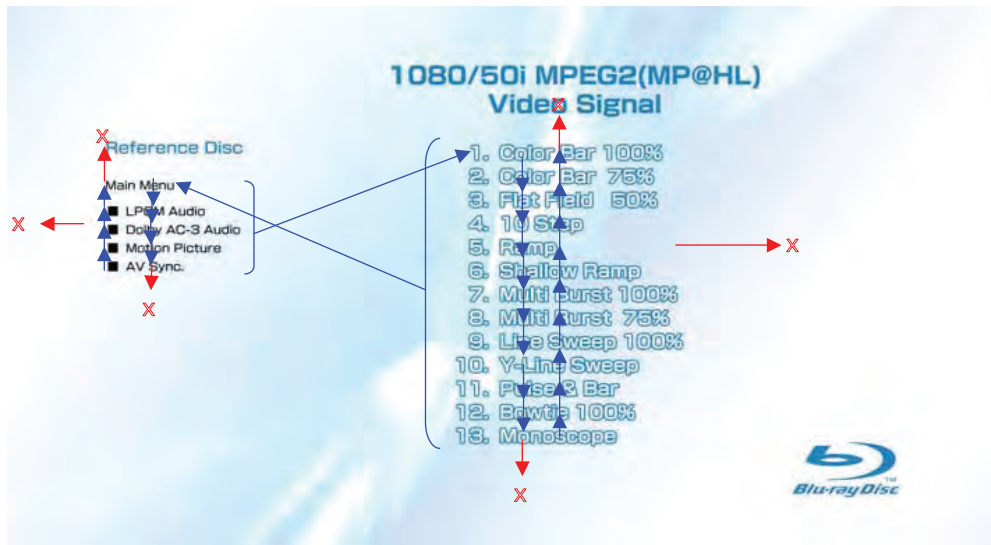

- 1) At the display of Sub menu3, 1. Color Bar 100% is selectively displayed.
- 2) Selection of 1. Color Bar 100% t Return to Sub menu3 after seamless playback from T53_C1 to T53_C13. 1. Color Bar 100% is selectively displayed on Sub menu3 screen.
- 3) Selection of 2. Color Bar 75% t Return to Sub menu3 after seamless playback from T53_C2 to T53_C13. 1. Color Bar 100% is selectively displayed on Sub menu3 screen.
- 4) At the selection of 3 - 13, item 3 mentioned above is executed as the routine.
- 5) At the display of Sub menu3, Main Menu is selected t Jump to Main Menu. At the display of Main Menu, 1. Video Signal of 50Hz/1080i is selectively displayed.
- 6) Selection of LPCM Audio t Playback from T54_C1 to T60_C1 and from T84_C1 to T94_C1. SubPic that corresponds to Audio stream 1 is forcibly displayed.
During the playback, when audio channel changes, the caption that corresponds to each audio stream is forcibly displayed. Return to Sub menu3 after playback. 1. Color Bar 100% is selectively displayed on Sub menu3 screen.
- 7) Selection of Dolby AC-3 Audio t Playback of T61_C1. SubPic that corresponds to Audio stream 1 is forcibly displayed.
During the playback, when audio channel changes, the caption that corresponds to each audio stream is forcibly displayed. Return to Sub menu3 after playback. 1. Color Bar 100% is selectively displayed on Sub menu3 screen.
- 8) Selection of Motion Picture t Return to Sub menu3 after playback of T62_C1 and T82. 1. Color Bar 100% is selectively displayed on Sub menu3 screen.
- 9) Selection of AV Sync t Return to Sub menu3 after playback of T83_C1. 1. Color Bar 100% is selectively displayed on Sub menu3 screen.
- 10) At the selection of Main Menu, 1. Video Signal of 1080/50i of Main Menu is selectively displayed.

1-3-2-7. BLX-204 Menu Function (7)

Sub menu 4

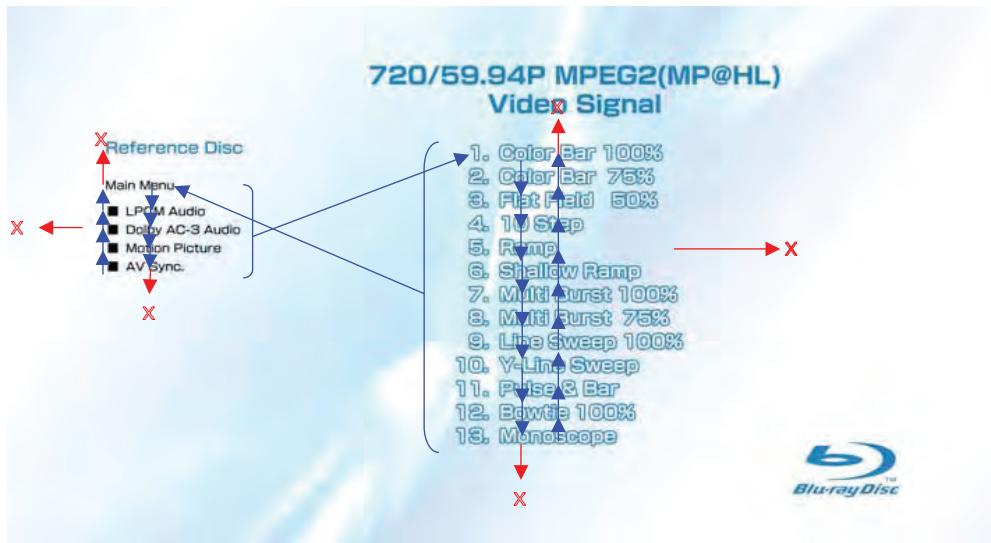

- 1) At the display of Sub menu4, 1. Color Bar 100% is selectively displayed.
- 2) Selection of 1. Color Bar 100% t Return to Sub menu4 after seamless playback from T22_C1 to T22_C13. 1. Color Bar 100% is selectively displayed on Sub menu4 screen.
- 3) Selection of 2. Color Bar 75% t Return to Sub menu4 after seamless playback from T22_C2 to T22_C13. 1. Color Bar 100% is selectively displayed on Sub menu4 screen.
- 4) At the selection of 3 - 13, item 3 mentioned above is executed as the routine.
- 5) At the display of Sub menu4, Main Menu is selected t Jump to Main Menu. At the display of Main Menu, 1. Video Signal of 59.94Hz/720P is selectively displayed.
- 6) Selection of LPCM Audio t Playback from T44_C1 to T50_C1. SubPic that corresponds to Audio stream 1 is forcibly displayed. During the playback, when audio channel changes, the caption that corresponds to each audio stream is forcibly displayed. Return to Sub menu4 after playback. 1. Color Bar 100% is selectively displayed on Sub menu4 screen.
- 7) Selection of Dolby AC-3 Audio t Playback of T51_C1. SubPic that corresponds to Audio stream 1 is forcibly displayed. During the playback, when audio channel changes, the caption that corresponds to each audio stream is forcibly displayed. Return to Sub menu4 after playback. 1. Color Bar 100% is selectively displayed on Sub menu4 screen.
- 8) Selection of Motion Picture t Return to Sub menu4 after playback of T52_C1. 1. Color Bar 100% is selectively displayed on Sub menu4 screen.
- 9) Selection of AV Sync t Return to Sub menu4 after playback of T68_C1. 1. Color Bar 100% is selectively displayed on Sub menu4 screen.
- 10) At the selection of Main Menu, 1. Video Signal of 720/59.94P of Main Menu is selectively displayed.

1-4. DRIVE REPAIRING

1-4-1. Preparation

- **ESD Measures**

It is necessary to check the working space ESD condition before starting the Drive Part (BU) repairs

The ESD-resistance of BD Laser is weaker than DVD/CD Laser
To prevent ESD destruction, please make sure the working space and human ESD.

- How to open FFC Holder. Refer below picture.

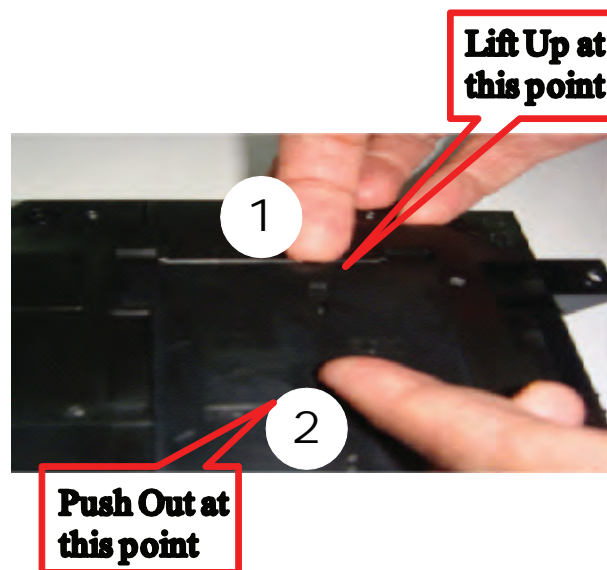

1-4-2. Checking Flow ~ Drive (BU) section ~

Drive flowchart

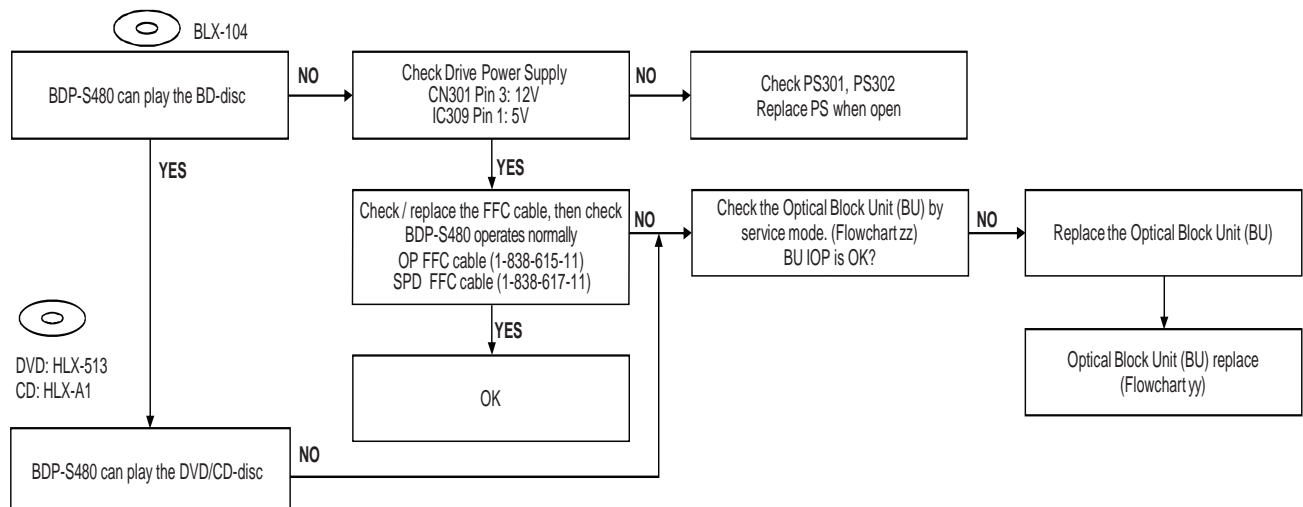

1-4-3. BU Check Flow [zz] ~

Before BU Replacement

Optical Block Unit (BU) IOP check flow (zz) ~ [Before BU Replacement]

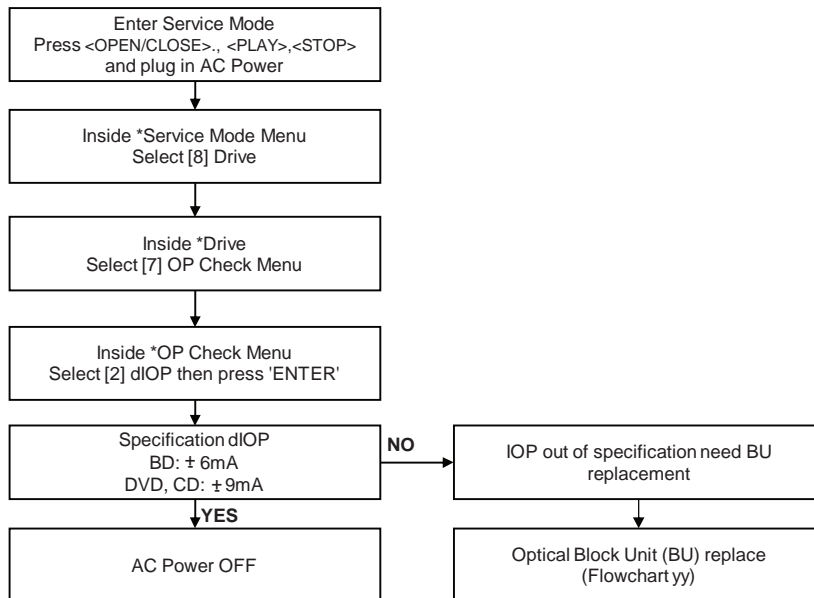

1-4-4. BU (Optical Block) Repair Guide

BDP 6G (BDP-S480) series component structure is as same as conventional DVD Players. However BD player requires precise read out functions and also secure contents Protection system.

Since above requirement, it is necessary to set/adjust BU data to EEPROM.

The following cases need Adjustments;

- (1) Replace BU (MB is original)
- (2) Replace MB (BU is original)
- (3) Replace both BU and MB

•JIG Requirement

- Digital camera (recommend with macro mode)
- Barcode decoder (BDPRdec_ver2.0) installed in JIG PC's
- USB memory
- ESD work bench

•Procedure (all cases) → Refer the diagram

Remarks:

The servo adjustment procedure will be carried out during OP data Writing.
There is no manual adjustment procedure. LD ON TIME history doesn't carry over.
Do not touch any optical block parts, Turn Table and during replacing. BD Laser diode is very sensitive!

1-4-5. BU Adjustment Flow [yy] ~

Optical Block Unit (BU) OP Data Write Flow (yy) ~ [After BU/MB Replacement]

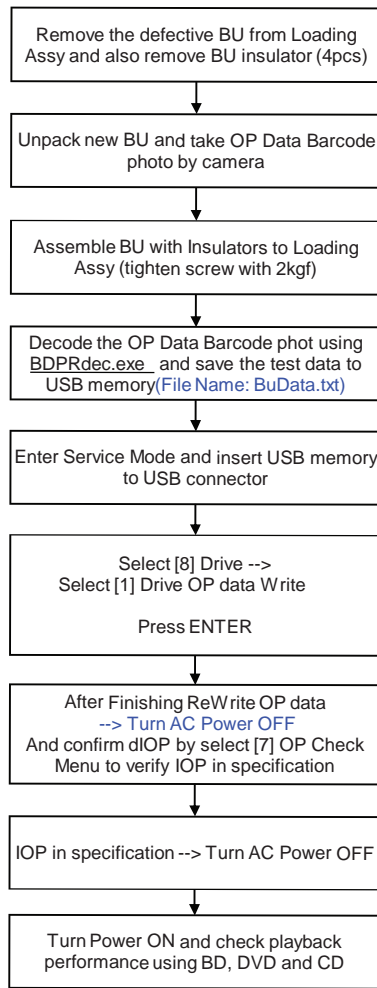

The following cases need OP Data Write:
 (1) Replace BU (MB is original)
 (2) Replace MB (BU is original)
 (3) Replace both BU and MB

JIG requirement
 Digital camera (with macro mode)
 Barcode decoder (BDPRdec.exe) installed in jig
 PC's (jig purpose)
 USB memory
 ESD free work bench

BLX-104
 DVD: HLX-513
 CD: HLX-A1

1-4-6. KEM-470AAA/C2RP Packing Spec.

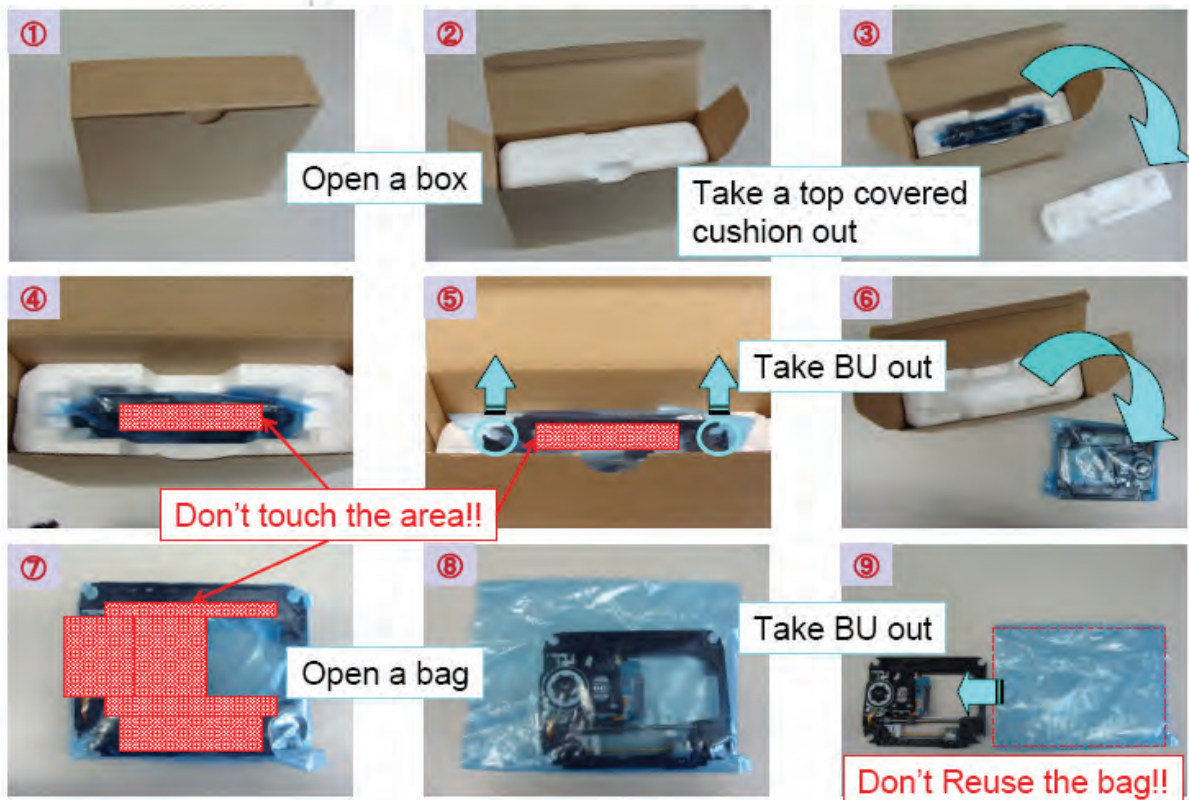

1-4-7. KEM-470AAA/C2RP Packing

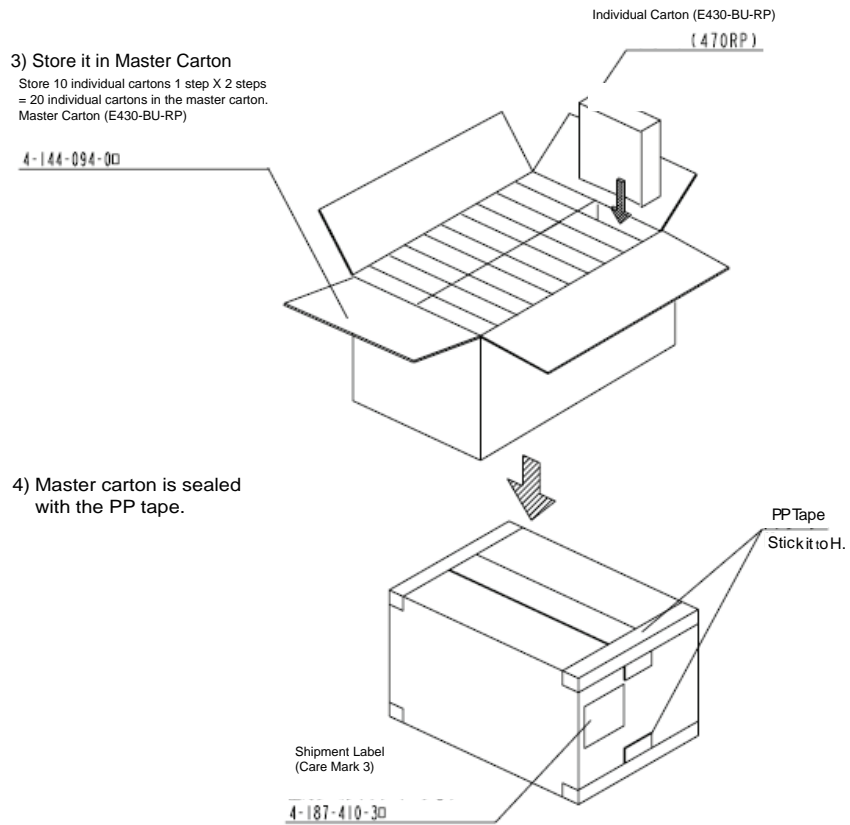
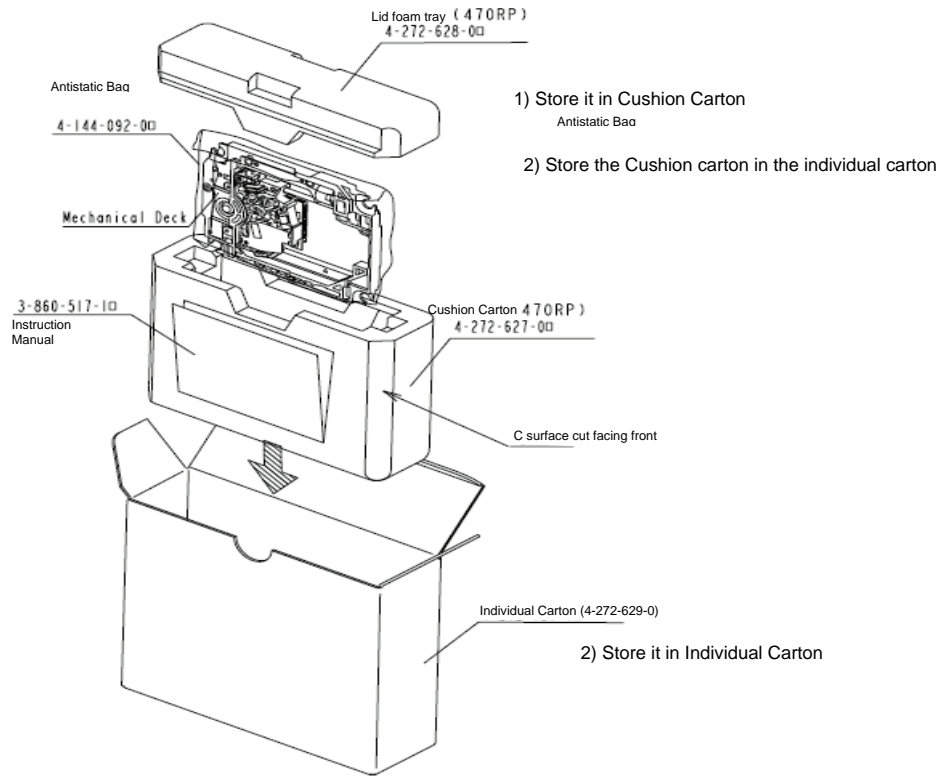

1-4-8. BU Data Decode Jig

- JIG Name: BDPRdec. exe
- Release : 2010.11.26
- Version : 2.0.0.0

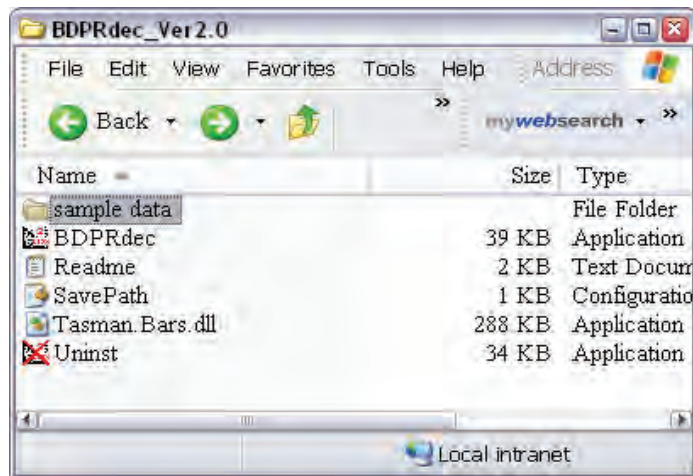

• Software Contents:

- BDPRdec.exe ; Software
- SavePath.ini ; decoded file destination setting file (initial destination is C:¥BuData.txt)
- Tasman.Bars.dll ; decode dll
- Uninst.exe ; unistall BDPRdec.exe from PC

• Installations

1. Unzip files to any PC Folder
2. Check the attached 2D code photo (OK_sample.JPG) drag-and-drop onto BDPRdec.exe, the Password will be required at first time only, no need P/W from second time.
3. If there is the error message (.NET frame work requirements) please apply Microsoft .NET Framework 2.0 (or 2.0 SP1) from Microsoft download site.

STEP 1

Microsoft .NET Framework Version 2.0 Redistributable Package (x86)

<http://www.microsoft.com/downloads/details.aspx?displaylang=en&FamilyID=0856each-4362-4b0d-8edd-aab15c5e04f5>

STEP 2

Microsoft .NET Framework 2.0 Service Pack 1 (x86)

<http://www.microsoft.com/downloads/details.aspx?displaylang=en&FamilyID=79bc3b77-e02c-4ad3-aacf-a7633f706ba5>

*How to use

Case1

Drag-and-drop 2Dcode photo onto BDPRdec.exe

Case2

Drag-and-drop BU data file onto BDPRdec.exe

Data file name be changed to specify format and end of 7 character are defined

Player : ****BDP.txt

Recoder: ****BRD.txt

#You can also enter the file path at the prompt.

*Remarks

Do not change the decoded file name "BuData.txt".

1-4-9. Loading For Service

BDP 6G Loading Ass'y service parts consists from 3 parts.

- ①Holder, Clamper Assy
- ②Loading Assy
- ③Holder FFC

Currently these parts are producing 2 vendors. But the **THERE IS NO COMPATIBILITY**
So, please **DO NOT MIX** the ① and ② of Loading for service and original Loading.

“Loading for service” A-1750-926-A

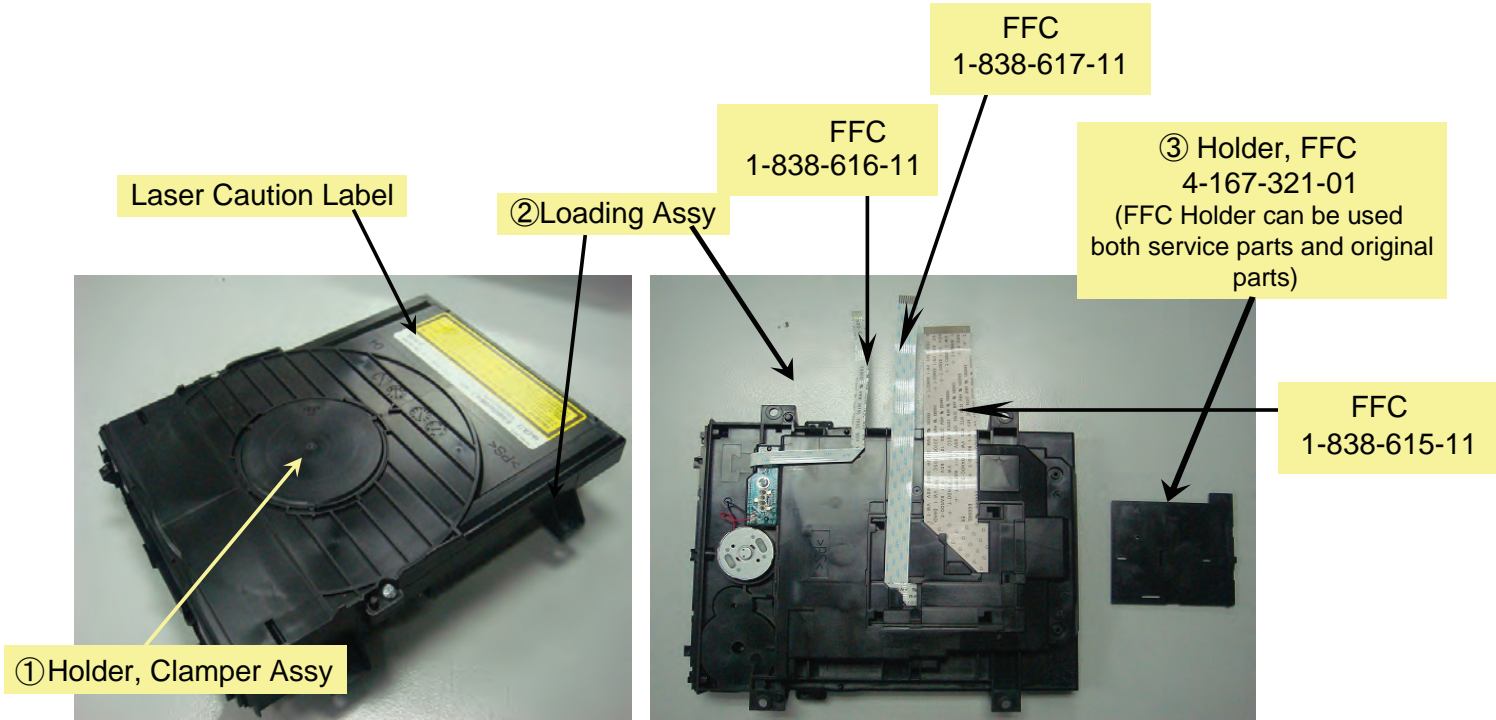

1-4-10. Laser Caution Label

The Loading Ass'y service parts does not have Laser Caution Label.
So that please reuse the original Laser Caution label and paste it on top of new Loading Ass'y.

Limit Sample
Following peel off condition are acceptable



In case of BU assy replacement:

1. OP related data for new assy is controlled by BU factory
2. All of data is recorded into a barcode label
3. The label is put on the assy
4. Service parts will be followed
5. In service, the data should be read out from problem assy
6. The read data should be saved to new assy

Fact finding:

1. The label is "DATA MATRIX" format
2. The number of data is 91 words
3. The method of reading and saving is required when BU and main board are replaced.

New service method

1. All of BU data on the barcode label is shot by digital camera in order to make a JPEG file of BU data.
2. Application software in the PC makes digital data from JPEG file.
3. The converted data is stored to USB memory.
4. The USB memory is connected to BDP 6G unit.
5. In service mode, there is a command to save the data from USB memory to board memory.

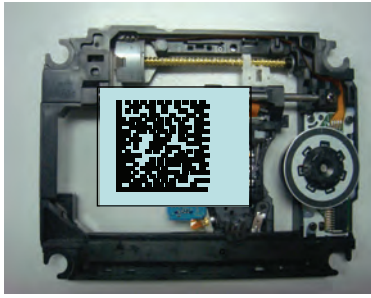

Shoot the barcode
Format is JPEG



Application Software
Data convert from
JPEG → TEXT



Save the TEXT data



USB device is connected
to  symbol on the
rear unit, and the TEXT
data as new data is
loaded to unit by service
mode.

Description: BDPRdec.exe

When instruction to PC, password is required.

The password will be supplied to only service HQ, and service center name, q'ty and all of software registered information should be maintained by service HQ, and Video will ask to report the registration information.

1-5. REAR PANEL ASSEMBLY CAUTION

Whenever you need to assemble the rear panel, please make sure that the Ethernet connector (CN801) Top Contact Springs are in good condition with height $\geq 2.0\text{mm} \pm 0.5\text{mm}$ (refer to Fig 1)

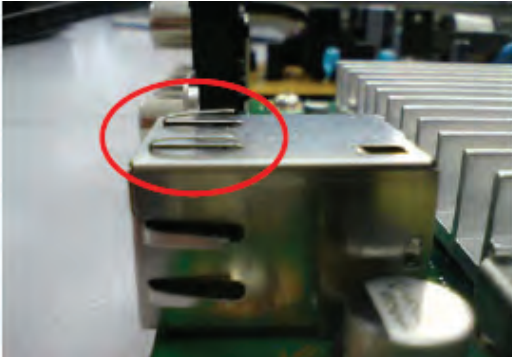

Fig.1

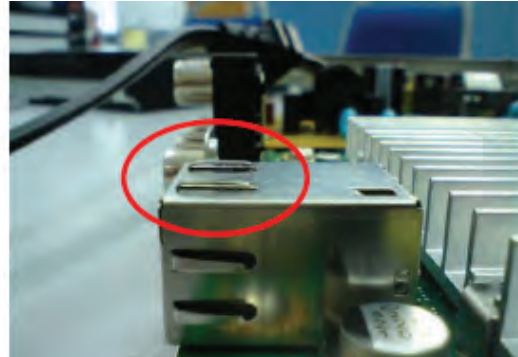
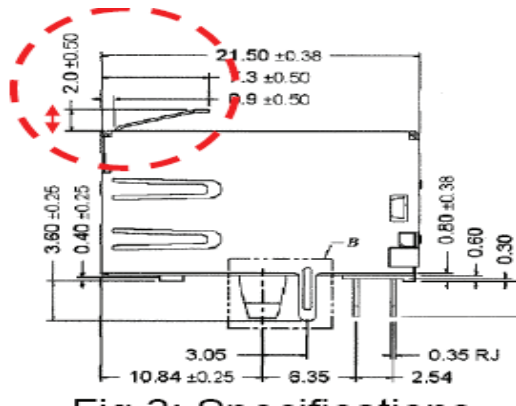

Fig.2

If the Top Contact Springs are in flat condition (Fig2), please lift them up to good condition before assembling the rear panel.



Good Contact



Spec.

When assembling the rear panel, please ensure good contact between the Top Contact Springs to the rear panel.

SECTION 2 DISASSEMBLY

- This set can be disassembled in the order shown below.

2-1. DISASSEMBLY FLOW

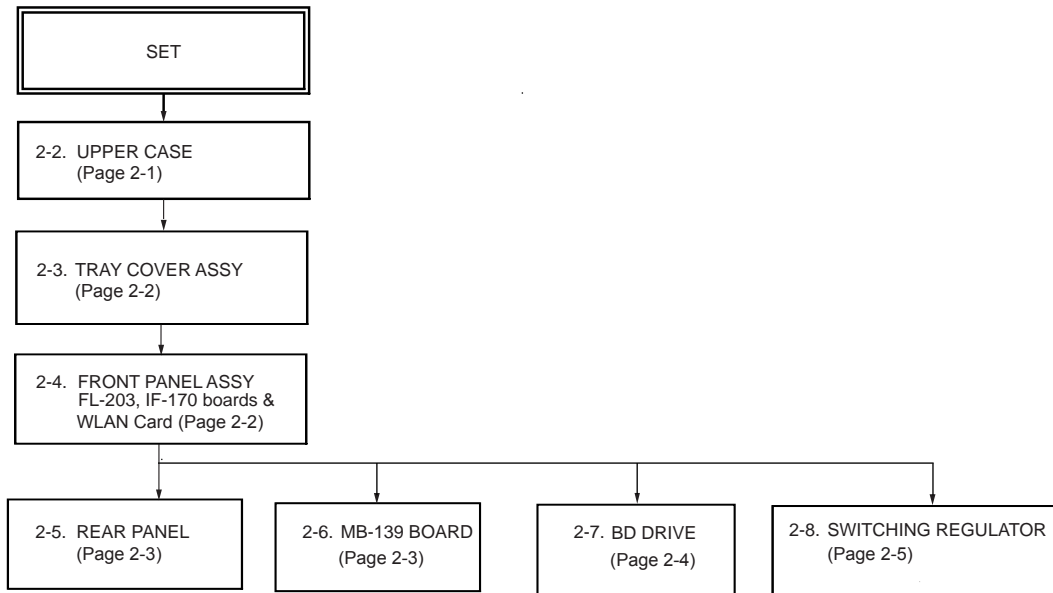

Note: Follow the disassembly procedure in the numerical order given.

2-2. UPPER CASE

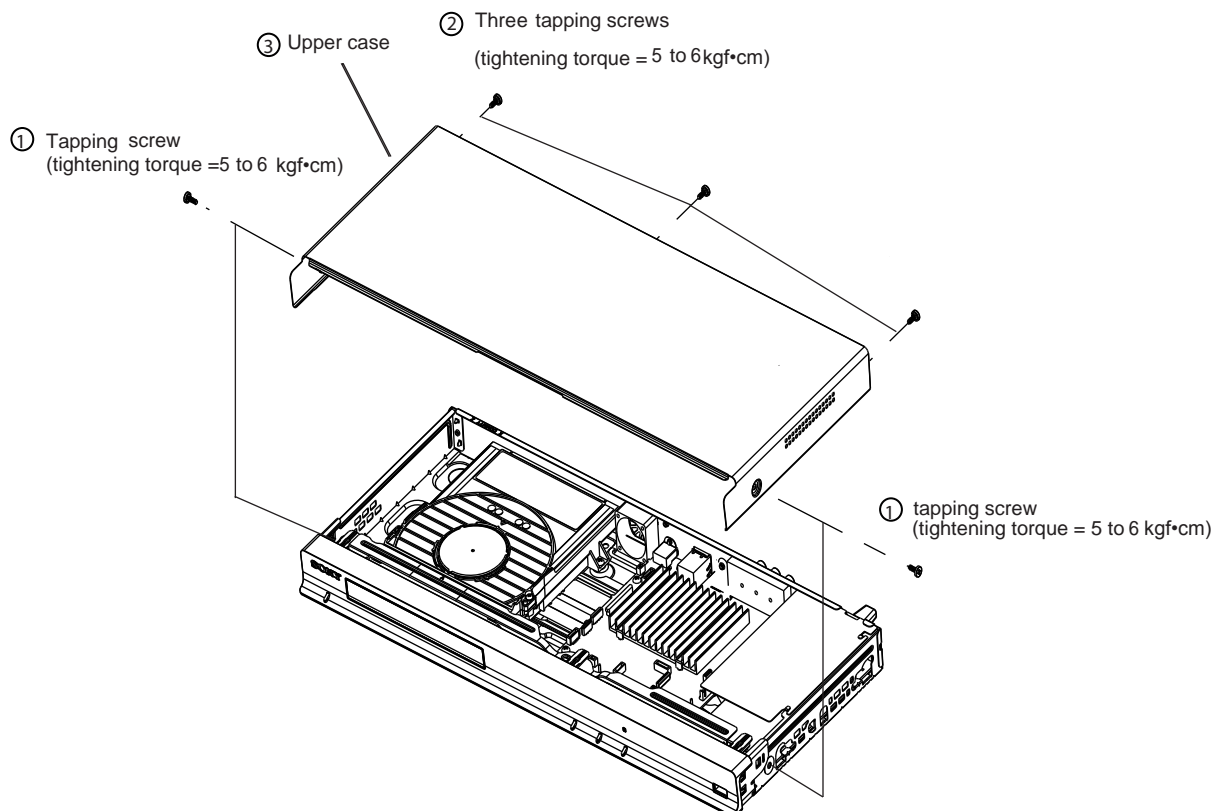

2-3. TRAY COVER ASSY

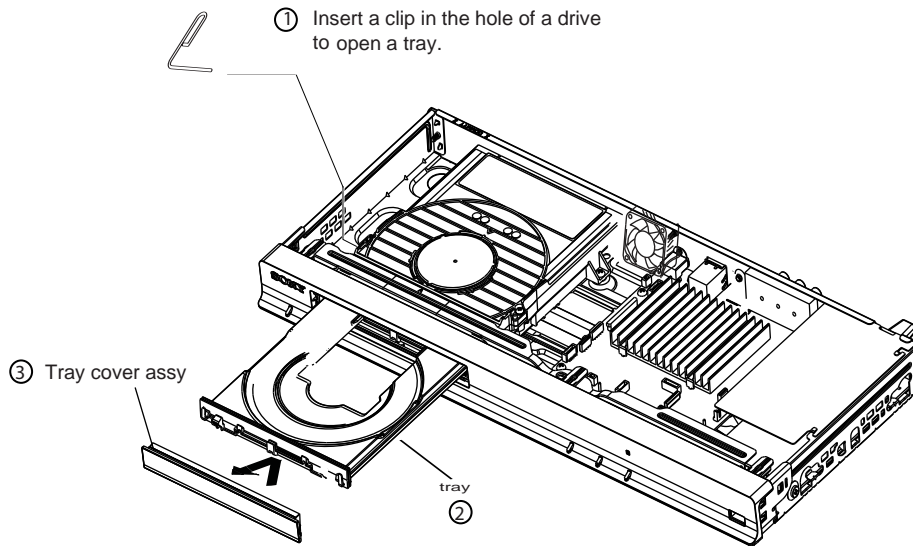

2-4. FRONT PANEL ASSY, FL-203 , IF-170 BOARD AND WLAN CARD

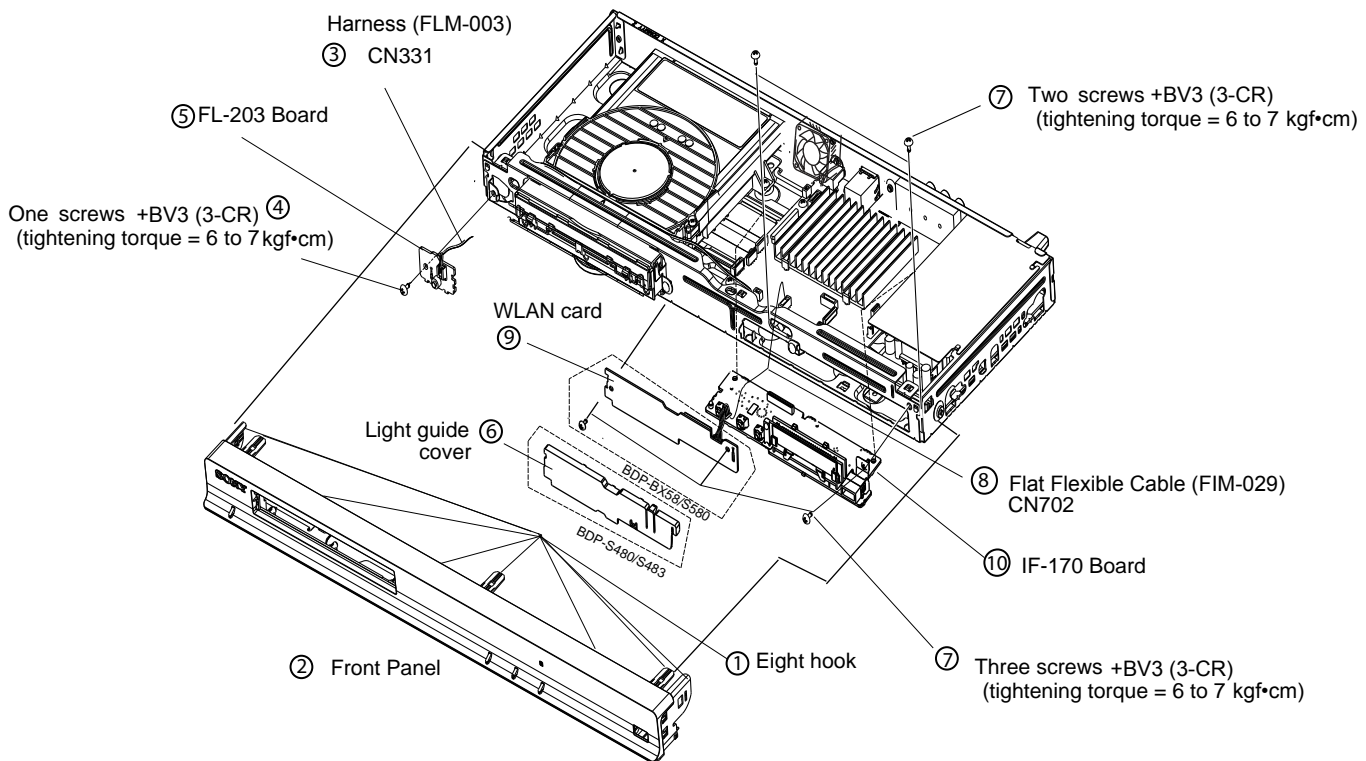

2-5. REAR PANEL BLOCK

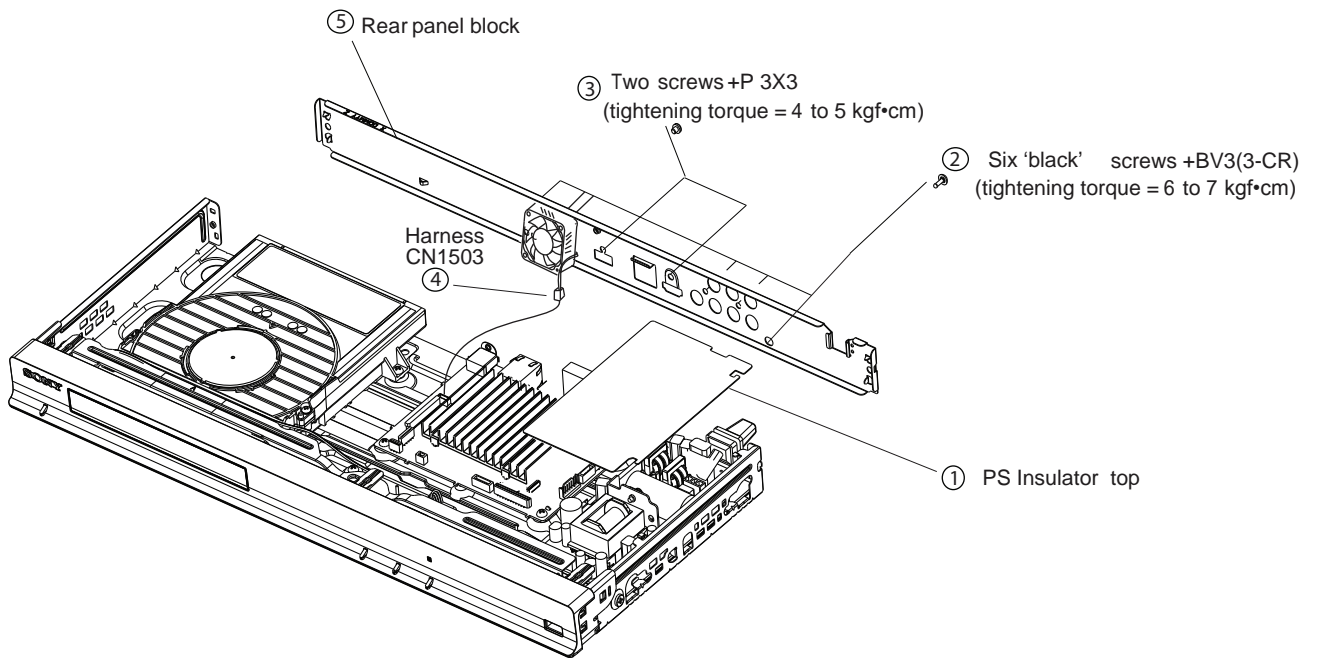

2-6. MB-139 BOARD

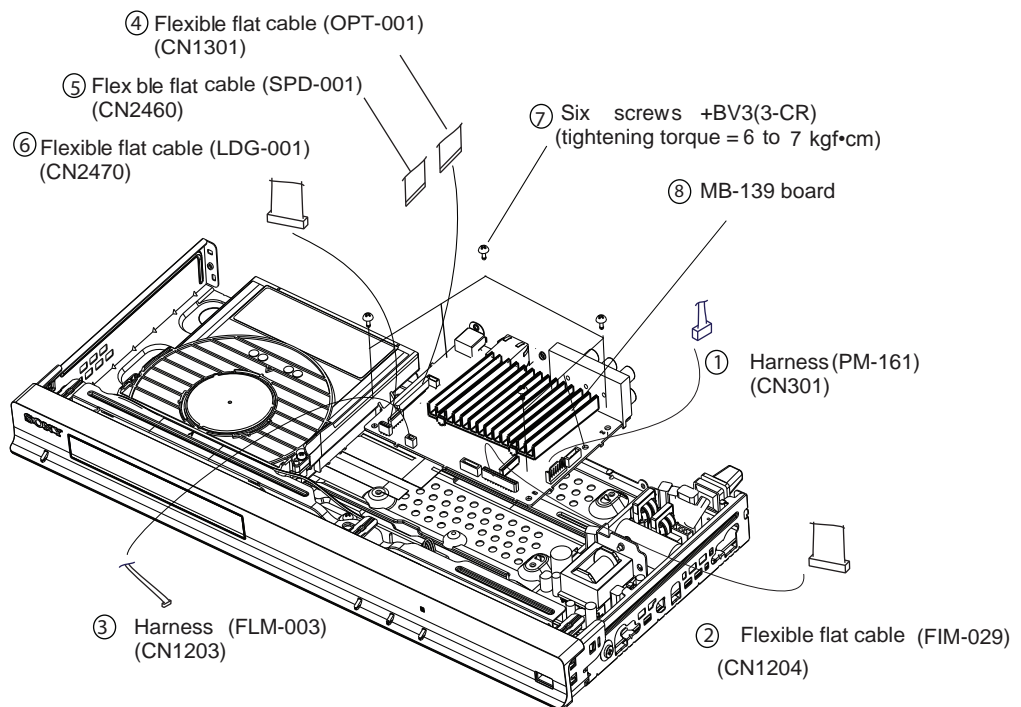

2-7. BD DRIVE

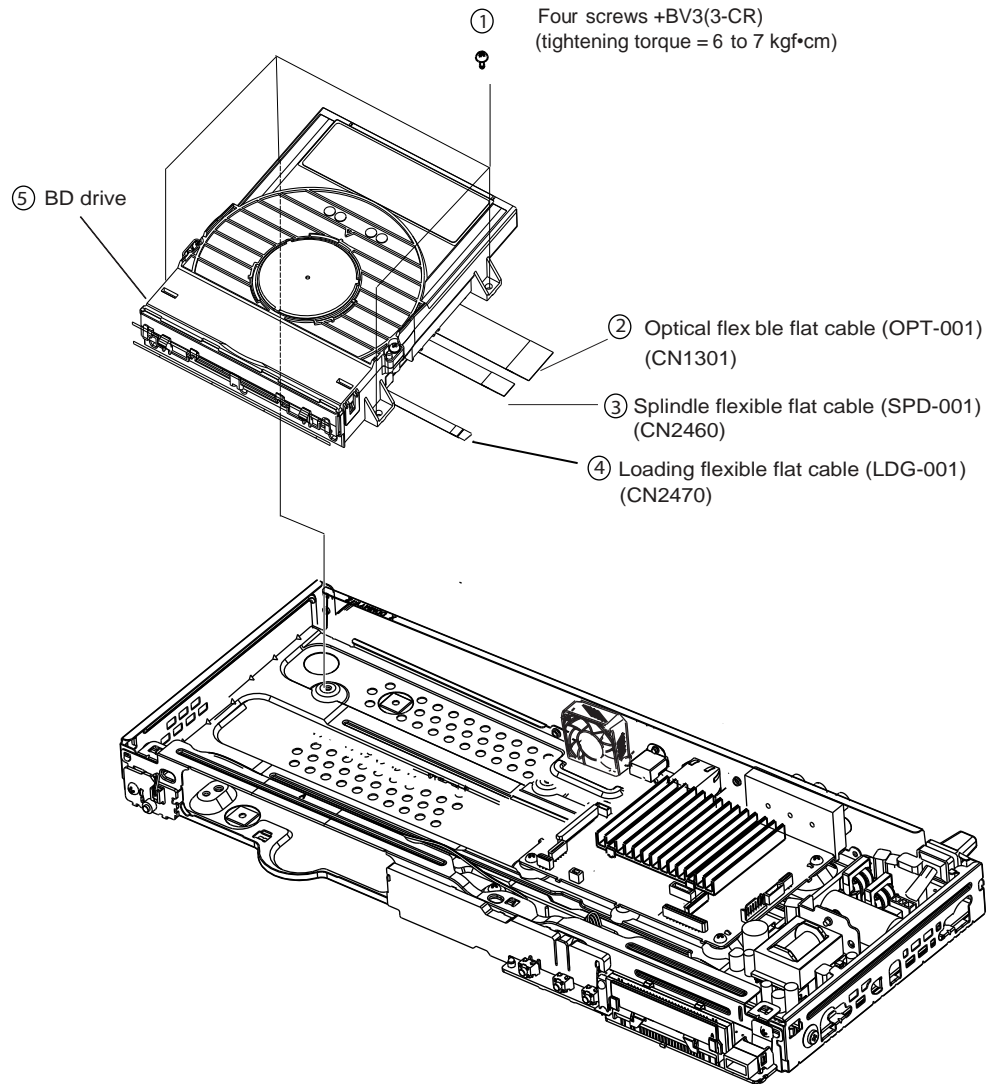

2-8. SWITCHING REGULATOR

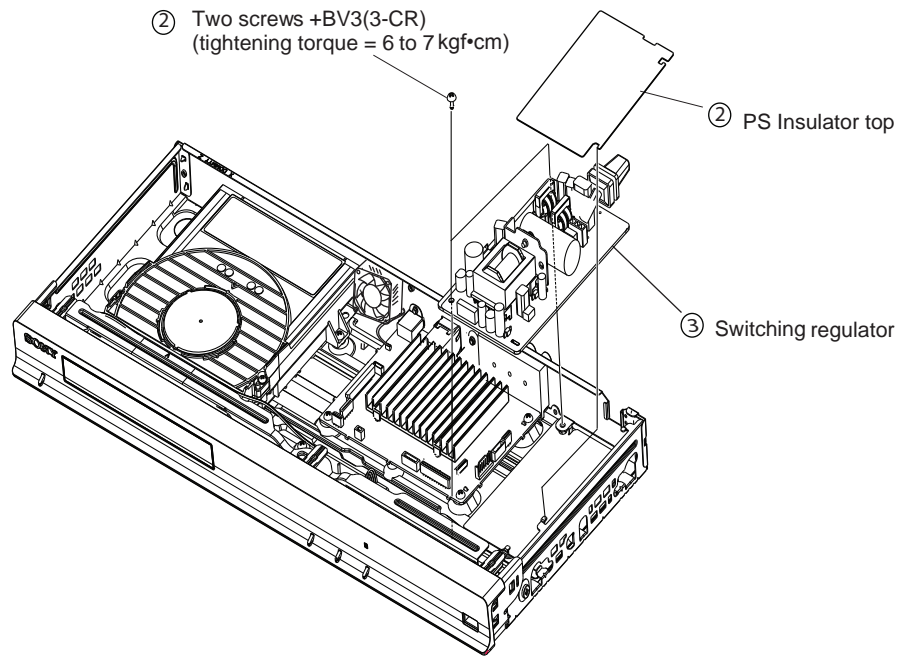

2-9. CIRCUIT BOARDS LOCATION

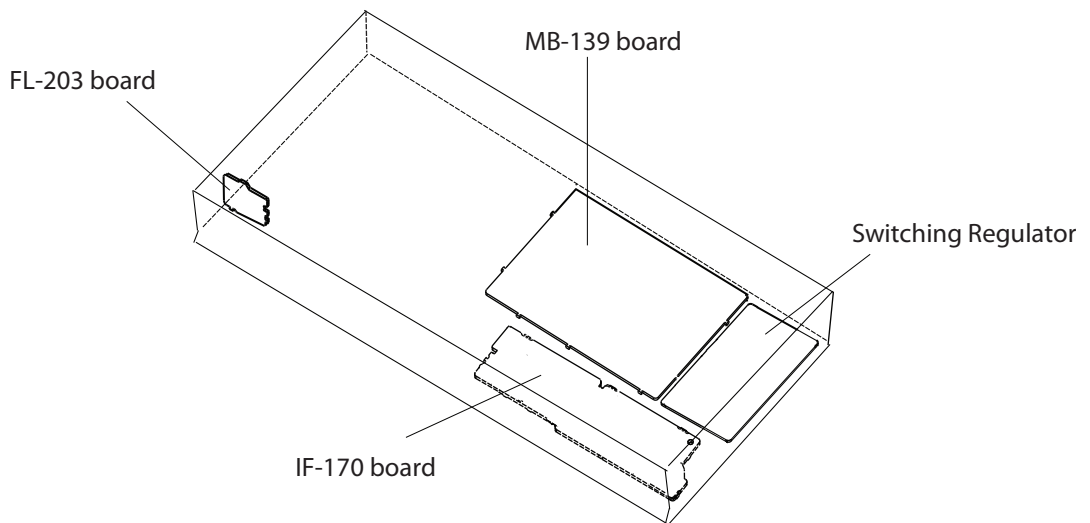

SECTION 3
BLOCK DIAGRAM

3-1. OVERALL BLOCK DIAGRAM

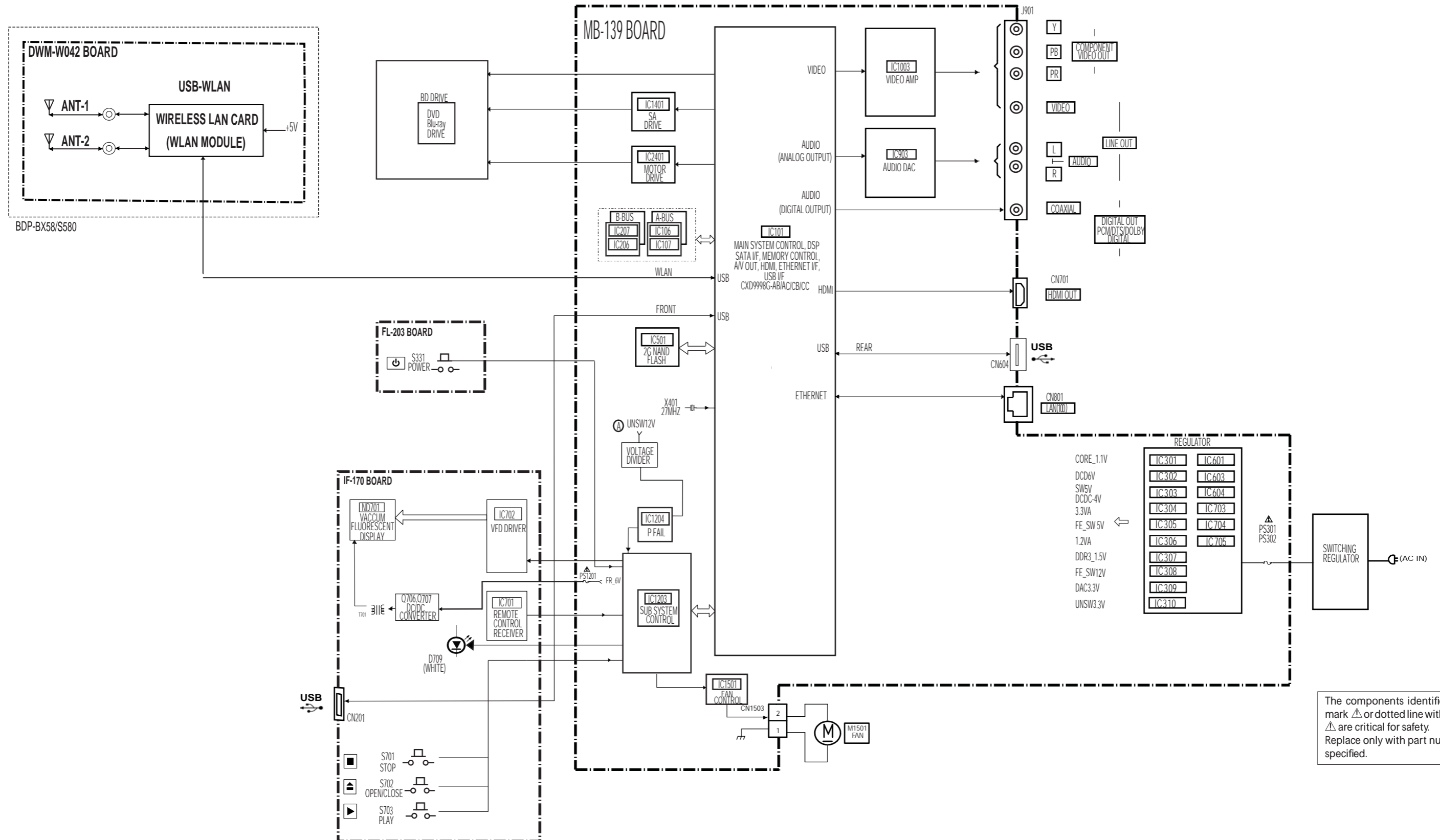

3-2. DSP BLOCK DIAGRAM

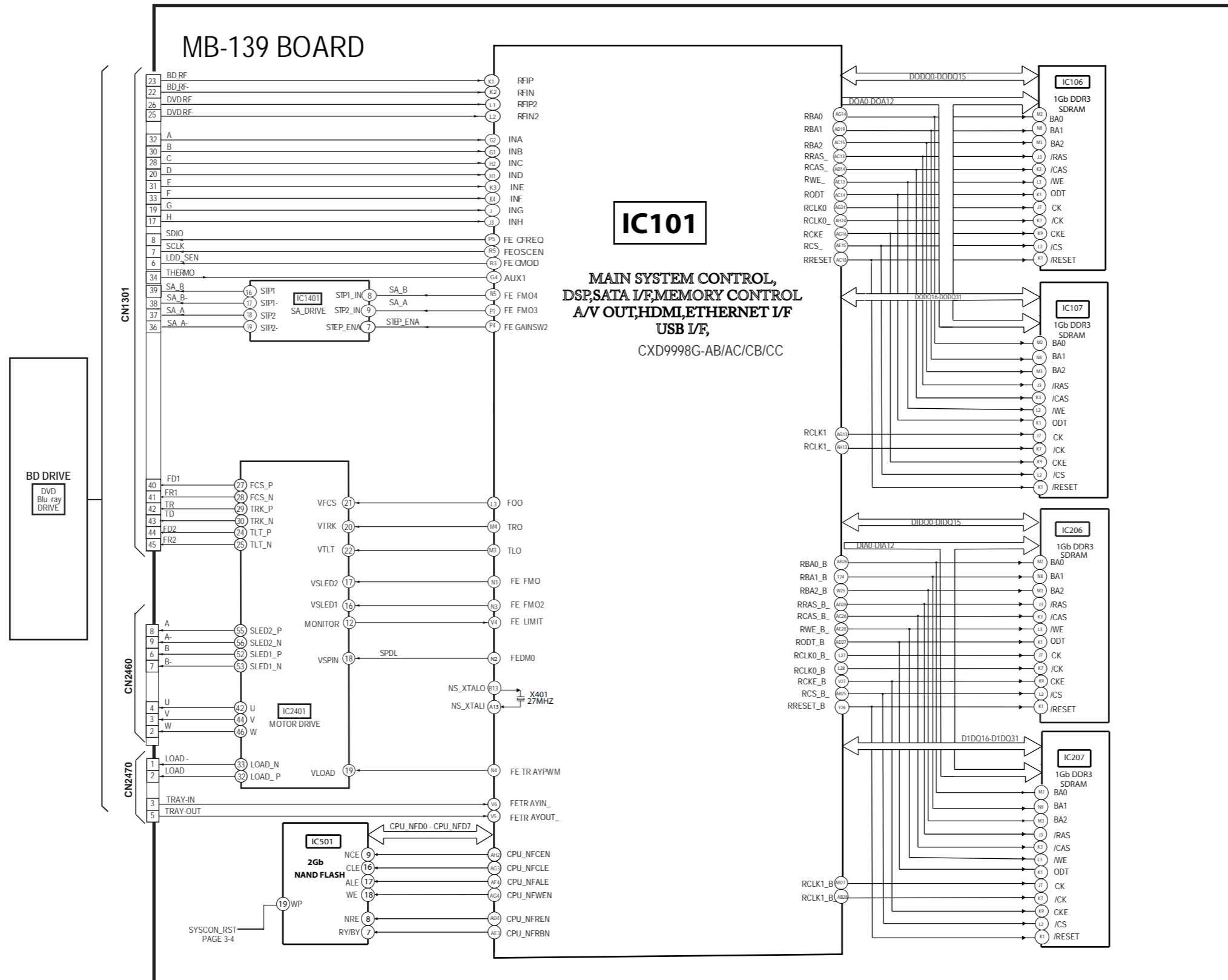

3-3. AV OUT BLOCK DIAGRAM

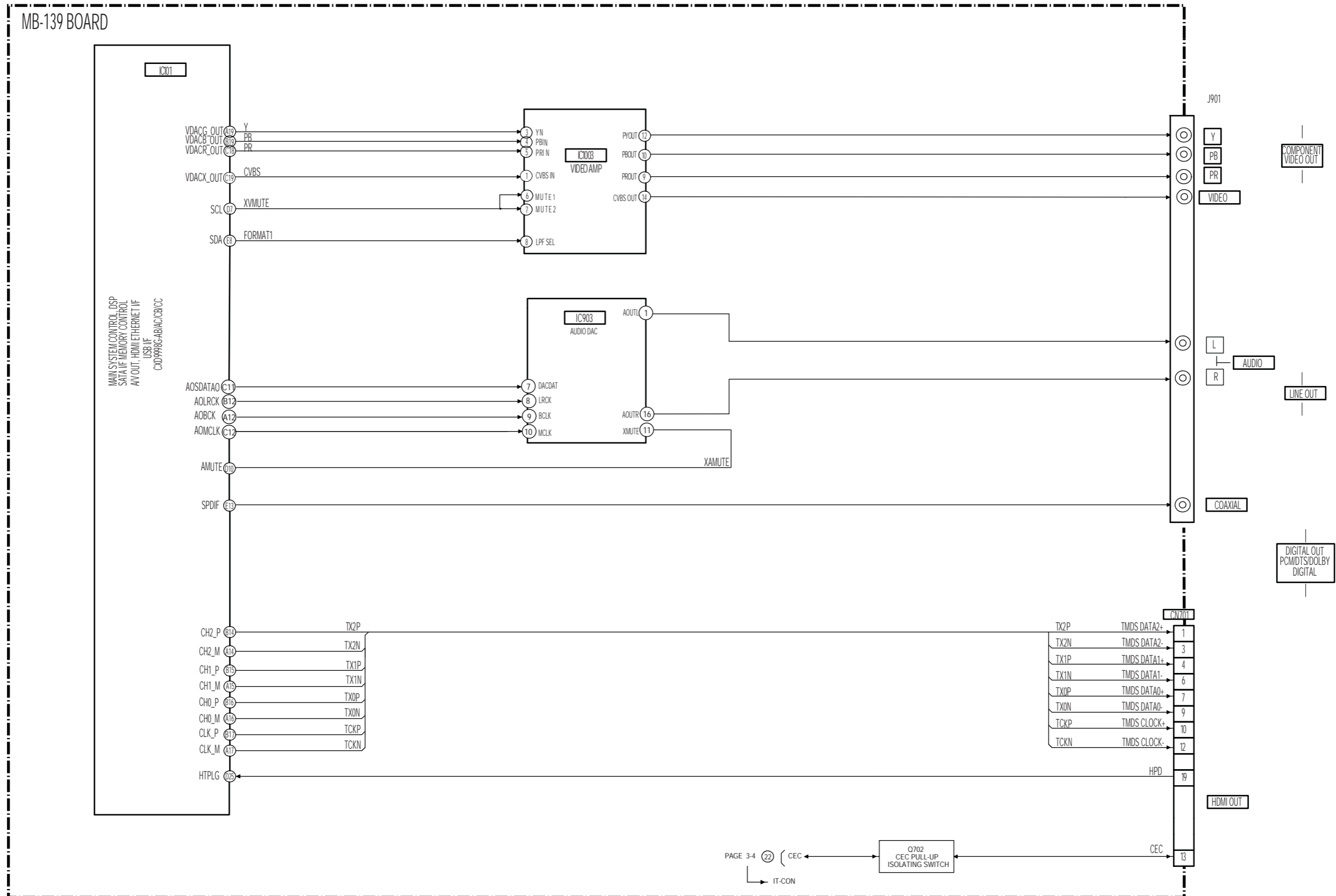

3-4. USB/ETHER/WLAN BLOCK DIAGRAM

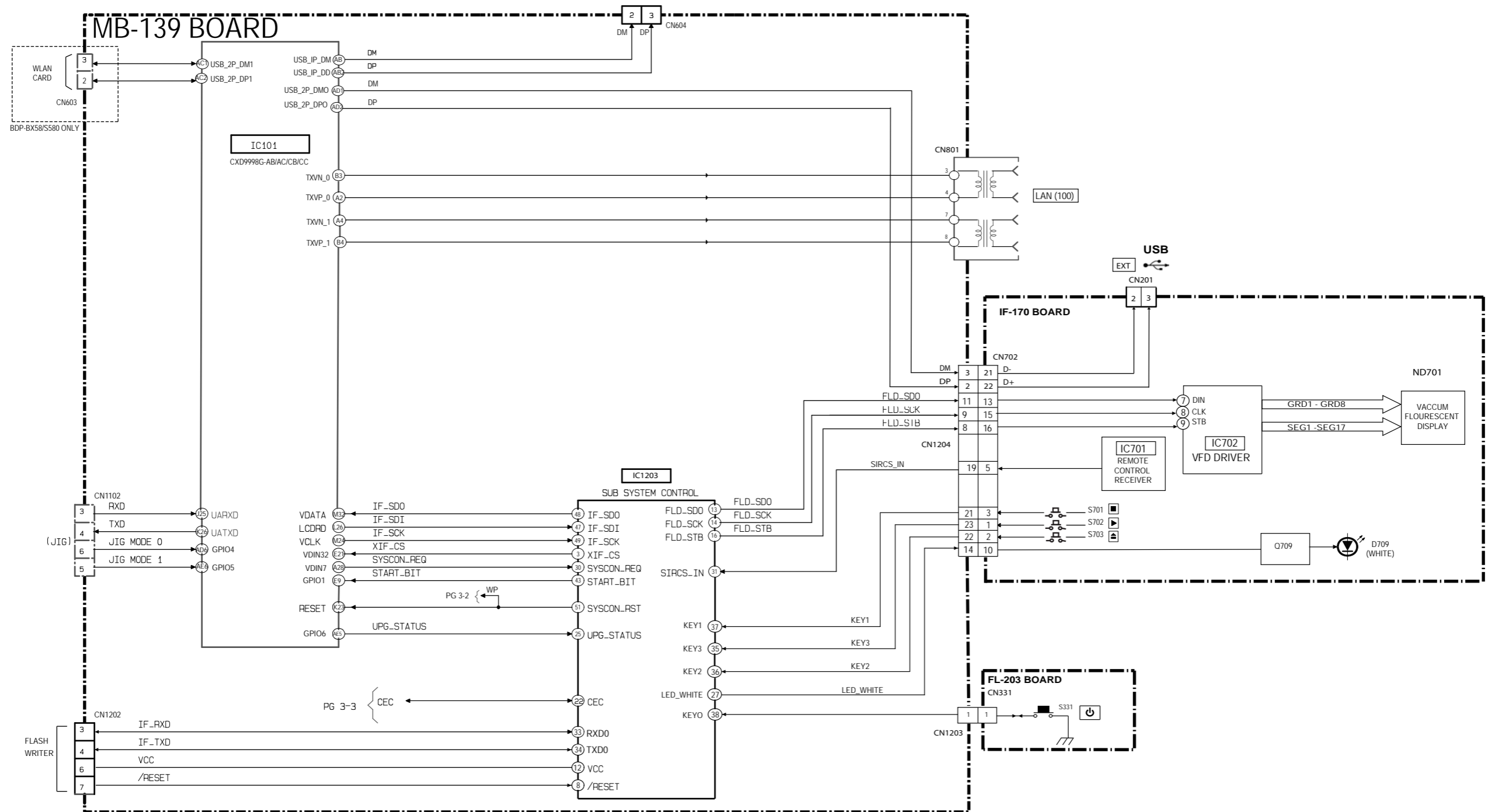



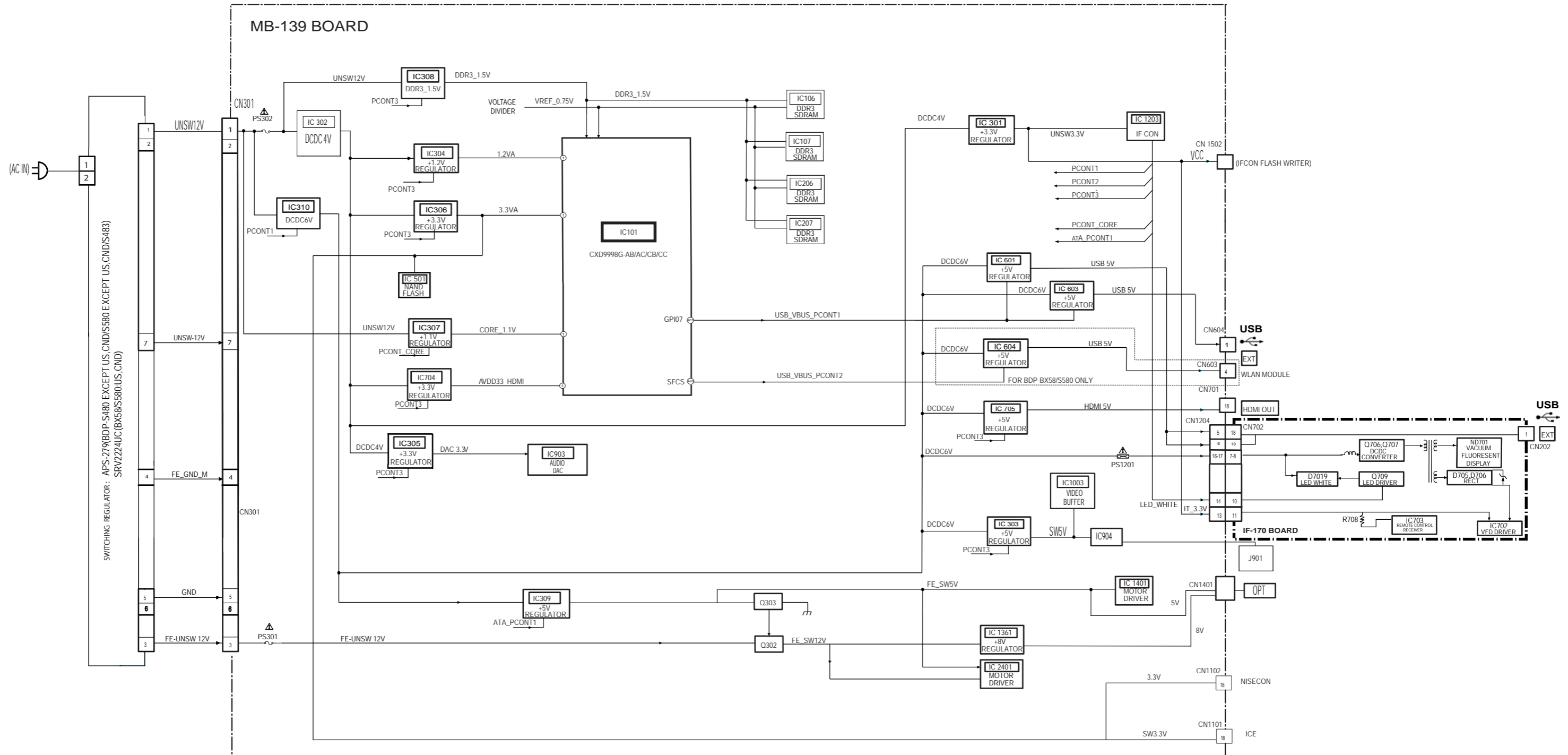



3.5 POWER BLOCK DIAGRAM



The components identified by mark \triangle or dotted line with mark \triangle are critical for safety. Replace only with part number specified.

SECTION 4 SCHEMATIC DIAGRAM

4-1. THIS NOTE IS COMMON FOR SCHEMATIC DIAGRAMS

- All capacitors are in μF unless otherwise noted. $\text{pF} : \mu\mu\text{F}$.
50V or less are not indicated except for electrolytics and tantalums.
- All resistors are in ohms, 1/4 W (Chip resistors : 1 /10 W) un-less otherwise specified.
 $\text{k}\Omega=1000\Omega$, $\text{M}\Omega=1000\text{k}\Omega$.
- % : indicates tolerance.
- Caution when replacing chip parts.
New parts must be attached after removal of chip.
Be careful not to heat the minus side of tantalum capacitor, because it is damaged by the heat.
- Constants of resistors, capacitors, ICs and etc with XX indicate that they are not used.
In such cases, the unused circuits may be indicated.
- All variable and adjustable resistors have characteristic curve B, unless otherwise noted.
-  : nonflammable resistor
-  : fusible resistor
-  : panel designation
- f : internal component.
-  : adjustment for repair.
-  : B+ Line
-  : B- Line
- Circled numbers refer to waveforms.
- Voltages are dc between measurement point.
- Readings are taken with a color-bar signals on Blu-ray disc.
- Readings are taken with a digital multimeter (DC 10M Ω).
- Voltage variations may be noted due to normal production tolerances.

Note:

The components identified by mark \triangle or dotted line with mark \triangle are critical for safety.
Replace only with part number specified.

Note:

Les composants identifiés par une marque \triangle sont critiques pour la sécurité.
Ne les remplacer que par une pièce portant le numéro spécifié.

When indicating parts by reference number, please include the board name.

4-2. FRAME SCHEMATIC DIAGRAM

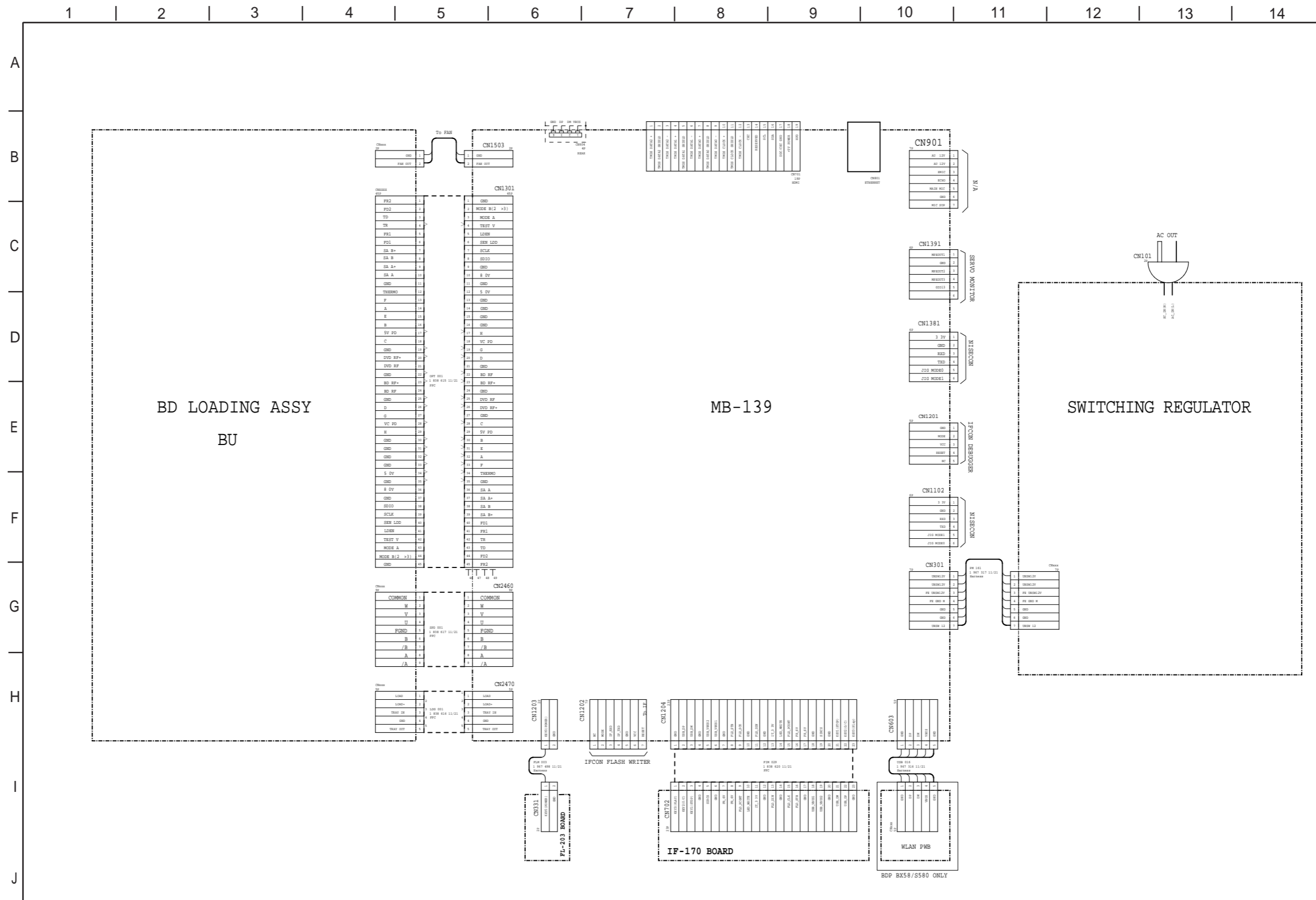

4-3. IF-170 BOARD (FRONT RIGHT)SCHEMATIC DIAGRAM •See page 5-3 for printed wiring board.

- Ref. No.: IF-170 board; 20,000 series -

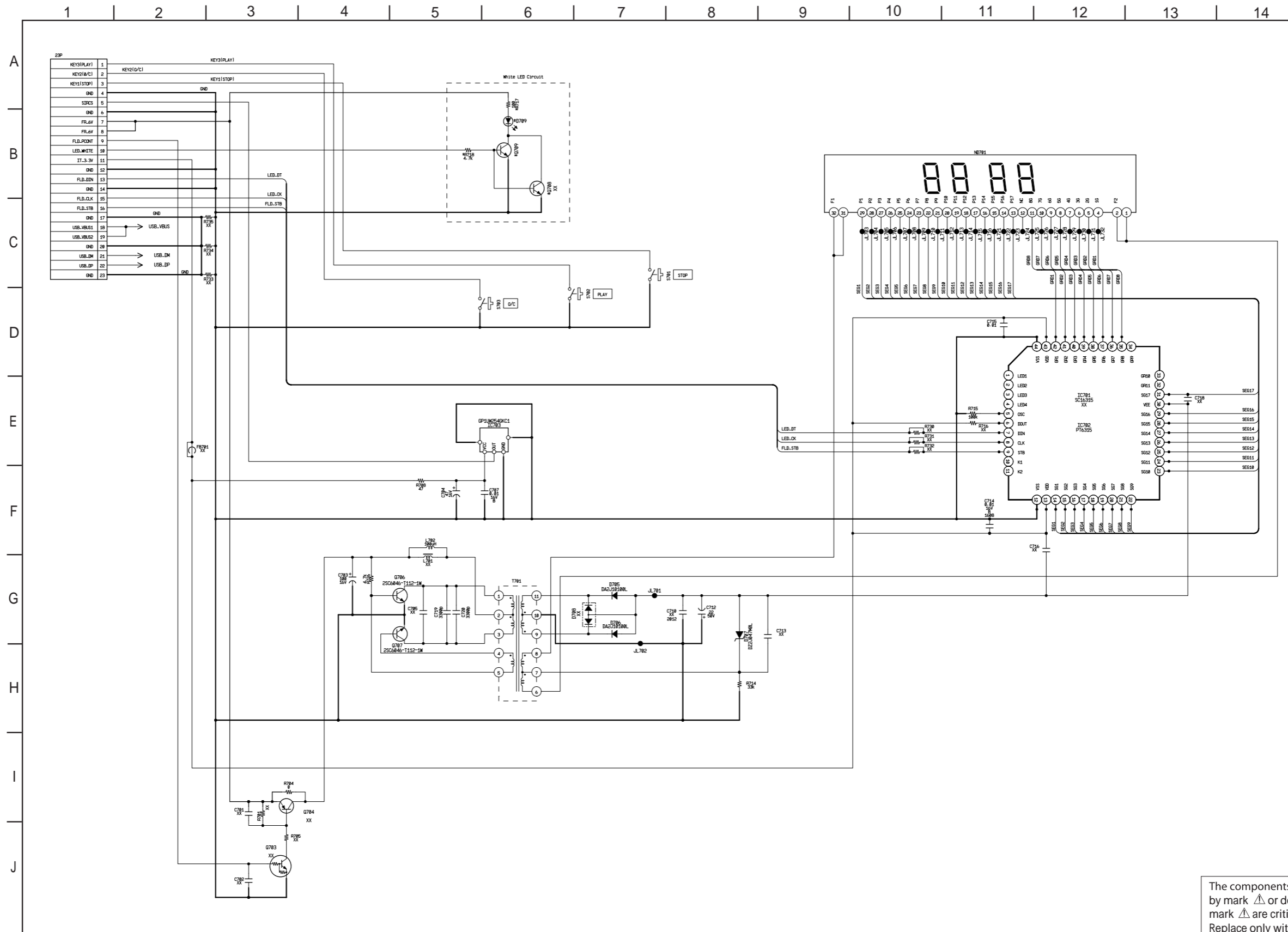

The components identified by mark \triangle or dotted line with mark \triangle are critical for safety. Replace only with part number specified.

4-4. IF-170 BOARD (USB FRONT) SCHEMATIC DIAGRAM

- Ref. No.: IF-170 board; 20,000 series -

• See page 5-3 for printed wiring board.

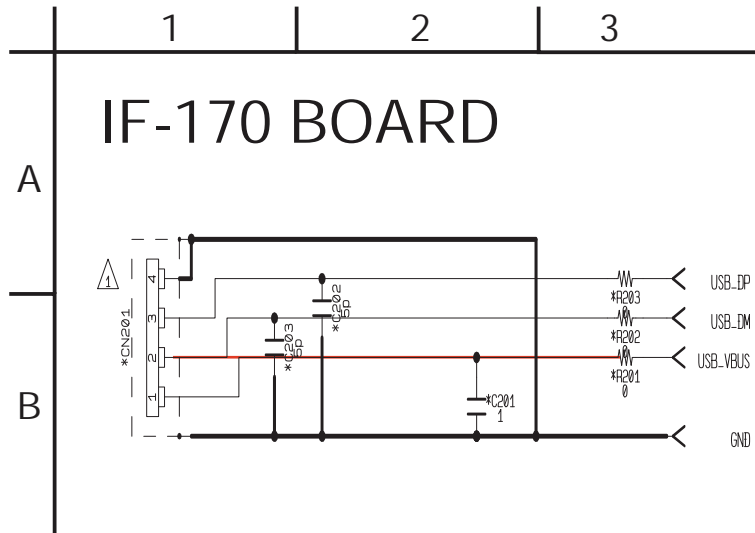

4-5. FL-203 BOARD (POWER) SCHEMATIC DIAGRAM

- Ref. No.: FL-203 board; 20,000 series -

- See page 5-3 for printed wiring board.

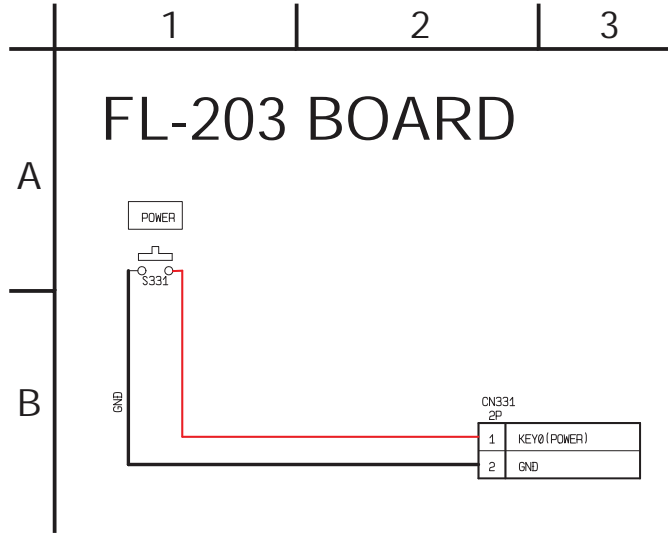

4-7. MB-139 BOARD (CXD9998G-AB/AC/CB/CC) SCHEMATIC DIAGRAM (2/17) • See page 5-4 for printed wiring board.

- Ref. No.: MB-139 board; 10,000 series

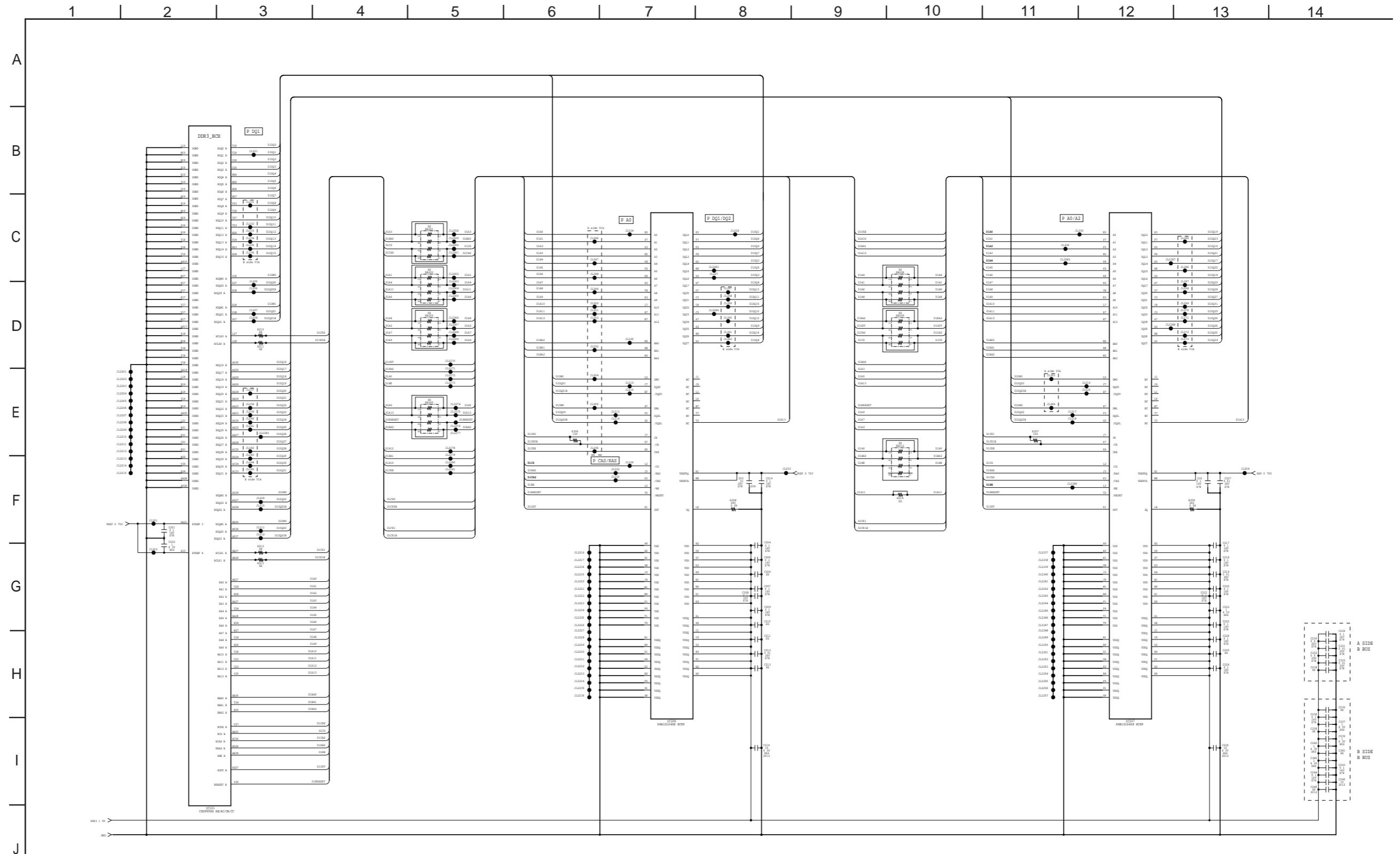

SYSTEM,DDR3 B
MB-139

4-6 . MB-139 BOARD (CXD9998G-AB/AC/CB/CC)SCHEMATIC DIAGRAM (1/17) • See page 5-4 for printed wiring board.

- Ref. No.: MB-139 board; 10,000 series

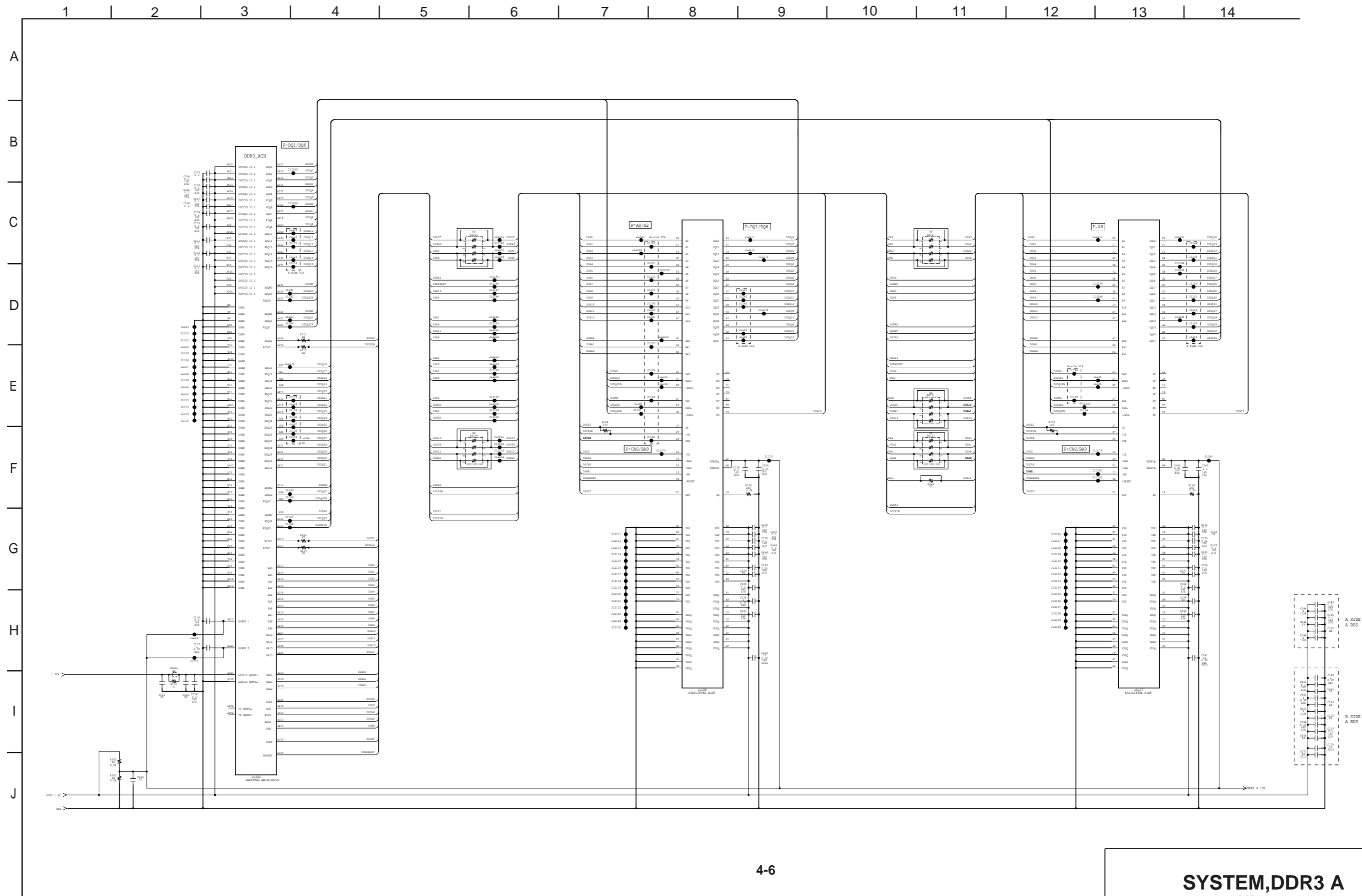

4-8. MB-139 BOARD (CXD9998G-AB/AC/CB/CC) SCHEMATIC DIAGRAM (3/17) • See page 5-4 for printed wiring board.

- Ref. No.: MB-139 board; 10,000 series

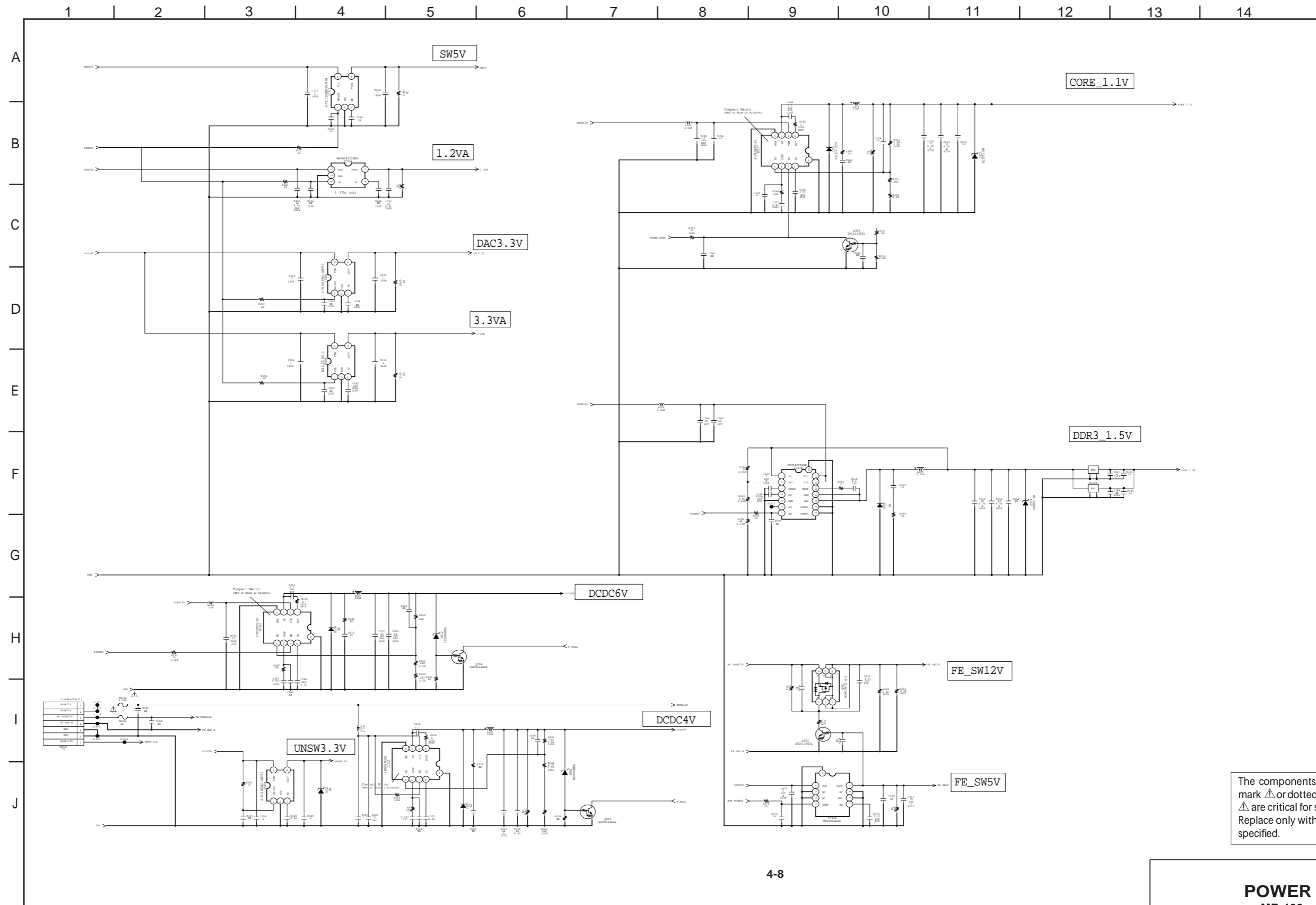

4-9. MB-139 BOARD (CXD9998G-AB/AC/CB/CC) SCHEMATIC DIAGRAM (4/17) • See page 5-4 for printed wiring board.

- Ref. No.: MB-139 board; 10,000 series

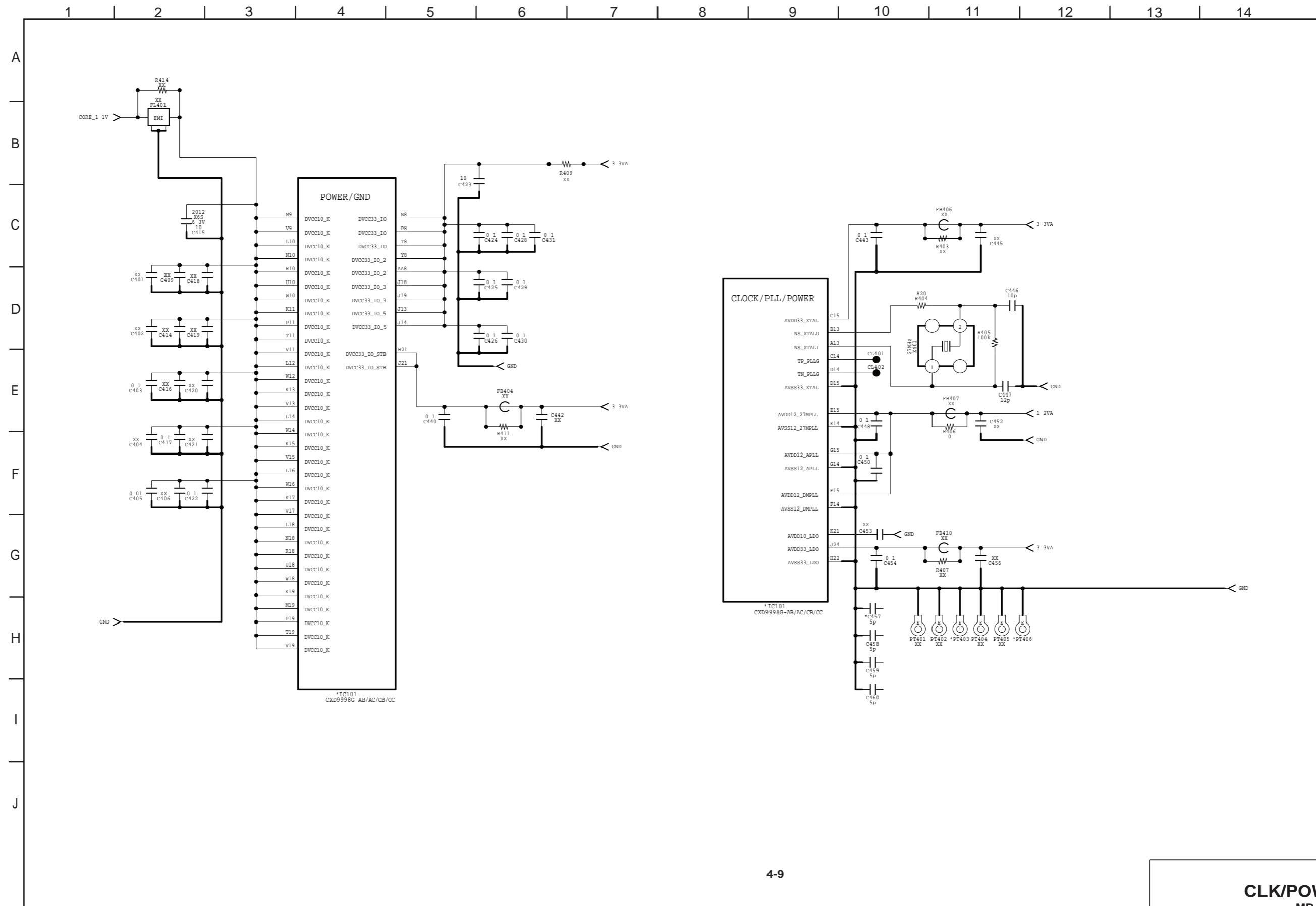

4-10. MB-139 BOARD (CXD9998G-AB/AC/CB/CC) SCHEMATIC DIAGRAM (5/17) • See page 5-4 for printed wiring board.

- Ref. No.: MB-139 board; 10,000 series

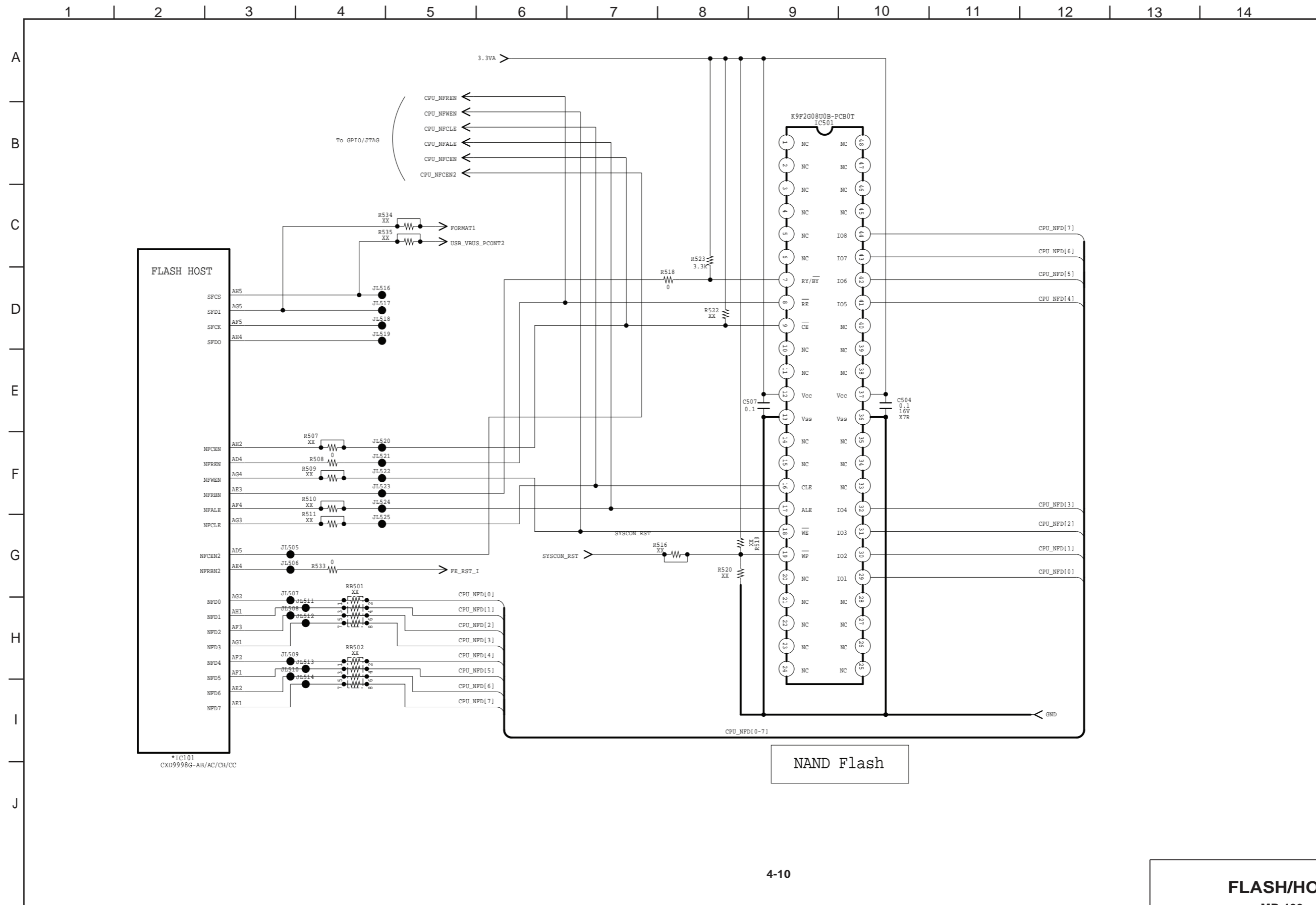

4-11. MB-139 BOARD (CXD9998G-AB/AC/CB/CC) SCHEMATIC DIAGRAM (6/17) • See page 5-4 for printed wiring board.

- Ref. No.: MB-139 board; 10,000 series

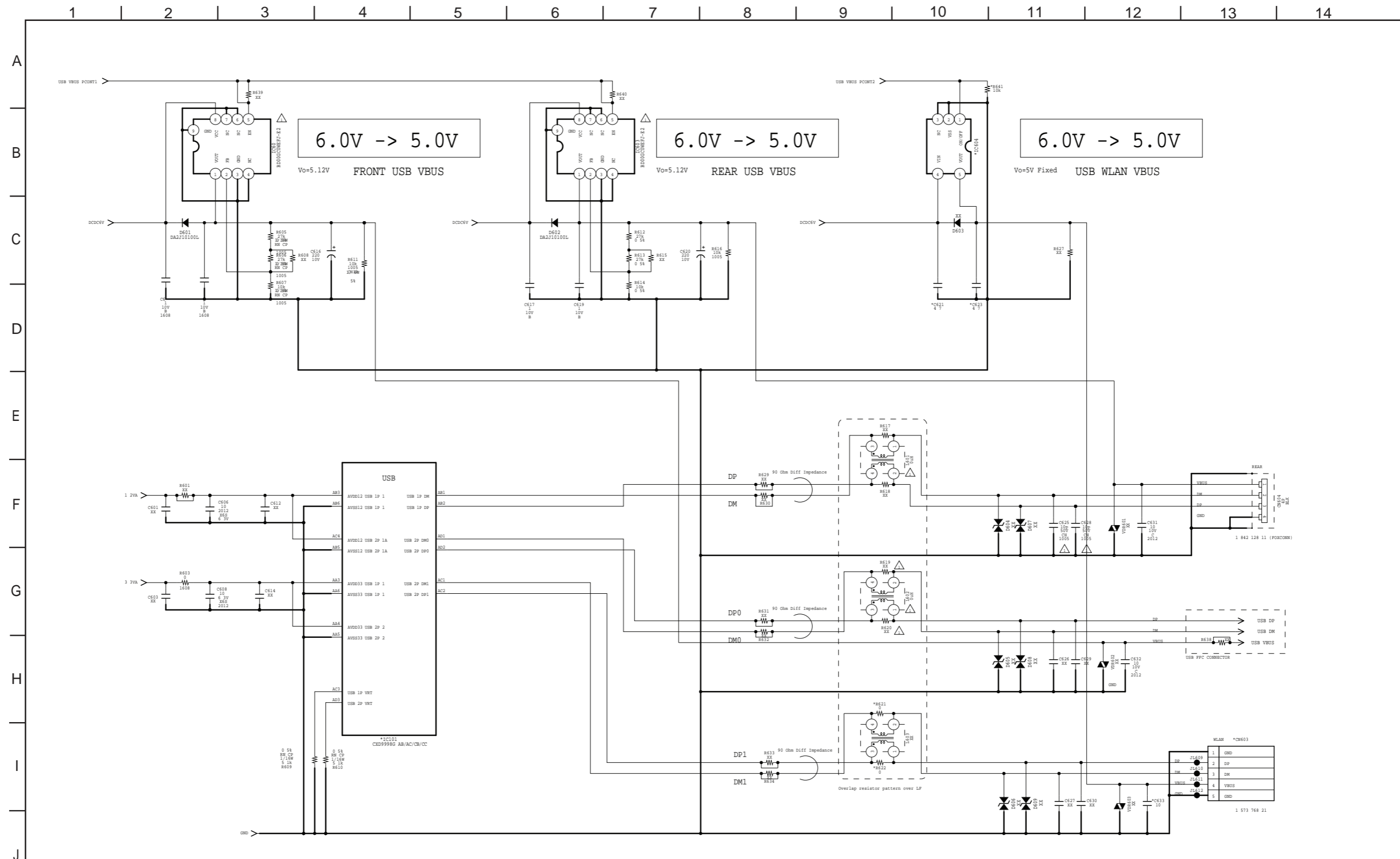

4-12. MB-139 BOARD (CXD9998G-AB/AC/CB/CC) SCHEMATIC DIAGRAM (7/17) • See page 5-4 for printed wiring board.

- Ref. No.: MB-139 board; 10,000 series

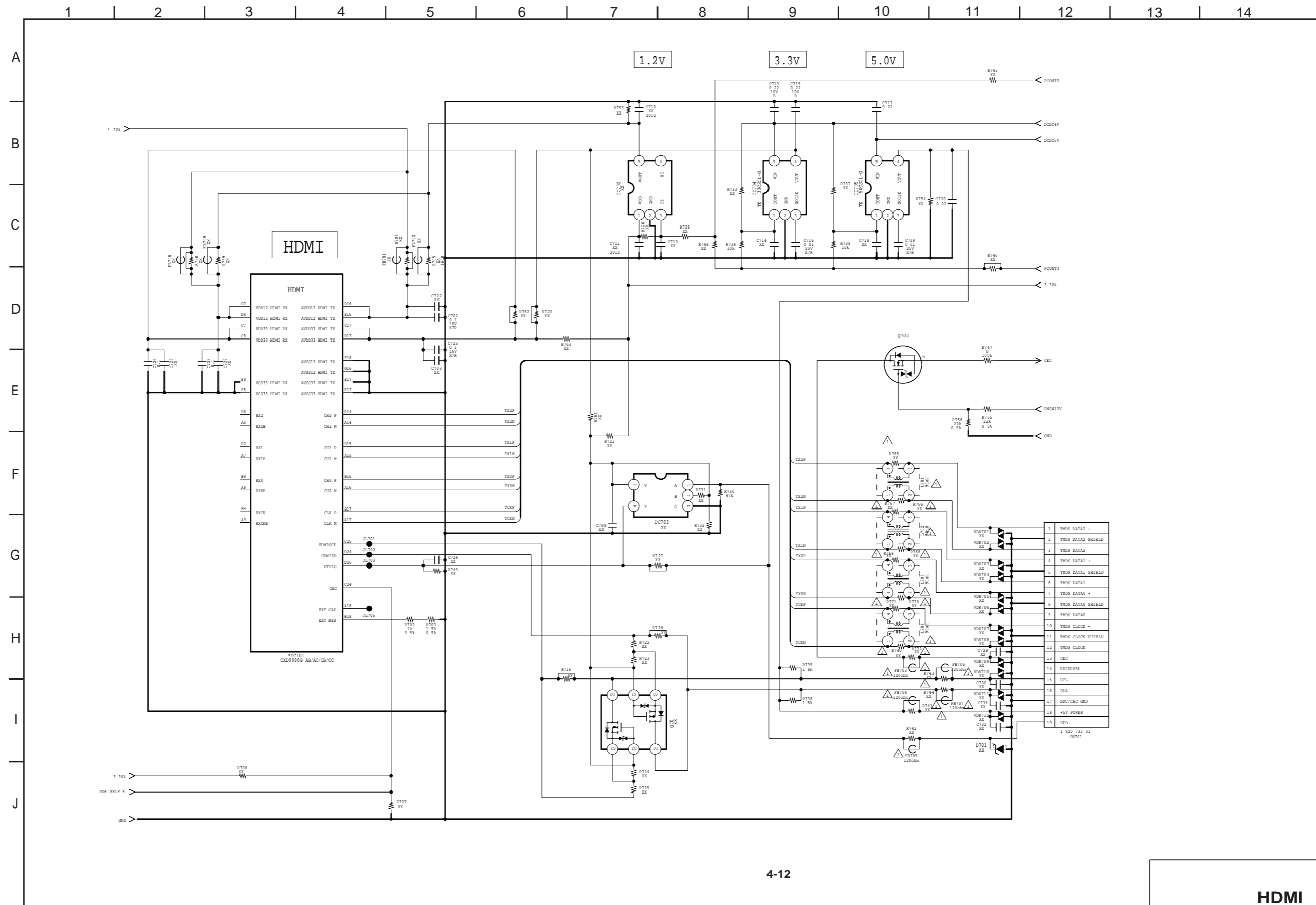

HDMI
MB-139

4-13.MB-139 BOARD (CXD9998G-AB/AC/CB/CC) SCHEMATIC DIAGRAM (8/17) • See page 5-4 for printed wiring board.

- Ref. No.: MB-139 board; 10,000 series

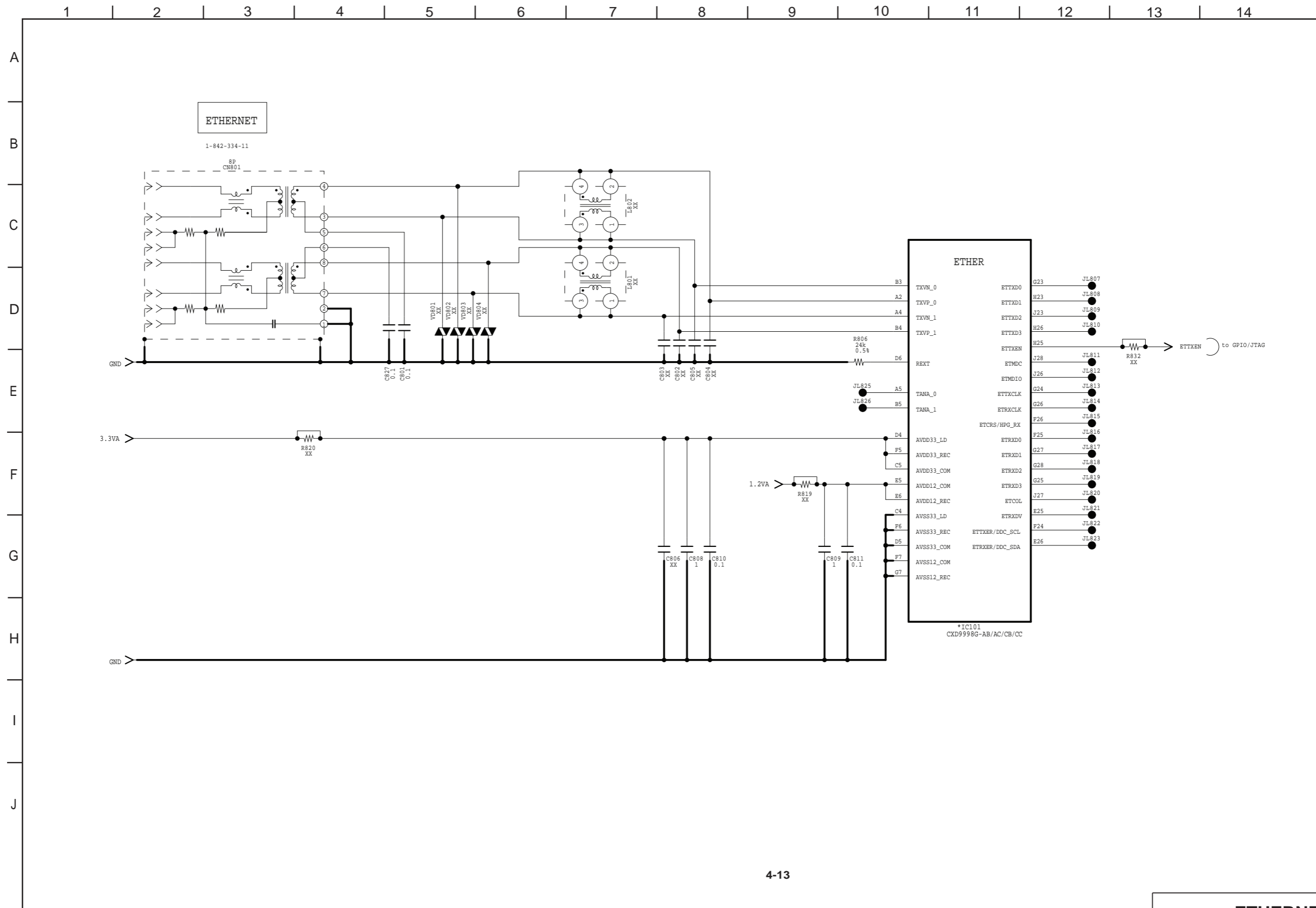

4-14. MB-139 BOARD (CXD9998G-AB/AC/CB/CC) SCHEMATIC DIAGRAM (9/17) • See page 5-4 for printed wiring board.

- Ref. No.: MB-139 board; 10,000 series

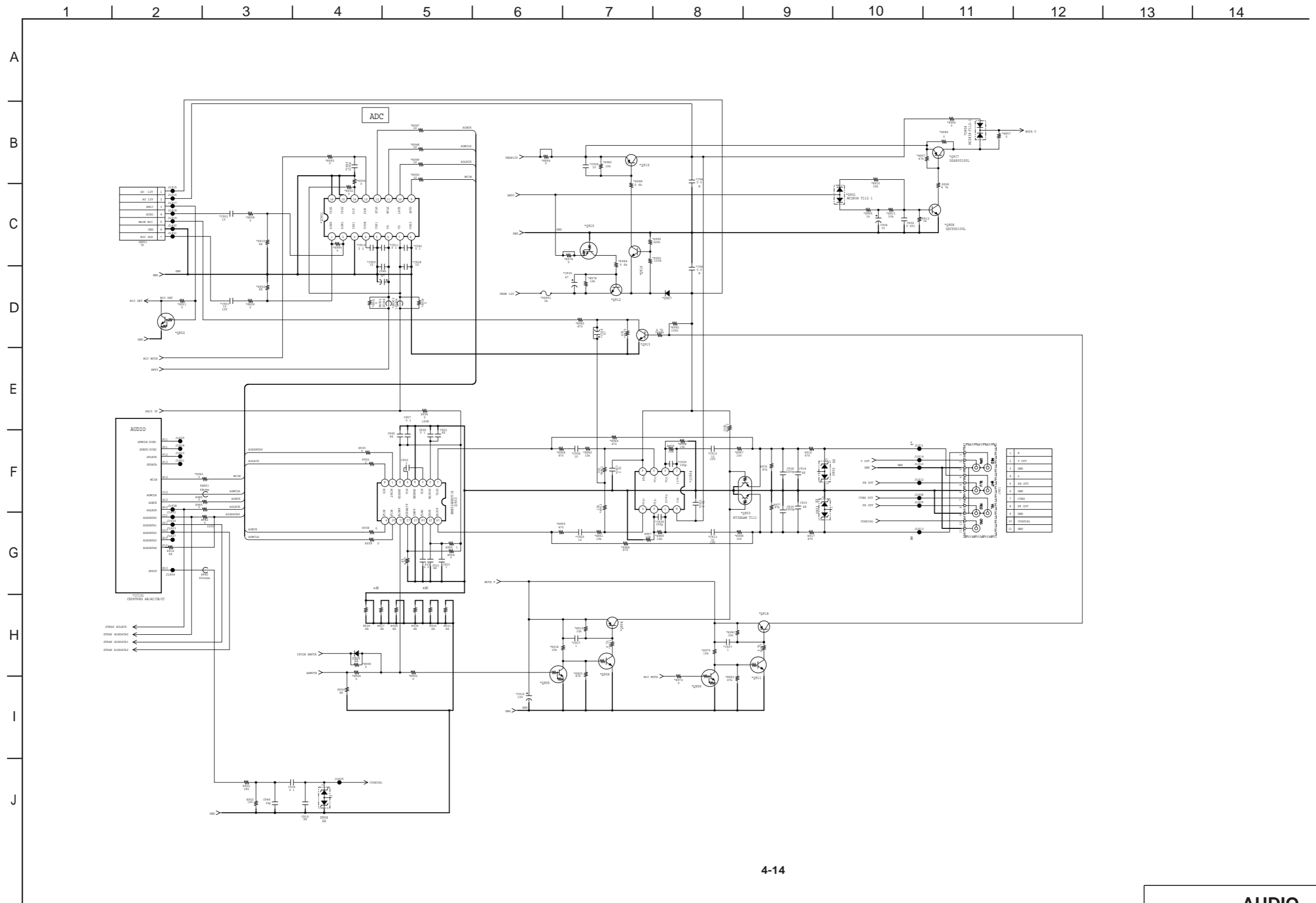

4-15. MB-139 BOARD (CXD9998G-AB/AC/CB/CC) SCHEMATIC DIAGRAM (10/17) • See page 5-4 for printed wiring board.

- Ref. No.: MB-139 board; 10,000 series

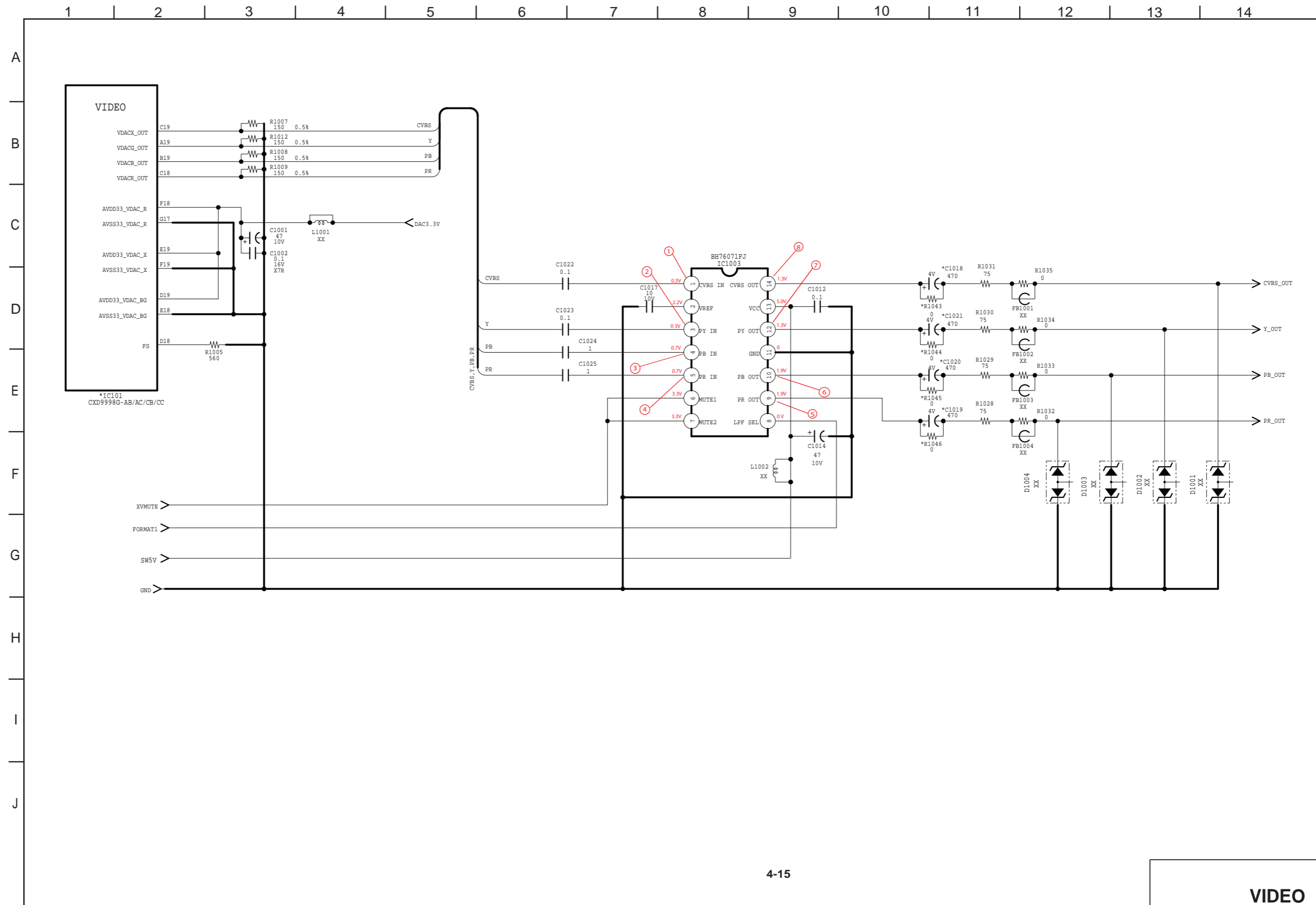

4-17. MB-139 BOARD (CXD9998G-AB/AC/CB/CC) SCHEMATIC DIAGRAM (12/17) • See page 5-4 for printed wiring board.

- Ref. No.: MB-139 board; 10,000 series

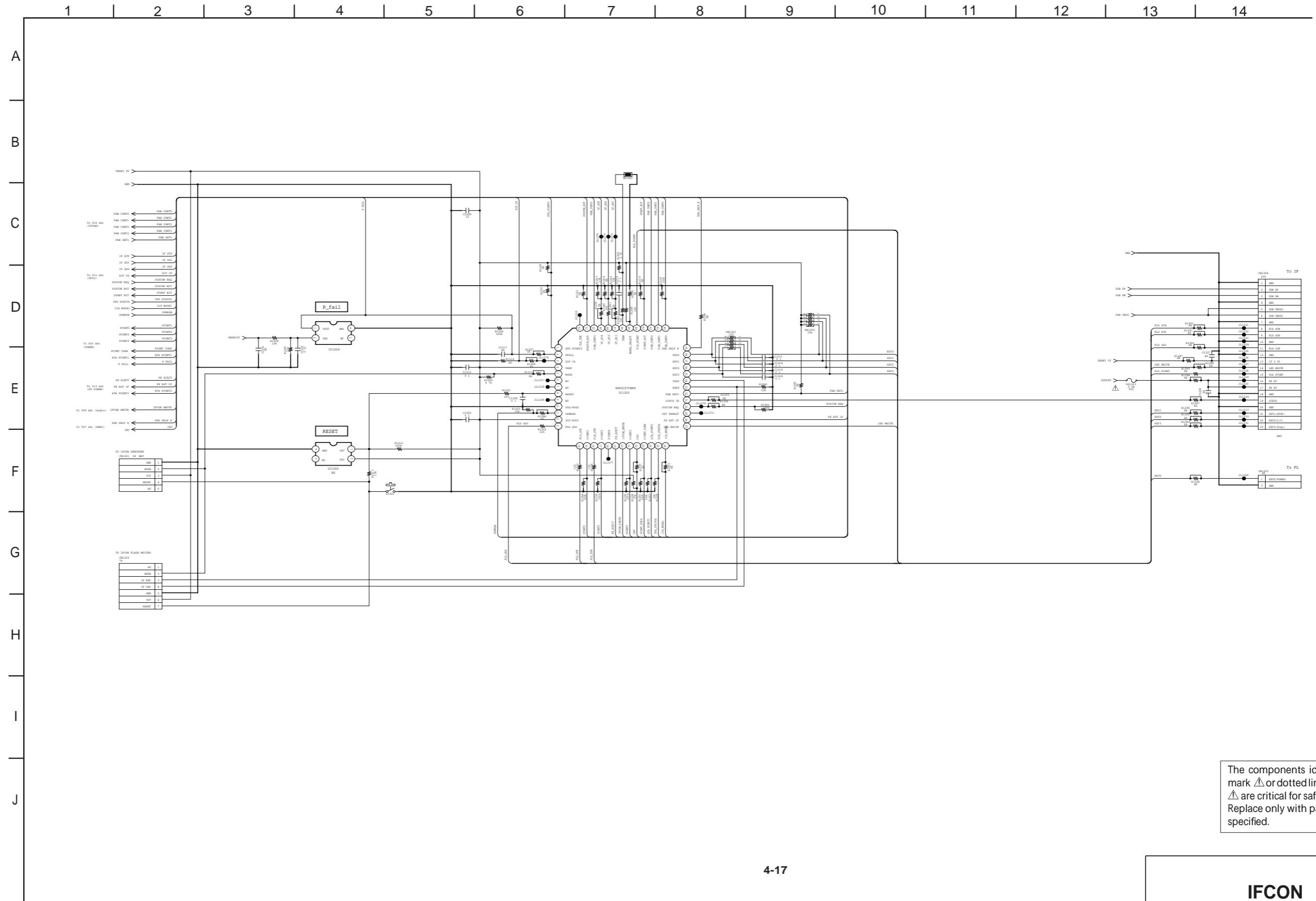

The components identified by mark \triangle or dotted line with mark \triangle are critical for safety. Replace only with part number specified.

4-18. MB-139 BOARD (CXD9998G-AB/AC/CB/CC) SCHEMATIC DIAGRAM (13/17) • See page 5-4 for printed wiring board.

- Ref. No.: MB-139 board; 10,000 series

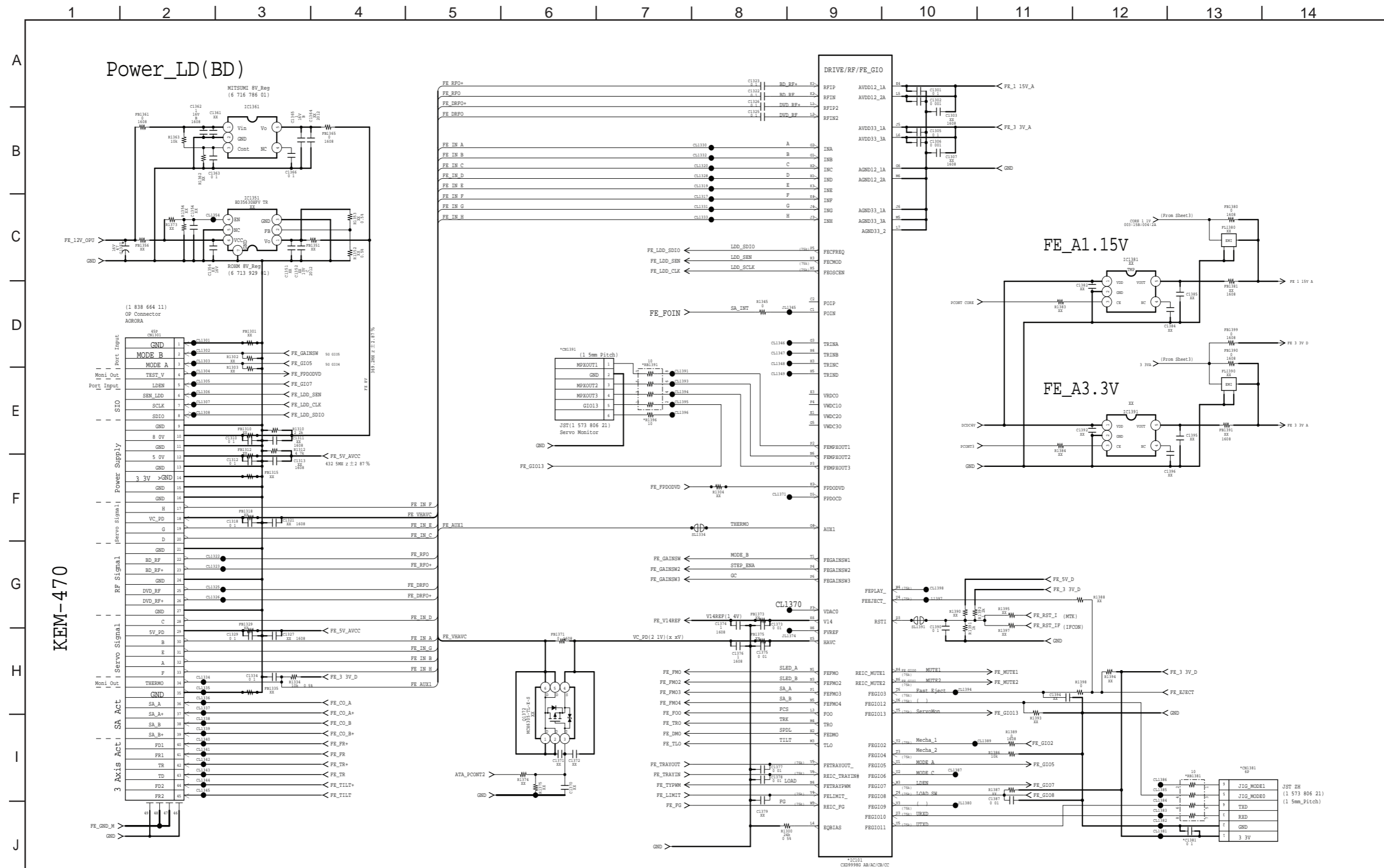

4-19. MB-139 BOARD (CXD9998G-AB/AC/CB/CC) SCHEMATIC DIAGRAM (14/17) • See page 5-4 for printed wiring board.

- Ref. No.: MB-139 board; 10,000 series

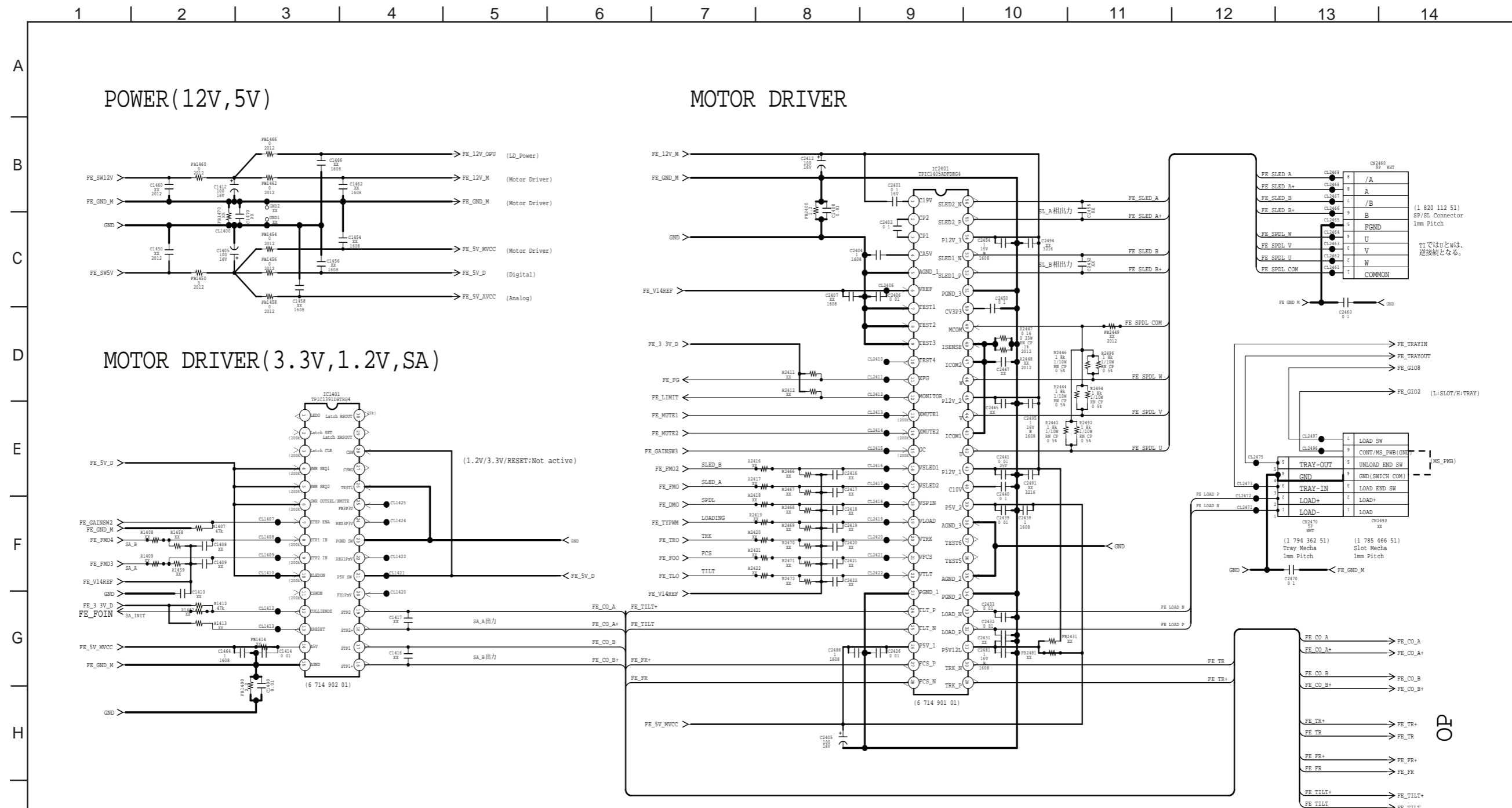

4-20. MB-139 BOARD (CXD9998G-AB/AC/CB/CC) SCHEMATIC DIAGRAM (15/17) • See page 5-4 for printed wiring board.

- Ref. No.: MB-139 board; 10,000 series

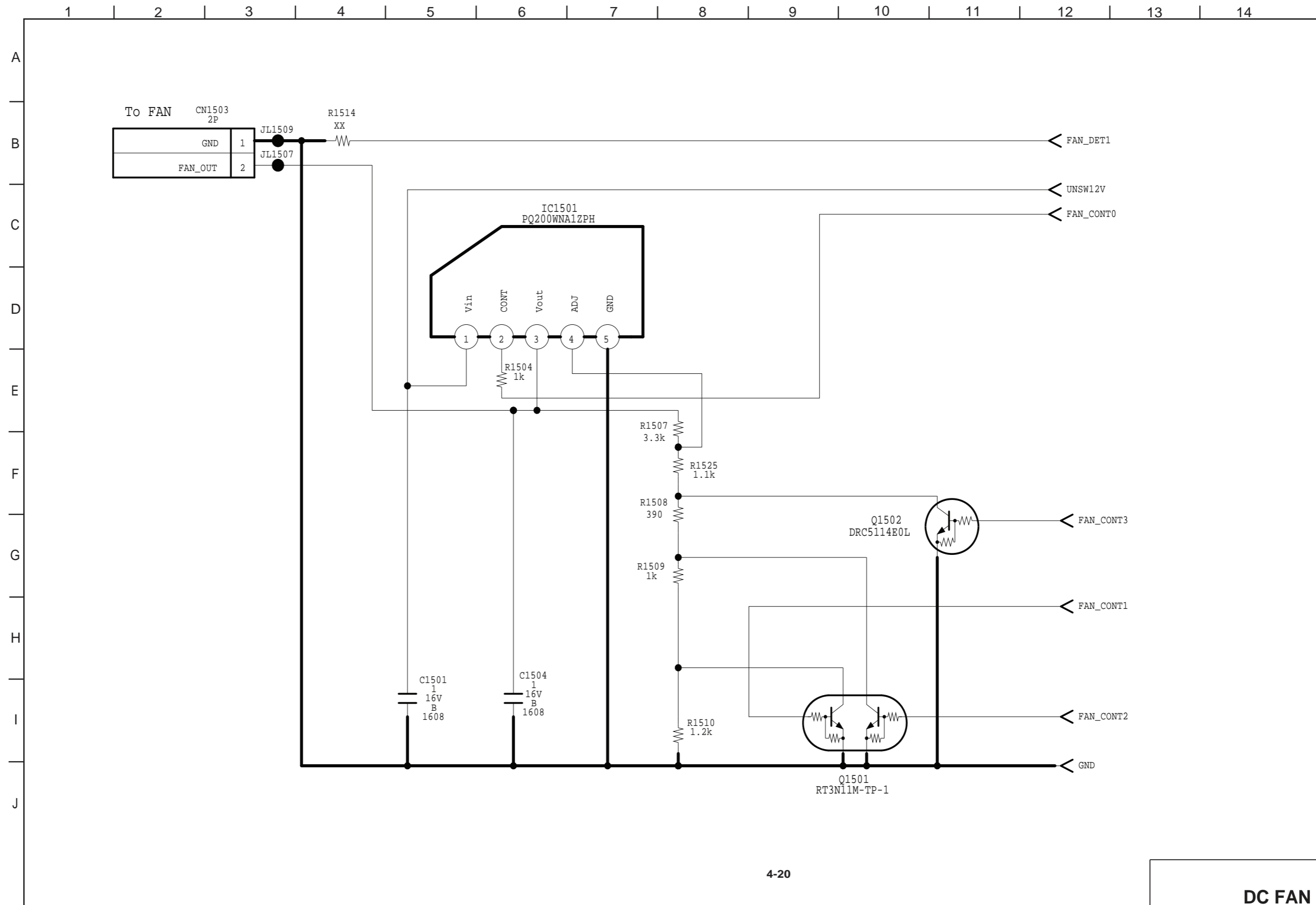

4-21. MB-139 BOARD (CXD9998G-AB/AC/CB/CC) SCHEMATIC DIAGRAM (16/17) • See page 5-4 for printed wiring board.

- Ref. No.: MB-139 board; 10,000 series

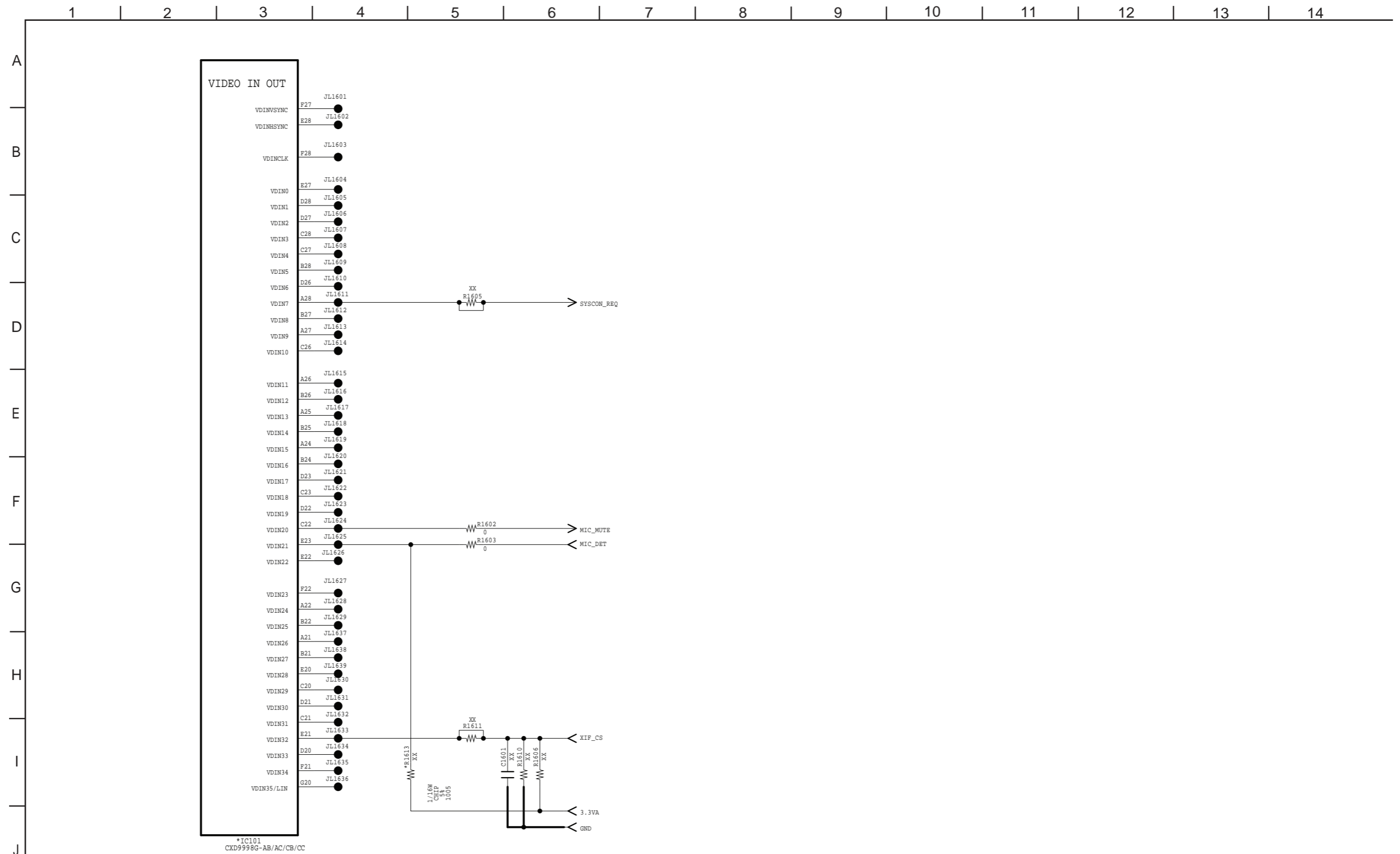

4-22. MB-139 BOARD (CXD9998G-AB/AC/CB/CC) SCHEMATIC DIAGRAM (17/17) • See page 5-4 for printed wiring board.

- Ref. No.: MB-139 board; 10,000 series

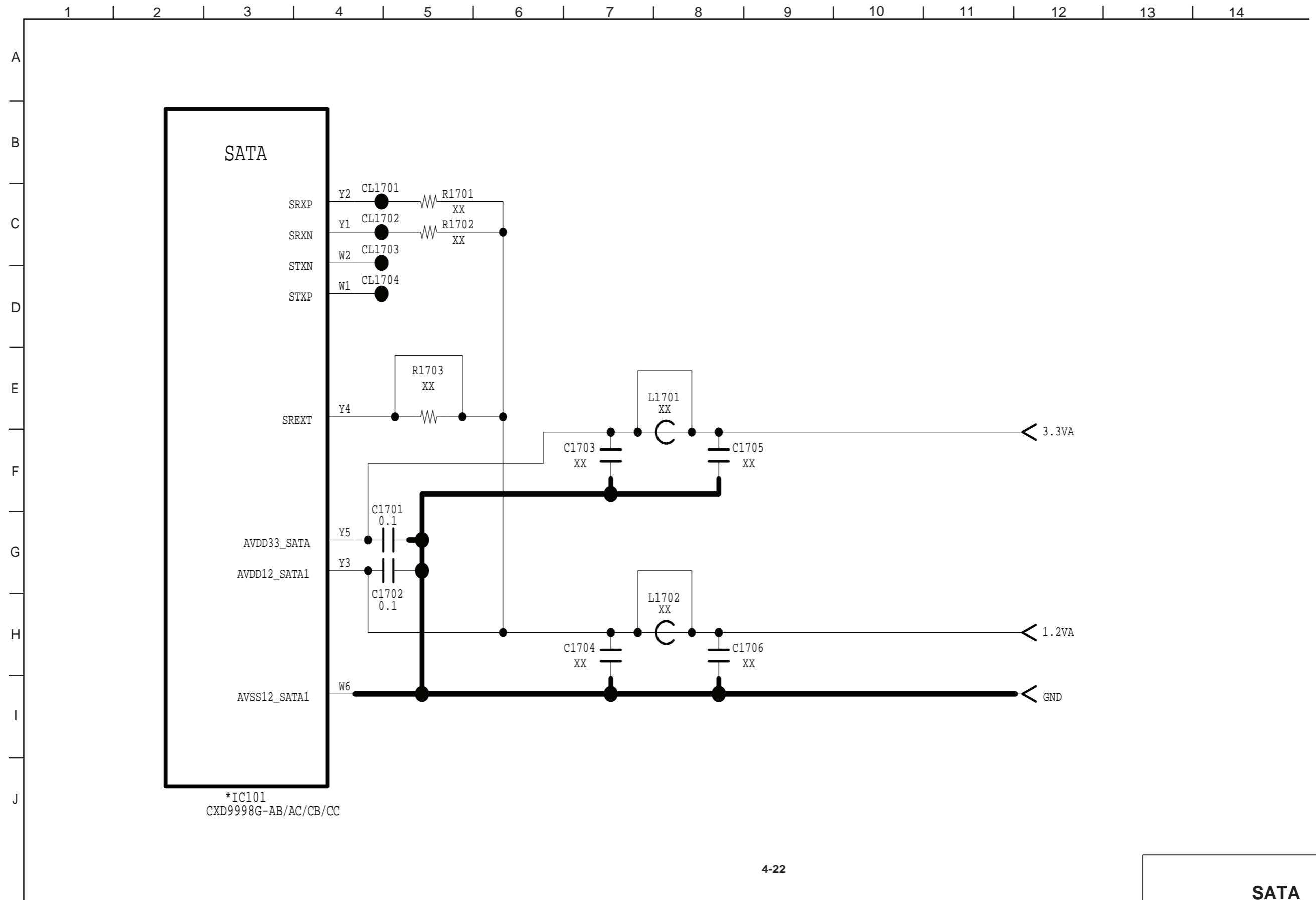

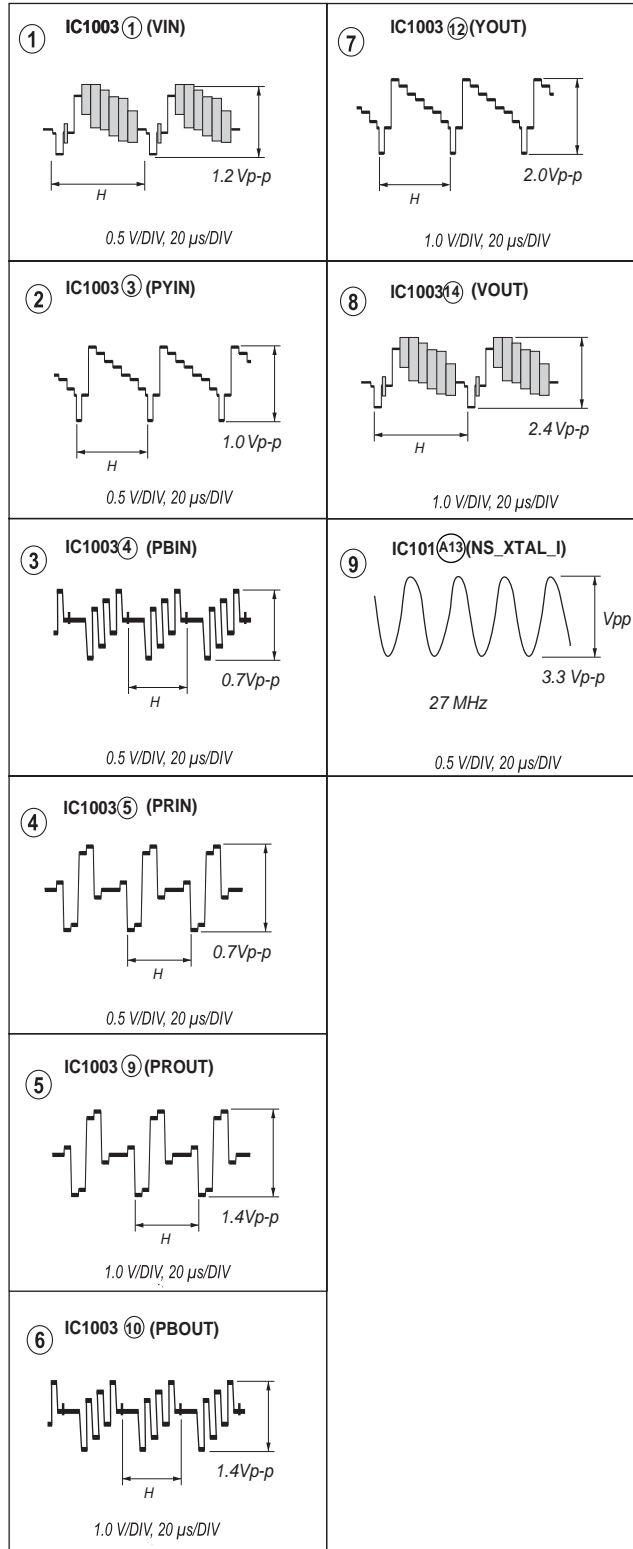

4-23. WAVEFORMS

MB-139 BOARD



SECTION 5 PRINTED WIRING BOARD

5-1. THIS NOTE IS COMMON FOR PRINTED WIRING BOARDS

-  : Uses unleaded solders.
-  : Pattern from the side which enables seeing.
(The other layers' patterns are not indicated)

Caution:

Pattern face side: Parts on the pattern face side seen from (SIDE B) the pattern face are indicated.
Parts face side: Parts on the parts face side seen from (SIDE A) the parts face are indicated.

- Through hole is omitted.
- There are few cases that the part printed on diagram isn't mounted in this model.
-  : panel designation
- Chip parts.

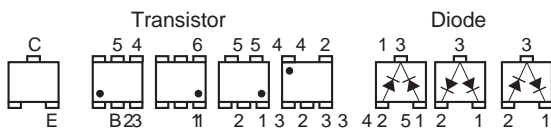

5-2. FL-203 (REAR) BOARD PRINTED WIRING BOARD

- Ref. No.: FL-203 board; 20,000 series -

- See page 2-5 for circuit boards location.

LF : Uses unleaded solder.

There are a few cases that the part isn't mounted in this model is printed on this diagram.

FL-203 BOARD (SIDE A)

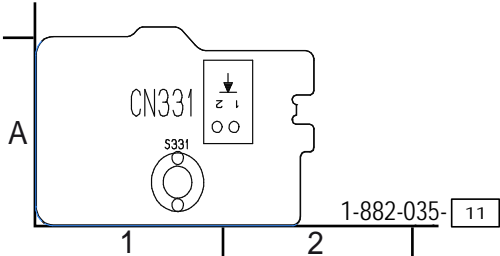

FL-203 BOARD (S DE A)

CN331 A-1

5-4. MB-139 BOARD (MAIN) PRINTED WIRING BOARD (SIDE A) • See page 2-5 for circuit boards location.
 - Ref. No.: MB-139 board; 10,000 series -

There are a few cases that the part isn't mounted in this model is printed on this diagram.

 : Uses unleaded solder.

MB-139 BOARD (SIDE A)

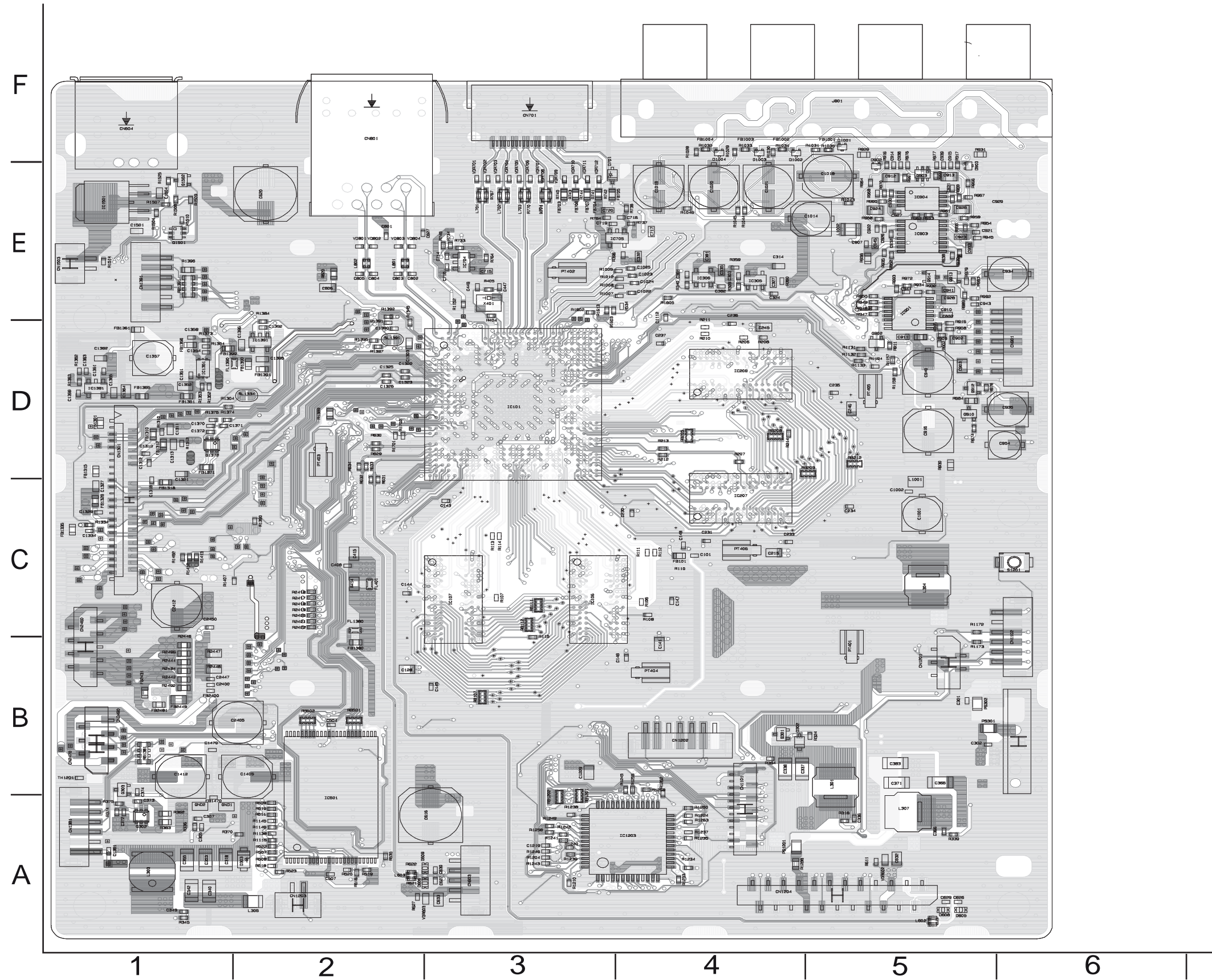

SECTION 6

IC PIN FUNCTION DESCRIPTION

MAIN SYSTEM CONTROL PIN FUNCTION (MB-139 BOARD IC 101 : CXD9998G-AB/AC/CB/CC)

Pin	Symbol	Type	Description
M9	DVCC10 K	Power	1.15 V digital power
V9	DVCC10 K	Power	1.15 V digital power
L10	DVCC10 K	Power	1.15 V digital power
N10	DVCC10 K	Power	1.15 V digital power
R10	DVCC10 K	Power	1.15 V digital power
U10	DVCC10 K	Power	1.15 V digital power
W10	DVCC10 K	Power	1.15 V digital power
K11	DVCC10 K	Power	1.15 V digital power
P11	DVCC10 K	Power	1.15 V digital power
T11	DVCC10 K	Power	1.15 V digital power
V11	DVCC10 K	Power	1.15 V digital power
L12	DVCC10 K	Power	1.15 V digital power
W12	DVCC10 K	Power	1.15 V digital power
K13	DVCC10 K	Power	1.15 V digital power
V13	DVCC10 K	Power	1.15 V digital power
L14	DVCC10 K	Power	1.15 V digital power
W14	DVCC10 K	Power	1.15 V digital power
K15	DVCC10 K	Power	1.15 V digital power
V15	DVCC10 K	Power	1.15 V digital power
L16	DVCC10 K	Power	1.15 V digital power
W16	DVCC10 K	Power	1.15 V digital power
K17	DVCC10 K	Power	1.15 V digital power
V17	DVCC10 K	Power	1.15 V digital power
L18	DVCC10 K	Power	1.15 V digital power
N18	DVCC10 K	Power	1.15 V digital power
R18	DVCC10 K	Power	1.15 V digital power
U18	DVCC10 K	Power	1.15 V digital power
W18	DVCC10 K	Power	1.15 V digital power
K19	DVCC10 K	Power	1.15 V digital power
M19	DVCC10 K	Power	1.15 V digital power
P19	DVCC10 K	Power	1.15 V digital power
T19	DVCC10 K	Power	1.15 V digital power
V19	DVCC10 K	Power	1.15 V digital power
N9, U9,	DGND	Ground	Digital ground
W9, K10,	DGND	Ground	Digital ground
M10, P10	DGND	Ground	Digital ground
T10, V10	DGND	Ground	Digital ground
AF10, L11	DGND	Ground	Digital ground
M11, N11	DGND	Ground	Digital ground
R11, U11	DGND	Ground	Digital ground
W11, AB11	DGND	Ground	Digital ground
K12, M12	DGND	Ground	Digital ground
N12, P12	DGND	Ground	Digital ground
R12, T12	DGND	Ground	Digital ground
U12, V12	DGND	Ground	Digital ground
AA12, L13	DGND	Ground	Digital ground
M13, N13	DGND	Ground	Digital ground
P13, R13	DGND	Ground	Digital ground
T13, U13	DGND	Ground	Digital ground
W13, K14	DGND	Ground	Digital ground
M14, N14	DGND	Ground	Digital ground
P14, R14	DGND	Ground	Digital ground
T14, U14	DGND	Ground	Digital ground
V14, AA14	DGND	Ground	Digital ground
AE14, L15	DGND	Ground	Digital ground
M15, N15	DGND	Ground	Digital ground
P15, R15	DGND	Ground	Digital ground
T15, U15	DGND	Ground	Digital ground
W15, K16	DGND	Ground	Digital ground
M16, N16	DGND	Ground	Digital ground
P16, R16	DGND	Ground	Digital ground
T16, U16	DGND	Ground	Digital ground
V16, AA16	DGND	Ground	Digital ground
L17, M17	DGND	Ground	Digital ground
N17, P17	DGND	Ground	Digital ground
R17, T17	DGND	Ground	Digital ground
U17, W17	DGND	Ground	Digital ground
AF17, K18	DGND	Ground	Digital ground
M18, P18	DGND	Ground	Digital ground
T18, V18	DGND	Ground	Digital ground
AA18, L19	DGND	Ground	Digital ground
N19, R19	DGND	Ground	Digital ground
U19, W19	DGND	Ground	Digital ground
AE20, L21	DGND	Ground	Digital ground
N21, R21	DGND	Ground	Digital ground
U21, W21	DGND	Ground	Digital ground

N25, V25	DGND	Ground	Digital ground
R26, AA26	DGND	Ground	Digital ground
AF26	DGND	Ground	Digital ground
N8	DVCC33 IO	Power	3.3 V digital IO power
P8	DVCC33 IO	Power	3.3 V digital IO power
T8	DVCC33 IO	Power	3.3 V digital IO power
Y8	DCC33 IO 2	Power	3.3 V digital IO power
AA8	DCC33 IO 2	Power	3.3 V digital IO power
J18	DVCC33 IO 3	Power	3.3 V digital IO power
J19	DVCC33 IO 3	Power	3.3 V digital IO power
J13	DVCC33 IO 5	Power	3.3 V digital IO power
J14	DVCC33 IO 5	Power	3.3 V digital IO power
H21	DVCC33 IO S TB	Power	3.3 V digital IO power for Stand-By Module
J21	DVCC33 IO S TB	Power	3.3 V digital IO power for Stand-By Module
AE10	DVCC18 IO 1	Power	1.8 V / 1.5 V digital IO power
AA11	DVCC18 IO 1	Power	1.8 V / 1.5 V digital IO power
AA13	DVCC18 IO 1	Power	1.8 V / 1.5 V digital IO power
AF13	DVCC18 IO 1	Power	1.8 V / 1.5 V digital IO power
AF14	DVCC18 IO 1	Power	1.8 V / 1.5 V digital IO power
AA15	DVCC18 IO 1	Power	1.8 V / 1.5 V digital IO power
AA17	DVCC18 IO 1	Power	1.8 V / 1.5 V digital IO power
AE17	DVCC18 IO 1	Power	1.8 V / 1.5 V digital IO power
AA19	DVCC18 IO 1	Power	1.8 V / 1.5 V digital IO power
Y20	DVCC18 IO 1	Power	1.8 V / 1.5 V digital IO power
AF20	DVCC18 IO 1	Power	1.8 V / 1.5 V digital IO power
M21	DVCC18 IO 1	Power	1.8 V / 1.5 V digital IO power
P21	DVCC18 IO 1	Power	1.8 V / 1.5 V digital IO power
T21	DVCC18 IO 1	Power	1.8 V / 1.5 V digital IO power
V21	DVCC18 IO 1	Power	1.8 V / 1.5 V digital IO power
R25	DVCC18 IO 1	Power	1.8 V / 1.5 V digital IO power
AA25	DVCC18 IO 1	Power	1.8 V / 1.5 V digital IO power
P26	DVCC18 IO 1	Power	1.8 V / 1.5 V digital IO power
V26	DVCC18 IO 1	Power	1.8 V / 1.5 V digital IO power
AG26	DVCC18 IO 1	Power	1.8 V / 1.5 V digital IO power
AE23	AVDD12 MEM PLL	Power	1.2V Analog Power for MEMPLL
AD23	AVSS12 MEM PLL	Ground	Analog Ground for MEMPLL
AF24	TN_MEMPLL	Analog	Test Pin
AE24	TP_MEMPLL	Analog	Test Pin
K21	AVDD10 LDO	Power	Internal standby power
E15	AVDD12 27MP LL	Power	1.2V Analog Power for PLL
G15	AVDD12 APLL	Power	1.2V Analog Power for APLL
F15	AVDD12 DMP LL	Power	1.2V Analog Power for DMPLL
J24	AVDD33 LDO	Power	3.3V power for standby
C15	AVDD33 XTAL	Power	3.3V Analog Power for XTAL
E14	AVSS12 27MP LL	Ground	Analog Ground for PLL
G14	AVSS12 APLL	Ground	Analog Ground for APLL
F14	AVSS12 DMPL L	Ground	Analog Ground for DMPLL
H22	AVSS33 LDO	Ground	Analog ground for standby
D15	AVSS33 XTAL	Ground	Analog ground for XTAL
A13	NS_XTALI	O	27MHz Crystal Out
B13	NS_XTALO	I	27MHz Crystal In
D14	TN_PLLG	Analog	Test Pin
C14	TP_PLLG	Analog	Test Pin
D10	AMUTE	I/O	NC
A12	AOBCK	I/O	Audio out bit clock
B12	AOLRCK	I/O	Audio out left-right clock
C12	AOMCLK	I/O	Audio out master clock
C11	AOSDATA0	I/O	Audio out serial data 0
D11	AOSDATA1	I/O	NC
D12	AOSDATA2	I/O	NC
E10	AOSDATA3	I/O	NC
F10	AOSDATA4	I/O	NC
E12	MCIN	I/O	Microphone in/Line in
G11	SPBCK	I/O	NC
F13	SPDATA	I/O	NC
E13	SPDIF	I/O	SPDIF Out
F12	SPLRCK	I/O	NC
F11	SPMCLK	I/O	NC
D19	AVDD33 VDA C BG	Power	3.3V Analog Power
F18	AVDD33 VDA C R	Power	3.3V Analog Power
E19	AVDD33 VDA C X	Power	3.3V Analog Power
E18	AVSS33 VDAC BG	Ground	Analog Ground
G17	AVSS33 VDAC R	Ground	Analog Ground
F19	AVSS33 VDAC X	Ground	Analog Ground
D18	FS	Analog	DAC full scale
B19	VDACB_OUT	Analog	DAC output
A19	VDACG_OUT	Analog	DAC output
C18	VDACR_OUT	Analog	DAC output
C19	VDACX_OUT	Analog	DAC output
H24	GPIO8 / VOUTCLK1	I/O	NC
F24	ETTXER / VOUTD0	I/O	NC
E26	ETRXER / VOUTD1	I/O	NC
G23	ETTXD0 / VOUTD10	I/O	NC
H23	ETTXD1 / VOUTD11	I/O	NC
J23	ETTXD2 / VOUTD12	I/O	NC
H26	ETTXD3 / VOUTD13	I/O	NC

H25	ETTXEN / VOUTD14	I/O	NC
J27	ETCOL / VOUTD15	I/O	NC
F26	ETCRS / VOUTD2	I/O	NC
E25	ETRXDV / VOUTD3	I/O	NC
F25	ETRXD0 / VOUTD4	I/O	NC
G27	ETRXD1 / VOUTD5	I/O	NC
G28	ETRXD2 / VOUTD6	I/O	NC
G26	ETRXCLK / VOUTD7	I/O	NC
G25	ETRXD3 / VOUTD8	I/O	NC
G24	ETTXCLK / VOUTD9	I/O	NC
J26	ETMDIO / VOUTHSYNC	I/O	NC
J28	ETMDC / VOUTVSYNC	I/O	NC
D16	AVDD12_HDMI_TX	Power	1.2V Analog Power
E16	AVDD12_HDMI_TX	Power	1.2V Analog Power
C17	AVDD33_HDMI_TX	Power	3.3V Analog Power
D17	AVDD33_HDMI_TX	Power	3.3V Analog Power
F16	AVSS12_HDMI_TX	Ground	Analog Ground
G16	AVSS12_HDMI_TX	Ground	Analog Ground
E17	AVSS33_HDMI_TX	Ground	Analog Ground
F17	AVSS33_HDMI_TX	Ground	Analog Ground
A16	CH0_M	Analog	HDMI TX data 0 differential pair (M) / MB140 (NC)
B16	CH0_P	Analog	HDMI TX data 0 differential pair (P) / MB140 (NC)
A15	CH1_M	Analog	HDMI TX data 1 differential pair (M) / MB140 (NC)
B15	CH1_P	Analog	HDMI TX data 1 differential pair (P) / MB140 (NC)
A14	CH2_M	Analog	HDMI TX data 2 differential pair (M) / MB140 (NC)
B14	CH2_P	Analog	HDMI TX data 2 differential pair (P) / MB140 (NC)
A17	CLK_M	Analog	HDMI TX clock differential pair (M) / MB140 (NC)
B17	CLK_P	Analog	HDMI TX clock differential pair (P) / MB140 (NC)
A18	EXT_CAP	Analog	HDMI AIO
B18	EXT_RES	Analog	HDMI reference voltage
AF5	SFCK	I/O	NC
AH5	SFCS	I/O	USB_VBUS_PCONT, USB Power Control
AG5	SFDI	I/O	FORMAT1, SD/HD Control
AH4	SFDO	I/O	NC
AF4	NFALE	I/O	NAND Flash address latch enable
AH2	NFCEN	I/O	NAND Flash chip enable
AD5	NFCEN2	I/O	NC
AG3	NFCLE	I/O	NAND Flash command latch enable
AG2	NFD0	I/O	NAND Flash Data input/output bit0
AH1	NFD1	I/O	NAND Flash Data input/output bit1
AF3	NFD2	I/O	NAND Flash Data input/output bit2
AG1	NFD3	I/O	NAND Flash Data input/output bit3
AF2	NFD4	I/O	NAND Flash Data input/output bit4
AF1	NFD5	I/O	NAND Flash Data input/output bit5
AE2	NFD6	I/O	NAND Flash Data input/output bit6
AE1	NFD7	I/O	NAND Flash Data input/output bit7
AE3	NFRBN	I/O	NAND Flash ready/busy
AE4	NFRBN2	I/O	NC
AD4	NFREN	I/O	NAND Flash read enable
AG4	NFWEN	I/O	NAND Flash write enable
AD13	RA0	O	Memory address bit 0
AE19	RA1	O	Memory address bit 1
AF16	RA2	O	Memory address bit 2
AH14	RA3	O	Memory address bit 3
AD18	RA4	O	Memory address bit 4
AD15	RA5	O	Memory address bit 5
AC17	RA6	O	Memory address bit 6
AE16	RA7	O	Memory address bit 7
AH16	RA8	O	Memory address bit 8
AF15	RA9	O	Memory address bit 9
AH17	RA10	O	Memory address bit 10
AD17	RA11	O	Memory address bit 11
AC18	RA12	O	Memory address bit 12
AD16	RA13	O	Memory address bit 13
AG14	RBA0	O	Memory bank address bit 0
AD19	RBA1	O	Memory bank address bit 1
AC15	RBA2	O	Memory bank address bit 2
AD14	RCAS	O	Memory column address strobe
AG16	RCKE	O	Memory clock enable
AG24	RCLK0	O	Memory clock 0 positive
AH24	RCLK0	O	Memory clock 0 negative
AG13	RCLK1	O	Memory clock 1 positive
AH13	RCLK1	O	Memory clock 1 negative
AE15	RCS	O	Memory chip select
AG17	RDQ0	I/O	Memory data bit 0
AF18	RDQ1	I/O	Memory data bit 1
AE18	RDQ2	I/O	Memory data bit 2
AF19	RDQ3	I/O	Memory data bit 3
AC22	RDQ4	I/O	Memory data bit 4
AF23	RDQ5	I/O	Memory data bit 5
AF22	RDQ6	I/O	Memory data bit 6
AG22	RDQ7	I/O	Memory data bit 7
AH19	RDQ8	I/O	Memory data bit 8
AG19	RDQ9	I/O	Memory data bit 9
AC20	RDQ10	I/O	Memory data bit 10
AD20	RDQ11	I/O	Memory data bit 11

AE22	RDQ12	I/O	Memory data bit 12
AH22	RDQ13	I/O	Memory data bit 13
AD22	RDQ14	I/O	Memory data bit 14
AF21	RDQ15	I/O	Memory data bit 15
AG7	RDQ16	I/O	Memory data bit 16
AH7	RDQ17	I/O	Memory data bit 17
AH8	RDQ18	I/O	Memory data bit 18
AG8	RDQ19	I/O	Memory data bit 19
AF12	RDQ20	I/O	Memory data bit 20
AE12	RDQ21	I/O	Memory data bit 21
AC12	RDQ22	I/O	Memory data bit 22
AD12	RDQ23	I/O	Memory data bit 23
AE8	RDQ24	I/O	Memory data bit 24
AF8	RDQ25	I/O	Memory data bit 25
AE9	RDQ26	I/O	Memory data bit 26
AF9	RDQ27	I/O	Memory data bit 27
AH11	RDQ28	I/O	Memory data bit 28
AG11	RDQ29	I/O	Memory data bit 29
AF11	RDQ30	I/O	Memory data bit 30
AE11	RDQ31	I/O	Memory data bit 31
AE21	RDQM0	O	Memory data mask bit 0
AD21	RDQM1	O	Memory data mask bit 1
AD10	RDQM2	O	Memory data mask bit 2
AD9	RDQM3	O	Memory data mask bit 3
AG20	RDQS0	I/O	Memory positive data strobe bit 0
AH20	RDQS0	I/O	Memory negative data strobe bit 0
AH21	RDQS1	I/O	Memory positive data strobe bit 1
AG21	RDQS1	I/O	Memory negative data strobe bit 1
AG9	RDQS2	I/O	Memory positive data strobe bit 2
AH9	RDQS2	I/O	Memory negative data strobe bit 2
AH10	RDQS3	I/O	Memory positive data strobe bit 3
AG10	RDQS3	I/O	Memory negative data strobe bit 3
AC14	RODT	O	Memory on die termination enable
AC13	RRAS	O	Memory row address strobe
AB12	RVREF_1	I	Memory VREF
AA20	RVREF_2	I	Memory VREF
AE13	RWE	O	Memory write enable
AC16	RRESET	O	Memory reset
AE27	RA0_B	O	Memory address bit 0
U24	RA1_B	O	Memory address bit 1
W28	RA2_B	O	Memory address bit 2
AA27	RA3_B	O	Memory address bit 3
V24	RA4_B	O	Memory address bit 4
AA28	RA5_B	O	Memory address bit 5
W24	RA6_B	O	Memory address bit 6
W27	RA7_B	O	Memory address bit 7
Y24	RA8_B	O	Memory address bit 8
W26	RA9_B	O	Memory address bit 9
V28	RA10_B	O	Memory address bit 10
V23	RA11_B	O	Memory address bit 11
U23	RA12_B	O	Memory address bit 12
Y25	RA13_B	O	Memory address bit 13
AB26	RBA0_B	O	Memory bank address bit 0
T24	RBA1_B	O	Memory bank address bit 1
W25	RBA2_B	O	Memory bank address bit 2
AC26	RCAS_B	O	Memory column address strobe
V27	RCKE_B	O	Memory clock enable
L27	RCLK0_B	O	Memory clock 0 positive
L28	RCLK0_B	O	Memory clock 0 negative
AB27	RCLK1_B	O	Memory clock 1 positive
AB28	RCLK1_B	O	Memory clock 1 negative
AB25	RCS_B	O	Memory chip select
T25	RDQ0_B	I/O	Memory data bit 0
T26	RDQ1_B	I/O	Memory data bit 1
U26	RDQ2_B	I/O	Memory data bit 2
U25	RDQ3_B	I/O	Memory data bit 3
M26	RDQ4_B	I/O	Memory data bit 4
M25	RDQ5_B	I/O	Memory data bit 5
N28	RDQ6_B	I/O	Memory data bit 6
N27	RDQ7_B	I/O	Memory data bit 7
P23	RDQ8_B	I/O	Memory data bit 8
T28	RDQ9_B	I/O	Memory data bit 9
T27	RDQ10_B	I/O	Memory data bit 10
T23	RDQ11_B	I/O	Memory data bit 11
N26	RDQ12_B	I/O	Memory data bit 12
P24	RDQ13_B	I/O	Memory data bit 13
N23	RDQ14_B	I/O	Memory data bit 14
N24	RDQ15_B	I/O	Memory data bit 15
AF25	RDQ16_B	I/O	Memory data bit 16
AG25	RDQ17_B	I/O	Memory data bit 17
AH25	RDQ18_B	I/O	Memory data bit 18
AH26	RDQ19_B	I/O	Memory data bit 19
AA24	RDQ20_B	I/O	Memory data bit 20
AB24	RDQ21_B	I/O	Memory data bit 21
AA23	RDQ22_B	I/O	Memory data bit 22
AB23	RDQ23_B	I/O	Memory data bit 23

AD25	RDQ24_B	I/O	Memory data bit 24
AE25	RDQ25_B	I/O	Memory data bit 25
AH27	RDQ26_B	I/O	Memory data bit 26
AH28	RDQ27_B	I/O	Memory data bit 27
AC25	RDQ28_B	I/O	Memory data bit 28
AD24	RDQ29_B	I/O	Memory data bit 29
AC24	RDQ30_B	I/O	Memory data bit 30
AC23	RDQ31_B	I/O	Memory data bit 31
P25	RDQM0_B	O	Memory data mask bit 0
R24	RDQM1_B	O	Memory data mask bit 1
AD26	RDQM2_B	O	Memory data mask bit 2
AE26	RDQM3_B	O	Memory data mask bit 3
R27	RDQS0_B	I/O	Memory positive data strobe bit 0
R28	RDQS0_B	I/O	Memory negative data strobe bit 0
P28	RDQS1_B	I/O	Memory positive data strobe bit 1
P27	RDQS1_B	I/O	Memory negative data strobe bit 1
AG27	RDQS2_B	I/O	Memory positive data strobe bit 2
AG28	RDQS2_B	I/O	Memory negative data strobe bit 2
AF28	RDQS3_B	I/O	Memory positive data strobe bit 3
AF27	RDQS3_B	I/O	Memory negative data strobe bit 3
AD27	RODT_B	O	Memory on die termination enable
AD28	RRAS_B	O	Memory row address strobe
AA21	RVREF_3	I	Memory VREF
R23	RVREF_4	I	Memory VREF
AE28	RWE_B	O	Memory write enable
Y26	RRESET_B	O	Memory reset
AD7	TCK	I/O	JTAG ICE clock / JTAG boundary scan clock
AD8	TDI	I/O	JTAG ICE data in / JTAG boundary scan data in
AF6	TDO	I/O	JTAG ICE data out / JTAG boundary scan data out
AE7	TMS	I/O	JTAG ICE mode select / JTAG boundary mode select
AF7	TRST	I/O	JTAG ICE reset
AB3	AVDD12_USB_1P_1	Power	1.2V Analog power for USB
AA3	AVDD33_USB_1P_1	Power	3.3V Analog power for USB
AB6	AVSS12_USB_1P_1	Ground	Analog ground for USB
AA5	AVSS33_USB_1P_1	Ground	Analog ground for USB
AA6	AVSS33_USB_1P_1	Ground	Analog ground for USB
AB1	USB_1P_DM	Analog	USB port3 differential serial data bus (minus)
AB2	USB_1P_DP	Analog	USB port3 differential serial data bus (plus)
AC3	USB_1P_VRT	Analog	USB reference resistor
AC4	AVDD12_USB_2P_1A	Power	1.2V Analog power for USB
AA4	AVDD33_USB_2P_2	Power	3.3V Analog power for USB
AB5	AVSS12_USB_2P_1A	Ground	Analog ground for USB
AD1	USB_2P_DM0	Analog	USB port1 differential serial data bus (minus)
AC1	USB_2P_DM1	Analog	USB port2 differential serial data bus (minus)
AD2	USB_2P_DP0	Analog	USB port1 differential serial data bus (plus)
AC2	USB_2P_DP1	Analog	USB port2 differential serial data bus (plus)
AD3	USB_2P_VRT	Analog	USB reference resistor
AC9	EFPWRQ	Power	2.5V power for E-fuse programming
F5	AVDD33_REC	Power	HVGA analog power
D4	AVDD33_LD	Power	TX0 analog power
C5	AVDD33_COM	Power	PLL/BG 3.3V analog power
F6	AVSS33_REC	Ground	HVGA analog ground
C4	AVSS33_LD	Ground	TX0 analog ground
D5	AVSS33_COM	Ground	PLL/BG 3.3V analog ground
E5	AVDD12_COM	Power	PLL 1.2V analog power
E6	AVDD12_REC	Power	ADC analog power
F7	AVSS12_COM	Ground	PLL 1.2V analog ground
G7	AVSS12_REC	Ground	ADC analog ground
A2	TXVP_0	Analog	Ethernet TD+
B4	TXVP_1	Analog	Ethernet RD+
B3	TXVN_0	Analog	Ethernet TD
A4	TXVN_1	Analog	Ethernet RD
D6	REXT	Analog	External reference resistor
A5	TANA_0	Analog	Ethernet analog test pin #0
B5	TANA_1	Analog	Ethernet analog test pin #1
J6	AGND33_1A	Analog Ground	Analog Ground
L7	AGND33_2	Analog Ground	Analog Ground
M	AGND33_3A	Analog Ground	Analog Ground
G6	AGND12_1A	Analog Ground	Analog Ground
M6	AGND12_2A	Analog Ground	Analog Ground
G4	AUX1 Analog	I/O	Auxiliary Input
E4	AVDD12_1A	Analog Power(1.2V)	Power Pin
L5	AVDD12_2A	Analog Power(1.2V)	Power Pin
J5	AVDD33_1A	Analog Power(3.3V)	Power Pin
L6	AVDD33_3A	Analog Power(3.3V)	Power Pin
P5	FECFREQ	3.3V LVTTTL I/O,5V-tolerance, Slow slew,2, 4, 6, 8mA PDR, 75K pull-up	Frequency selection signal output, or LDD serial interface data or I2C SDA. The pin is spike-free at power-on stage.
R3	FECMOD	3.3V LVTTTL I/O,5V-tolerance, Slow slew,2, 4, 6, 8mA PDR, 75K pulldown	High frequency modulation mode selection signal output, or LDD serial interface command enable. The pin is spike-free at power-on stage.
N2	FEDMO	Analog Output	Disk motor control output. DAC output.
U4	FEEJECT_	3.3V LVTTTL I/O,5V-tolerance, 6 mA PDR,75K pull-up	Eject/stop key input, active low. The pin is spike-free at poweron stage.
L4	EQBIAS	Analog Output	External Bias Connect on for Circuits

W5	FEFG	3.3V LVTTTL I/O,5V-tolerance, 6 mA PDR,75K pull-up	Motor Hall sensor input. The pin is spike-free at power-on stage.
N1	FEFMO	Analog Output	Feed motor 1 control. DAC output.
N3	FEFMO2	Analog Output	Feed motor 2 control. DAC output.
P1	FEFMO3	Analog I/O	Feed motor 3 control. DAC output. Alternative Function : Auxiliary servo input
N5	FEFMO4	Analog I/O	Feed motor 4 control. DAC output. Alternative Function : Auxiliary servo input
C1	FOIN	Analog Input	Input of Focusing Signal (Negative) Alternative Function : Auxiliary servo input
C2	FOIP	Analog Input	Input of Focusing Signal (Positive) Alternative Function : Auxiliary servo input
L3	FOO	Analog Output	Focus servo output. PDM output of focus servo compensator.
D1	FPDOCD	Analog Input	Laser Power Monitor Input for CD APC / Differential negative input
E2	FPDODVD	Analog Input	Laser Power Monitor Input for DVD APC / Differential positive input
T1	FEGAINSW1	Analog Output	Read gain switch. 1
P4	FEGAINSW2	Analog Output	Read gain switch 2.
P6	FEGAINSW3	Analog Output	Read gain switch 3.
R4	FEGIO0	3.3V LVTTTL I/O,5V-tolerance, 2,4,6,8 mA PDR,75K pulldown	LDD serial interface data. The pin is spike-free at power-on stage. The pin is not allowed to pull-up in circuit layout. FE_MUTE1
R6	FEGIO1	3.3V LVTTTL I/O,5V-tolerance, 2,4,6,8 mA PDR,75K pulldown	LDD serial interface CLK. The pin is spike-free at power-on stage. The pin is not allowed to pull-up in circuit layout. FE_MUTE2
U3	FEGIO10	3.3V LVTTTL I/O,5V-tolerance, 2,4,6,8 mA PDR,75K pull-up	PC RS232 serial receive data. The pin is spike-free at poweron stage URXD
U5	FEGIO11	3.3V LVTTTL I/O,5V-tolerance, 2,4,6,8 mA PDR,75K pull-up	PC RS232 serial transmit data. The pin is spike-free at poweron stage. UTXD
U6	FEGIO12	3.3V LVTTTL I/O,5V-tolerance, 2,4,6,8 mA PDR,75K pull-up	High speed serial output port. (CLOCK) The pin is spike-free at power-on stage.
T5	FEGIO13	3.3V LVTTTL I/O,5V-tolerance, 2,4,6,8 mA PDR,75K pull-up	High speed serial output port (Data) The pin is spike-free at power-on stage.
T2	FEGIO2	3.3V LVTTTL I/O,5V-tolerance, 2,4,6,8 mA PDR,75K pull-up	General IO. The pin is spike-free at power-on stage.
T6	FEGIO3	3.3V LVTTTL I/O,5V-tolerance, 2,4,6,8 mA PDR,75K pull-up	LED Control Output. Initial 0 Output. The pin is spike-free at power-on stage. FE_EJECT
T3	FEGIO4	Analog Output	Read/Write gain switch 6
U1	FEGIO5	Analog Output	Read/Write gain switch 7
U2	FEGIO6	Analog Output	Read/Write gain switch 8. The pin is not allowed to pull-up in circuit layout.
W3	FEGIO7	3.3V LVTTTL I/O,5V-tolerance, 2,4,6,8 mA PDR,75K pulldown	General IO. The pin is spike-free at power-on stage. The pin is not allowed to pull-up in circuit layout.
T4	FEGIO8	3.3V LVTTTL I/O,5V-tolerance, 2,4,6,8 mA PDR,75K pull-up	General IO The pin is spike-free at power-on stage.
V3	FEGIO9	3.3V LVTTTL I/O,5V-tolerance, 2,4,6,8 mA PDR,75K pulldown	General IO. The pin is spike-free at power-on stage.
K5	HAVC	Analog Output	Decoupling Pin for Reference Voltage of Main and Sub Beams
G2	INA	Analog Input	Input of Main Beam Signal (A)
G1	INB	Analog Input	Input of Main Beam Signal (B)
H2	INC	Analog Input	Input of Main Beam Signal (C)
H1	IND	Analog Input	Input of Main Beam Signal (D)
K3	INE	Analog Input	Input of Sub-Beam Signal (E)
K4	INF	Analog Input	Input of Sub-Beam Signal (F)
J4	ING	Analog Input	Input of Sub-Beam Signal (G)
J3	INH	Analog Input	Input of Sub-Beam Signal (H)
V4	FELIMIT_	3.3V LVTTTL I/O,5V-tolerance, 6 Ma,75k pull-up	Sledge Inner Limit Input, Active Low. The pin is spike-free at power-on stage.
P2	FEMPXOUT1	Analog Output	Multiplexer Output 1 for Signal Monitoring. The pin is not allowed to pull-up in circuit layout.
N6	FEMPXOUT2	Analog Output	Multiplexer Output 2 for Signal Monitoring. The pin is not allowed to pull-up in circuit layout.

P3	FEMPXOUT3	Analog Output	Multiplexer Output 3 for Signal Monitoring. The pin is not allowed to pull-up in circuit layout.
R5	FEOSCEM	3.3V LVTTTL I/O,5V-tolerance, Slow slew,2, 4, 6, 8mA PDR,75K pull-up	High frequency modulation enable signal output, or LDD serial interface CLK or I2C SCL. The pin is spike-free at power-on stage.
W4	FEPLAY_	3.3V LVTTTL I/O,5V-tolerance, 6 mA,75K pull-up	Play/pause key input, active low. The pin is spike-free at power-on stage.
K2	RFIN	Analog Input	Differential Input of AC Coupling RF SUM Signal (Negative)
L2	RFIN2	Analog Input	Differential Input of AC Coupling RF SUM Signal (Negative)
K1	RFIP	Analog Input	Differential Input of AC Coupling RF SUM Signal (Positive)
L1	RFIP2	Analog Input	Differential Input of AC Coupling RF SUM Signal (Positive)
M3	TLO	Analog Output	Tilt servo output
V6	FETRAYSIN_	3.3V LVTTTL I/O,5V-tolerance, 6 mA,75K pull-up	Tray_is_in Input, A Logical Low Indicates the Tray is IN. Feedback Flag is from Tray Connector. The pin is spike-free at power-on stage.
V5	FETRAYSOUT_	3.3V LVTTTL I/O,5V-tolerance, 6 mA,75K pull-up	Tray_is_out Input. A Logical Low Indicates the Tray is OUT. Feedback Flag is from Tray Connector. The pin is spike-free at power-on stage.
N4	FETRAYS_PWM	Analog Output	Tray DAC / PWM control output. Controlled by μ P.
G3	TRINA	Analog Input	Input of Tracking Signal (A)
H4	TRINB	Analog Input	Input of Tracking Signal (B)
H3	TRINC	Analog Input	Input of Tracking Signal (C)
H5	TRIND	Analog Input	Input of Tracking Signal (D)
M4	TRO	Analog Output	Tracking servo output. PDM output of tracking servo compensator.
K6	V14	Analog Output	Output of Voltage Reference (1.4V)
F3	VDAC0	Analog Output	Output of General DAC
H6	FVREF	Analog Output	Output of Voltage Reference
E3	VRDCO	Analog Output	Output Voltage of Laser Diode Control in APC
F4	VWDC1O	Analog Output	Output Voltage 1 of Laser Diode Control in APC
E1	VWDC2O	Analog Output	Output Voltage 2 of Laser Diode Control in APC
G5	VWDC3O	Analog Output	Output Voltage 3 of Laser Diode Control in APC
Y3	AVDD12_SATA 1	Power	1.2V analog power for SATA
Y5	AVDD33_SATA	Power	3.3V analog power for SATA
W6	AVSS12_SATA 1	Ground	Analog ground for SATA
Y1	SRXN	Analog	NC
Y2	SRXP	Analog	NC
W2	STXN	Analog	NC
W1	STXP	Analog	NC
Y4	SREXT	Analog	SATA bias resistor
D7, D8	VDD12_HDMI_RX	Power	Analog 1.2 power for HDMIRX
C7, C8	VDD33_HDMI_RX	Power	Analog 3.3 power for HDMIRX
E8, F8	VSS33_HDMI_RX	Ground	Analog ground for HDMIRX
A6	RX2B	Analog	NC
B6	RX2	Analog	NC
A7	RX1B	Analog	NC
B7	RX1	Analog	NC
A8	RX0B	Analog	NC
B8	RX0	Analog	NC
A9	RXCKB	Analog	NC
B9	RXCK	Analog	NC
F28	VDINCLK	I/O	NC / MB140 (NOAH_VCK)
F27	VDINVSYNC	I/O	NC / MB140 (NOAH_VS)
E28	VDINHSYNC	I/O	NC / MB140 (NOAH_HS)
E27	VDIN0	I/O	NC
D28	VDIN1	I/O	NC
D27	VDIN2	I/O	NC
C28	VDIN3	I/O	NC
C27	VDIN4	I/O	NC / MB140 (NOAH_XRST)
B28	VDIN5	I/O	NC / MB140 (HDMI_XRST)
D26	VDIN6	I/O	NC
A28	VDIN7	I/O	Syscon Req (IFCON)
B27	VDIN8	I/O	NC / MB140 (HDMI_MCLK)
A27	VDIN9	I/O	NC / MB140 (HDMI_BCLK)
C26	VDIN10	I/O	NC / MB140 (HDMI_LRCK)
A26	VDIN11	I/O	NC / MB140 (HDMI_SD0)
B26	VDIN12	I/O	NC / MB140 (NOAH_C0)
A25	VDIN13	I/O	NC / MB140 (NOAH_C1)
B25	VDIN14	I/O	NC / MB140 (NOAH_C2)
A24	VDIN15	I/O	NC / MB140 (NOAH_C3)
B24	VDIN16	I/O	NC / MB140 (NOAH_C4)
D23	VDIN17	I/O	NC / MB140 (NOAH_C5)
C23	VDIN18	I/O	NC / MB140 (NOAH_C6)
D22	VDIN19	I/O	NC / MB140 (NOAH_C7)
C22	VDIN20	I/O	MIC_Mute
E23	VDIN21	I/O	MIC_Det
E22	VDIN22	I/O	NC / MB140 (NOAH_Y0)
F22	VDIN23	I/O	NC / MB140 (NOAH_Y1)
A22	VDIN24	I/O	NC / MB140 (NOAH_Y2)
B22	VDIN25	I/O	NC / MB140 (NOAH_Y3)
A21	VDIN26	I/O	NC / MB140 (NOAH_Y4)

B21	VDIN27	I/O	NC / MB140 (NOAH_Y5)
E20	VDIN28	I/O	NC / MB140 (NOAH_Y6)
C20	VDIN29	I/O	NC / MB140 (NOAH_Y7)
D21	VDIN30	I/O	NC
C21	VDIN31	I/O	NC
E21	VDIN32	I/O	XIF_CS
D20	VDIN33	I/O	NC / MB140 (HDMI_XINT)
F21	VDIN34	I/O	NC
G20	VDIN35	I/O	NC / MB140 (NOAH_HCLK)
C24	CEC	I/O	NC
F9	GPIO0	I/O	NC / MB140 (NOAH_DE)
E9	GPIO1	I/O	Start Bit (IFCON)
G9	GPIO2	I/O	NC / MB140 (CSI_NOAH_XCS)
D9	GPIO3	I/O	NC / MB140 (CSI_CKO)
AD6	GPIO4	I/O	NC
AE6	GPIO5	I/O	NC
AE5	GPIO6	I/O	UPG_STATUS (IFCON)
AC7	GPIO7	I/O	USB_VBUS_PCONT, USB Power Control
C25	HDMISCK	I/O	HDMI I2C Clock
D24	HDMISD	I/O	HDMI I2C Data
D25	HTPLG	I/O	HDMI Hot Plug / MB140 (NC)
K25	IR	I/O	NC
L26	LCDRD	I/O	IF_SDI
D3	RSTI	I	Front-End Power on reset
K24	OPWRSB	I/O	Power Control
K23	RESET	I	Power on reset
J25	UARXD	I/O	RS232 Rx Pin
K26	UATXD	I/O	RS232 Tx Pin
M24	VCLK	I/O	IF_CLK
M23	VDATA	I/O	IF_SDO
L25	VSTB	I/O	XVMUTE, Video Mute

SECTION 7
SERVICE MODE

Main function

■ Enter Service Mode

[OPTION 1]

The set disconnect AC, and Push front panel key ([OPEN/CLOSE] + [PLAY] + [STOP]) and AC IN The keys will be released if the character of "SERVICE" displays on a front panel display. After that, the screen in service mode is displayed on a monitor.
Control via Remote Controller

[OPTION 2]

Connect the set to AC, and wait initialization cycle complete (FLD will show "wait.. Wait.." for about 10s)
Use Sony BDP remote controller, key in the following SIRCS code.
[DISPLAY] → [0] → [2] → [1] → [1] → [SUBTITLE]
While sending of SIRCS code, wait time between each key code could not send later then 3 second.
If 3 second waiting is exceeded user have to re-key in the SIRCS code.
If SIRCS enter is successful, set will auto boot up and FLD will display SERVICE. The screen of service mode is displayed on a monitor.
Control via Remote Controller

Main function

- **Diag**
The unit test of the device mounted on the MainBoard.
The unit test of the device mounted on the wireless board. (only wireless model)
- **Display Error Log**
Error log is displayed.
The displayed logs can be saved in a USB memory.
- **Factory Initialize**
Return all of the player setting to their factory defaults.
- **Network**
Confirm Wired Network connection.
- **Version Up**
The set updates by Update DISC.
- **System Information**
System information of the set is displayed.
The Information on a soft version and drive information, etc. is displayed.
- **EMC Test Mode**
Not used.
- **Drive**
Write Drive OP Data and check drive.

Menu

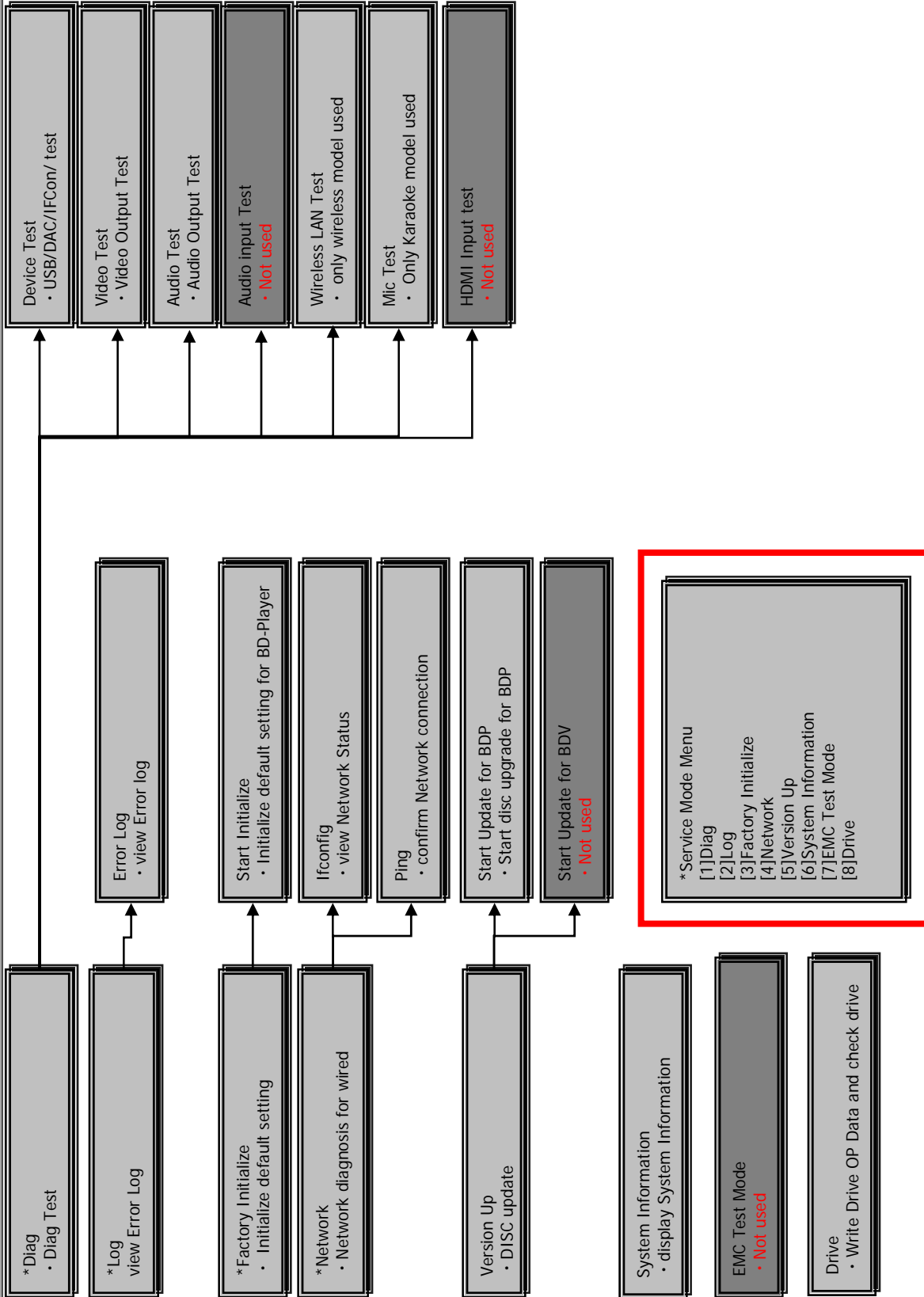

S e r v i c e M o d e M e n u

Outline :
 Service Mode Top Menu
 It selects to each function from here.
 output HDMI/Component 480p forcibly.

Operation :

[1]	Select and Activate Diag Menu.
[2]	Select and Activate Log Menu,
[3]	Select and Activate Factory Initialize Menu.,
[4]	Select and Activate Network Menu
[5]	Select and Activate Version Up (DISC version Up) Menu,
[6]	Select and Activate System Information Menu.
[7]	Select and Activate EMC Test Mode Menu. (not Used)
[8]	Select and Activate Drive Menu.
[UP]	Move Up cursor
[DOWN]	Move Down cursor
[ENT]	Activate the selected cursor.

*The cursor is not displayed when initial.

Front Panel Display :
 If cursor or arbitrary menu keys are operated,
 the character will output to a front panel display, respectively.

*the character string.	SERVICE
initial display	S-DIAG
Diag :	S-LOG
Log :	S-FINIT
Factory Initial ze:	S-NET
Network:	S-VUP
Version Up	S-INFO
System Information:	S-EMC
EMC Test Mode:	S-DRV
Drive:	

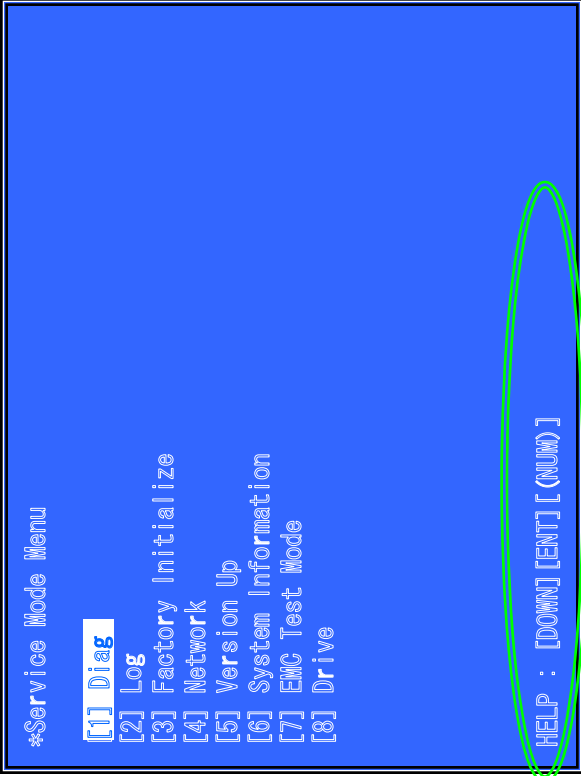

Display Hint
 (The key in which the present use is possible)

Diag Menu (Device Test)

(window 1)
* Diag

Category: **Device Test**

USB Host

(Window 2)
* Diag

Category: Device Test
Device:

Rear USB Media check ... OK
Front USB Media check ... OK

Checking...

HELP: [RIGHT][UP][ENT][RET]

(Window 3)
* Diag

Category: Device Test
Device: IFCON

FDP all ON
Show strings
LED Sequential ON
Fan Control ON

IFCON

FanState: OFF

HELP: [LEFT][RIGHT][UP][DOWN][ENT][RET]

(Window 4)
* Diag

Category: Device Test
Device: MIC

Mic connect check ... OK

Checking...

HELP: [RIGHT][UP][ENT][RET]

Outline :
The device carried in the substrate is tested.

(Window 1) Select test category
Operation :
[LEFT][RIGHT] Select Category
[DOWN][ENT] Activate the selected Category.
[RET] Return to Service Top Menu.

(Window 2) Device Test
After "Device Test" selects in window 1, the device to test is chosen.
Operation:
[LEFT][RIGHT] Select Device
[ENT] Activate and Start Test
[UP] Return to test category selection.
IF select IFCON, Move Up cursor. (see windows 3)
IF select IFCON, Move Up cursor. (see windows 3)
[DOWN] Return to test category selection.
[RET]

> Test category list
Device Test
Video Test
Audio Test
Audio Input Test
Wireless LAN Test **(not Used) (only Wireless Model)**
Mic Test **(only Karaoke Model)**
HDMI Input Test **(not Used)**

> Device Test : Device List
USB Host : USB Media Check (Front and Rear) **Only one time.**
D/A Converter : DAC write check (non-verification)
IFCON : IFCON Test (see windows 3)
FDP all ON
Show Strings
LED Sequential
FAN Control ON
Fan State (Display)
MIC : MIC connect check (see window 4)
IPC : Device ID check **(only S780)**
External HDMI : Revision check **(only S780)**

Diag Menu (Device Test) (additional)

Front Panel Display :	
Device Select :	USB : D-MIC
	D/A Converter : D-DAC
	IFCON : D-IFCON
	MIC : D-MIC
	IPC : D-IPC
	External HDMI : D-EXH
Video Test :	: D-VIDEO
Audio Test :	: D-AUDIO
Wireless LAN Test	: D-WLLAN
	HwInfo : D-WLIF
	AP Connect : D-CNAP
	RSSI Value : D-RSSI
	Ping Test : D-PING
MIC connect check :	: MIC CHK
	all the items O.K. : MIC OK
	Except the above : MIC NG
IPC Device ID check :	: IPC CHK
	all the items O.K. : IPC OK
	Except the above : IPC NG
External HDMI Revision check :	: EXH CHK
	all the items O.K. : EXH OK
	Except the above : EXH NG

Diag Menu (Video Test/ Audio Test)

Outline:
Activate Video Test and Audio Test

(Window 1) Select Video Test Category
Operation:
[ENT] Activate and display Color Bar
[UP][RET] Return to test category selection.

(Window 2) Display Color Bar
Operation :
[ENT] Return to Select Video Test Category.

(Window 3) Select Audio Test Category
Operation :
[ENT] Play TONE Sound/Stop
[UP][RET] Return to Select Audio Test Category

>Video Test:
Color Bar output S terminal & composite & Component & HDMI.

>Audio Test:
TONE sound output ineOut(2ch)&/ SPDIF & HDMI.

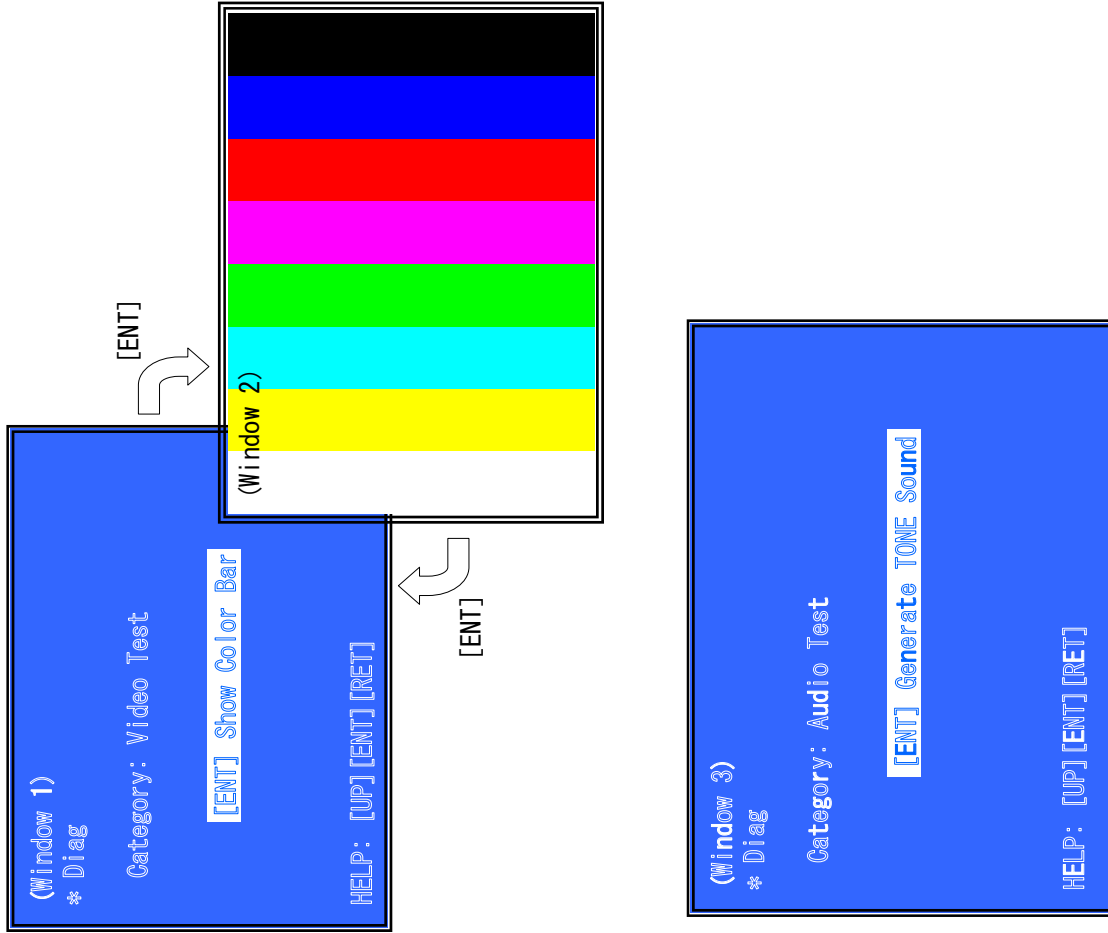

Diag Menu (Wireless LAN Test) <only Wireless Model>

Outline:
 Activate Wireless LAN Tests
(Window 1) Select Wireless LAN Test Category
Operation:
 [LEFT] [RIGHT] Select Category
 [DOWN][ENT] Activate the selected Category.
 [RET] Return to Service Top Menu.
(Window 2) Select Wireless LAN Test
Operation:
 [1] Show Wireless LAN module Information
 [2] Connect Access Point
 [3] Start display RSSI value.
 [4] Start Ping Test
 [UP][DOWN] Select Test
 [ENT] Activate and Start Test
 [RET] Return to test category selection.

> **Show WLAN HwInfo (See Window 2)**
 Serial : Serial Number
 Hard : Hardware Version
 Mac : Mac Address

> **Connect to Access Point (See Window 3)**
 Connect Access Point only with the following AP settings.
Authentication method: NO-ENCRYPT
WEP key : abcdef1234
SSID : SONY-Test-R
PMK : ABCDEF12345
IP: 192.168.1.10
Net mask: 255.255.255.0
Broadcast : 192.168.1.255

- When connect to AP, Status is "Connected!"
 When cannot connect to AP, Status is "can't Connect!"

> **Start Display RSSI Value (See Window 4)**
 Display RSSI value.

> **Start Ping Test (See Window 5)**
 Ping Test.
 IP address use the value of "192.168.1.10".

(Window 1)

```
* Diag
Category: Wireless LAN Test
```

(Window 2)

```
* Diag
Category: Wireless LAN Test
[1] Show WLAN HwInfo
[2] Connect to AccessPoint
[3] Start Display RSSI Value
[4] Start Ping Test

Serial : 200912313165535
Hard : 0x04
Mac : 00:01:36:23:FD:CF

HELP: [ (NUM) ] [RET]
```

(Window 4)

```
* Diag
Category: Wireless LAN Test
[1] Show WLAN HwInfo
[2] Connect to AccessPoint
[3] Stop Display RSSI Value
[4] Start Ping Test

RSSI Value : 60

HELP: [ (NUM) ] [RET]
```

(Window 3)

```
* Diag
Category: WirelessLAN Test
[1] Show WLAN HwInfo
[2] Connect to AccessPoint
[3] Start Display RSSI Value

CERT : NO-ENCRYPT
WEPKEY : abcdef1234
PMK : ABCDEF12345
SSID : SONY-Test-R
IPADDR : 192.168.1.10
NETMASK: 255.255.255.0
BCADDR : 192.168.1.255

Status : Connected!
HELP: [ (NUM) ] [RET]
```

(Window 5)

```
* Diag
Category: Wireless LAN Test
[1] Show WLAN HwInfo
[2] Connect to AccessPoint
[3] Stop Display RSSI Value
[4] Start Ping Test

Ping To : 192.168.1.10
PING 192.168.1.10 OK!

HELP: [ (NUM) ] [RET]
```

Diag Menu (MIC Input Test) <only Karaoke Model1>

Outline:
 Activate MIC Input Test

(Window 1) Select MIC Input Test Category
Operation :
 [LEFT] [RIGHT] Select Category
 [DOWN][ENT] Activate the selected Category.
 [RET] Return to Service Top Menu.

(Window 2) Select Input Device
 After "MIC Input Test" selects in window 1, the device to test is chosen.
Operation:
 [ENT] Activate and Start Test/Stop
 [RET] Return to test category selection.

>Audio Input Test:
 Path test from MIC to LineOut(2ch)/ SPDIF/HDMI and Line Out (8ch) through 8555.
 Check tone sound by speaker.

Front Panel Display:
 MIC Input Test Select: D-MIC

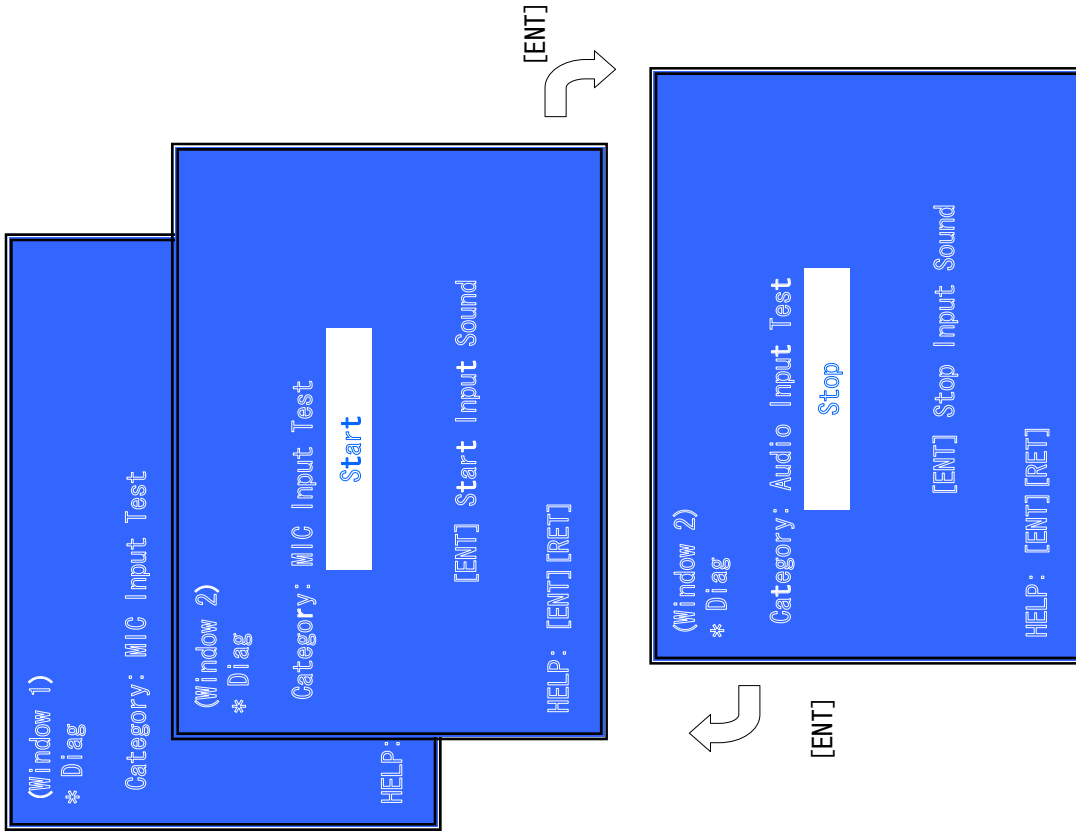

Log: Error Log

Outline :
 Display each contents of the Error log,

(Window 1) select log.
Operation :
 [1] Activate and Display Error log
 [UP] Move Up cursor
 [DOWN] Move Down cursor
 [ENT] Activate the selected cursor.
 [RET] Return to Service Top Menu.

(Window 2) : Display Error Log
Operation : Next Page
 [LEFT] Previous Page
 [RIGHT] Return to select log (window 1)
 [RET] Write the contents of an error log on a USB memory.
 [RED]

Front Panel Display :
 select log Error Log : S-ELOG
 Display Page display page ex) 001/050

>Log contents
 Error Log : 08/01/01 00:53:19: [ErrCode:080400000000]
 [Date] [Time] [ErrCode]

****Write the contents of a log on a USB memory****
 [RED] is pushed where a USB memory is inserted in a set in log display screen.
Please do not push the RED button immediately after USB memory is inserted.
Please do not pull out USB memory immediately after the RED button was pushed.
 Error Log:
 "getErrLogFile.trm" file is outputted in a USB memory.

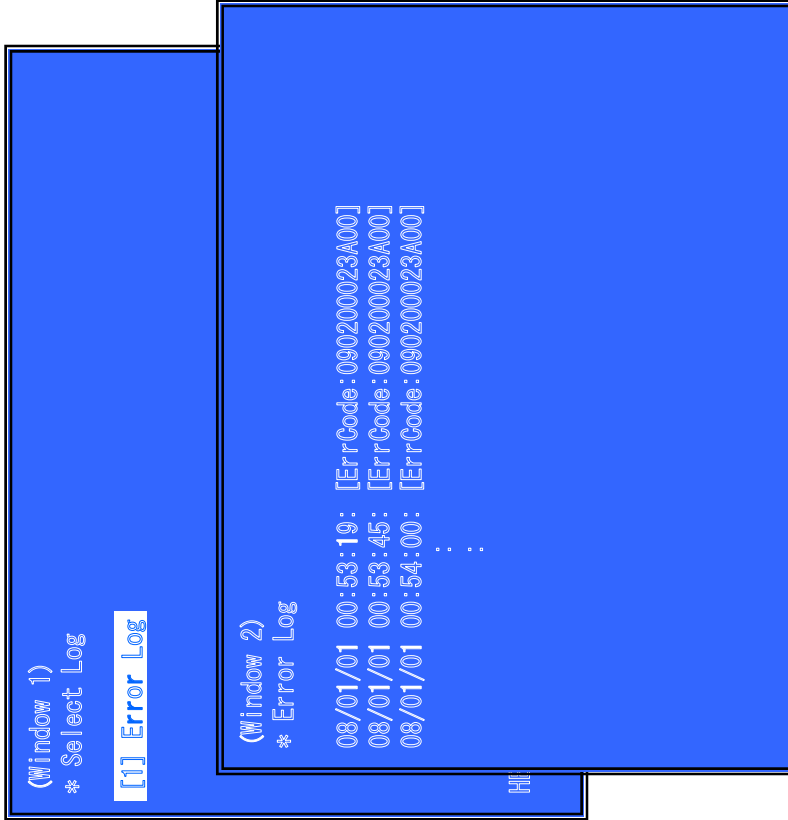

Factory Initialize

Outline:
 Return all of the player setting to their factory defaults.

(Window 1) select initialize.

Operation :
 When you return a set to the factory defaults, push [1] on this screen.
 [ENT] Start Factory Initialize
 [RET] Return to Service Top Menu.

(Window 2)
 It is a screen of the end of initialization.
 [RET] Return to Service Top Menu.

Please disconnect AC power supply, and connect AC again.
 - The operation of other service mode menu can be continued.

Front Panel Display:
 Initialize : SETTING
 Initialize OK : INIT-OK (window 2)
 Initialize NG : INIT-NG

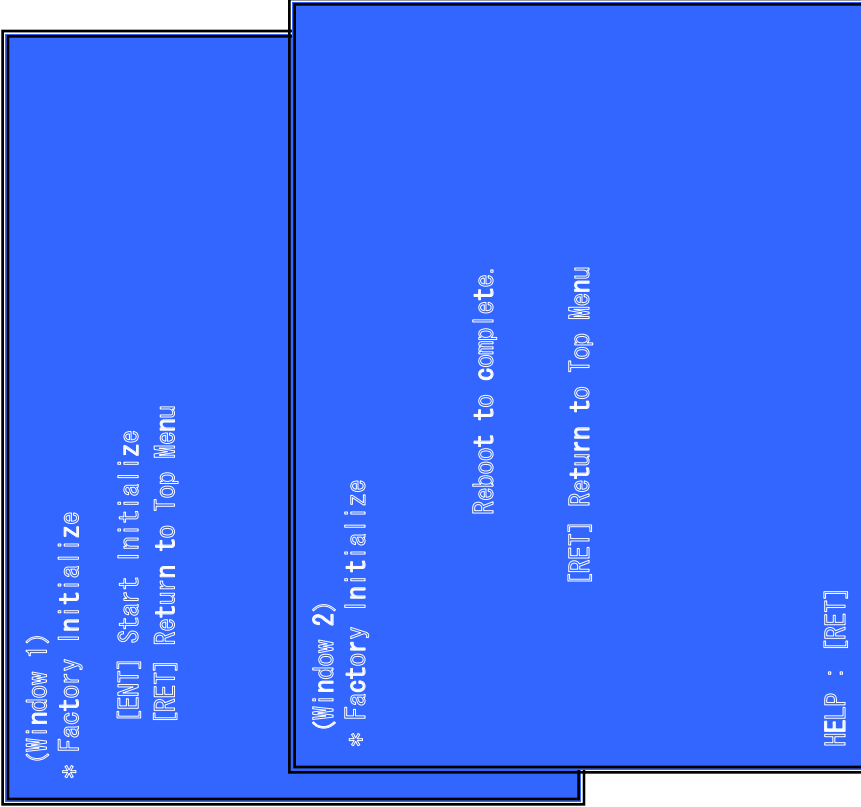

Network (Network Test: Ifconfig)

Outline :
 Network Menu for the wired Ethernet.

(Window1)Ifconfig Test
Operation : Activate Ifconfig (Display network setting)
 [ENT] Select Ping Test.
 [RIGHT] Return to Service Top Menu.
 [RET]

(Window 2)Ping Test
Operation: Select Ifconfig Test.
 [LEFT] Return to Service Top Menu.
 [RET] (The details of a Ping test are next page)

(Window 3)Ifconfig Test Active
 Display Ifconfig command results.
Operation: Ifconfig retry
 [ENT] Select Ping Test.
 [RIGHT] Return to Service Top Menu.
 [RET]

Front Panel Display :
 S-NET

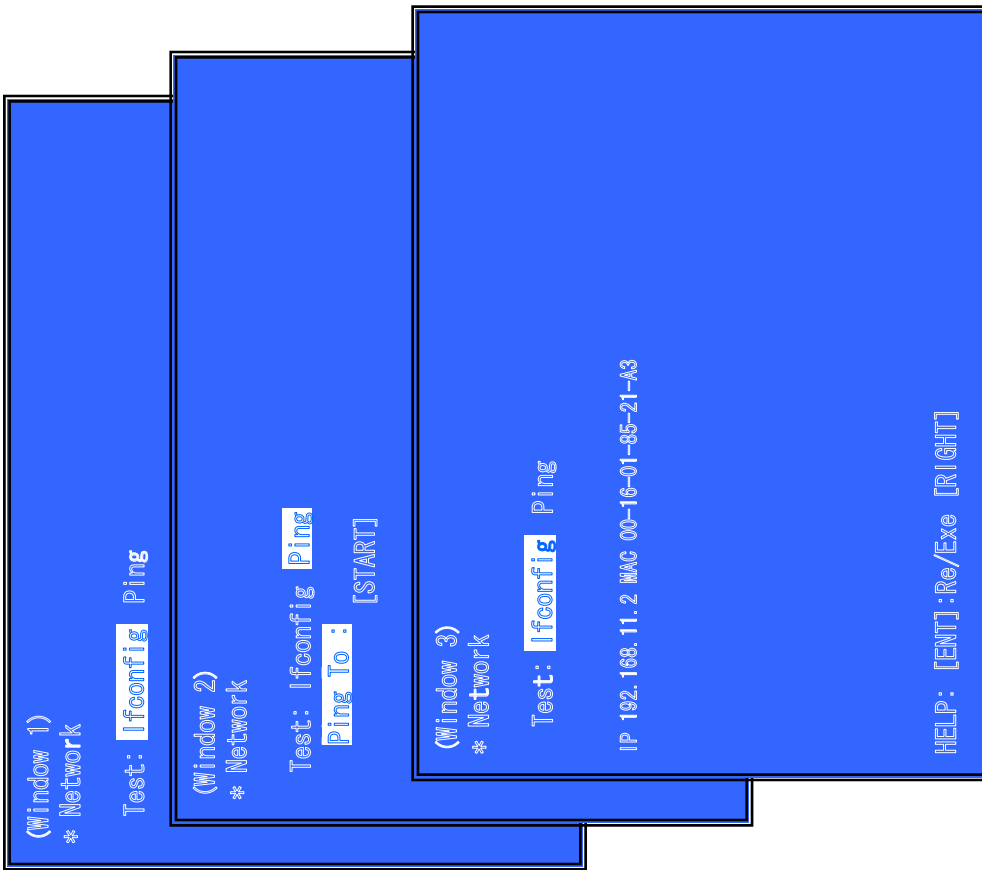

Network (Network Test: Ping)

Outline :
Ping Test for the wired Ethernet.

(Window 1) Ping Test
Operation: Select Ifconfig Test.
 [LEFT] Ping execution preparation.
 [DOWN] Return to Service Top Menu.
 [RET]

(Window 2) The IP address of the Ping point is set up.
(IP address input mode)
 When "Ping to :>" is reversed, [ENT] is pushed and IP is inputted.
Operation:
 [ENT] Finish to input.
 [RET] Finish to input.
 [LEFT] Finish to input and Select Ifconfig Test.
 [(NUM)] Input Character sting '0-9'
 [TIME] Input Character sting '.'
 [CLEAR] Backspace

(Windows3): Ping Test Active
 When [START] is reversed, [ENT] is pushed and execute ping .
Operation:
 [ENT] Activate Ping Test
 [UP] The IP address of the Ping point is set up.
 [RET] Return to Service Top Menu.

Front Panel Display :
S-NET

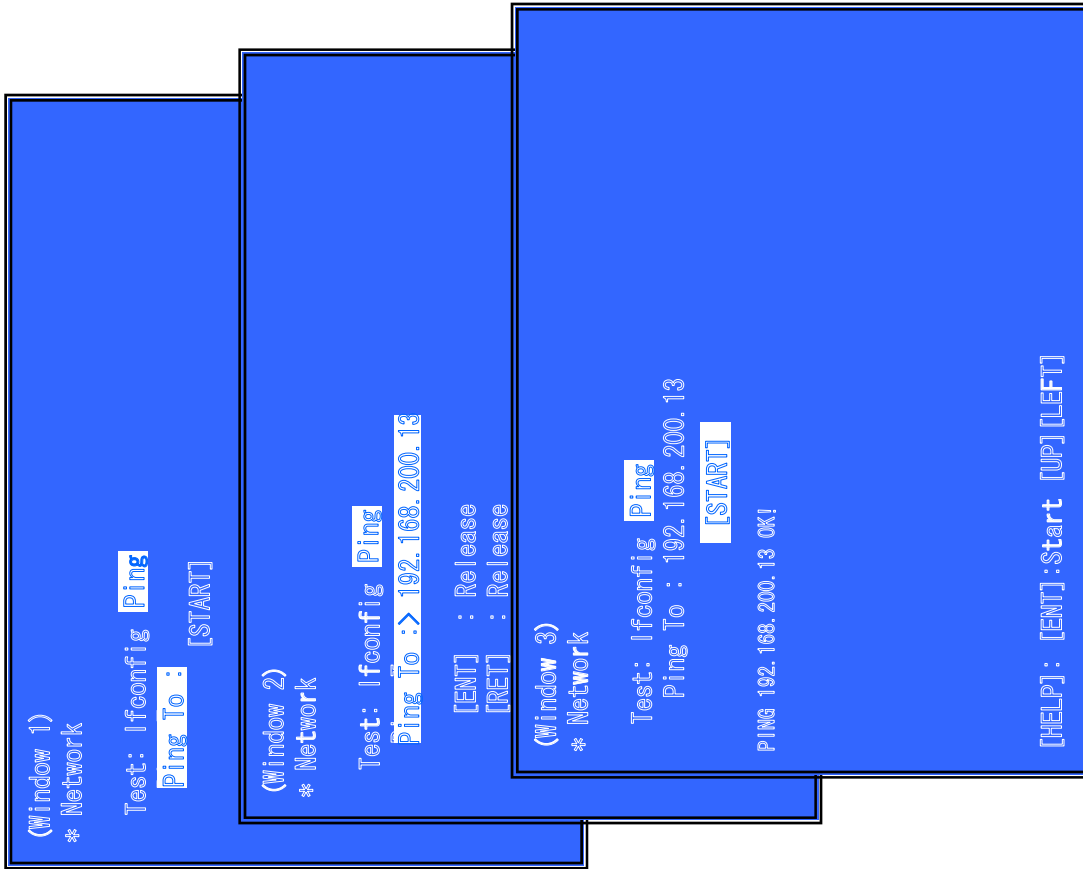

Version Up (using Update DISC)

Outline:
update software using DISC

(Window 1)Version Up Menu

Operation:

- [1] Start Update for BDP →(Tray Open and go to window 2)
- [2] Start Update for BDV **(not used)**
- [UP] Move Up cursor
- [DOWN] Move Down cursor
- [ENT] Activate the selected cursor.
- [RET] Return to Service Top Menu.

(Window 2)Place the Update Disc

Operation :

- [ENT] Tray Close and check DISC.
- [RET] Cancel Update (Tray Close and return to window 1)

(Window 3) Disc Check and OK (Right DISC)

Operation: start update sequence automatically and reboot.

After reboot, please open tray and eject Update Disc manually.

(Window 4) Disc Check and NG (not update DISC)

Operation: [Error] ... (error message) and wait.

open tray automatically.

Front Panel Display :

- DISC Insert V-INSCD
- Can't Mount V-NODSC
- DISC Check NG V-CHKNG
- DISC Check OK V-CHKOK

(Window 1)

* Version Update

[1] Start Update for BDP

[2] Start Update for BDV

[RET] Return to Top Menu

(Window 2)

* Version Update

Insert update DISC ...

[ENT] Tray Close and Check start

[RET] Cancel

(Window 3)

* Version Update

Now, mounting and checking... OK

(Window 4)

* Version Update

Insert update DISC ...

[ENT] Tray Close and Check start

[RET] Cancel

[Error] Cannot mount this DISC!

HELP: [ENT] [RET]

System Information

Outline:
 Display System Information

(Window 1)Basic Information Menu
Operation:
 [RIGHT] Drive Information (delta IOP of a drive is measured) and
 Wireless device Information (only wireless model)
 displayed. (go to window 2)
 [RET] Return to Service Top Menu.

(Window 2)Drive and Wireless Information Menu
Operation:
 [LEFT] Basic Information displayed. (go to window 1)
 [RET] Return to Service Top Menu.

When delta IOP is measured, it becomes impossible to use the Version Up function.

Contents List:

Model	
Destination	
Sequence Number	
MAC	
IP	
IFCON	IFCON Version
Bootloader	Bootloader Version
Host Main	Host Main Version
Host Sub	Host Sub Version
Middleware	Middleware Version
WLAN module Serial	
WLAN module hw version	
WLAN module MAC Address	
Drive	Firm Revision
CD DIOP	Delta IOP
DVD DIOP	Delta IOP
BD DIOP	Delta IOP
CD LD TIME	LD Time
DVD LD TIME	LD Time
BD LD TIME	LD Time

Front Panel Display :
 Display Host Main Version

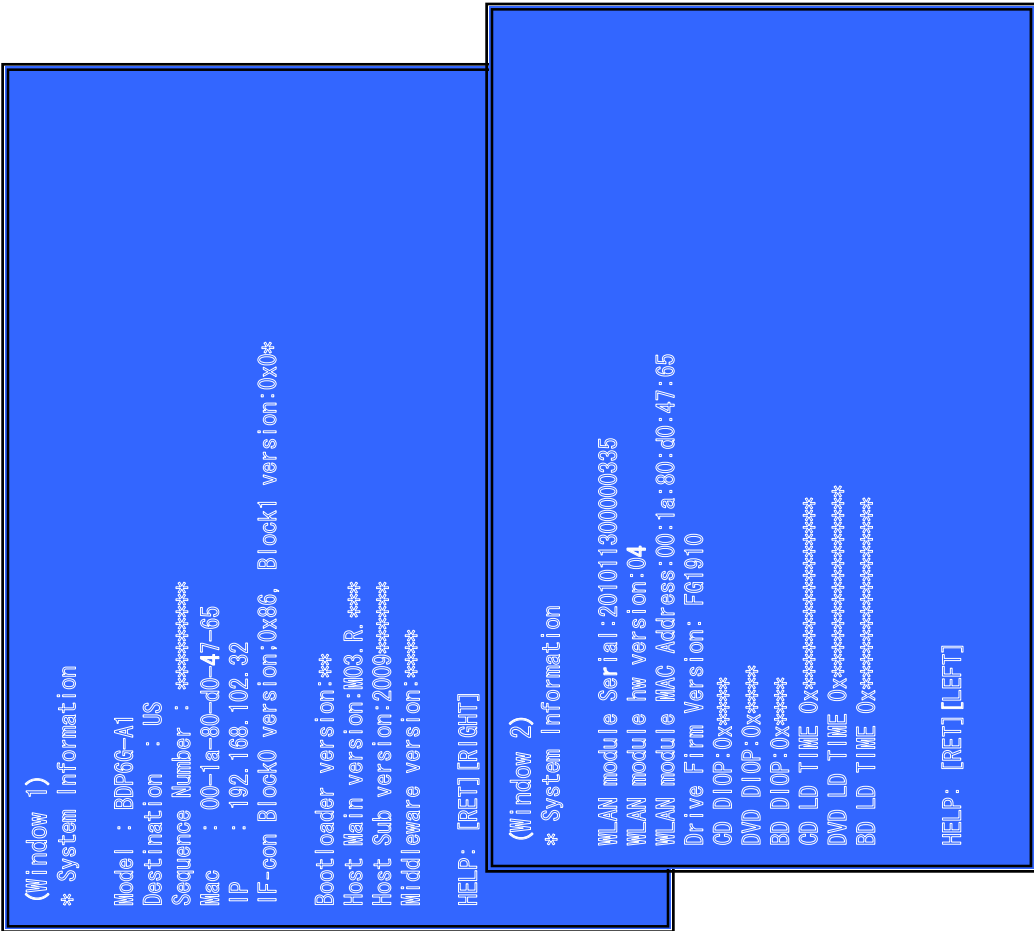

Drive Test

Outline :
 Activate Drive test

(Window 1) Select Drive test category

Operation :
 [LEFT] [RIGHT] Select Category
 [DOWN][ENT] Activate the selected Category.
 [RET] Return to Service Top Menu.
 [1] Drive OP data Write
 [2] Servo Parameter Check Menu **(Not Used)**
 [3] Servo Signal Check Menu **(Not Used)**
 [4] S-Curve Check Menu **(Not Used)**
 [5] Readability Check Menu **(Not Used)**
 [6] OP Position Check Menu **(Not Used)**
 [7] OP Check Menu **(Not Used)**
 [8] Load Eject Aging **(Not Used)**
 [9] Spindle Control Check Menu **(Not Used)**
 [10] FA Test Mode **(Not Used)**

(Window 2) To start OP data Write

Operation : Start
 [ENT]

(Window 3) Show OP data Write result

Operation :
 NG - USB is not find
 NG - File(Budata.txt) is not find
 OK - OP data write

>Drive Test:
 For drive operating check. Service is only use Drive OP data write to re write OP data after change of new OPU.

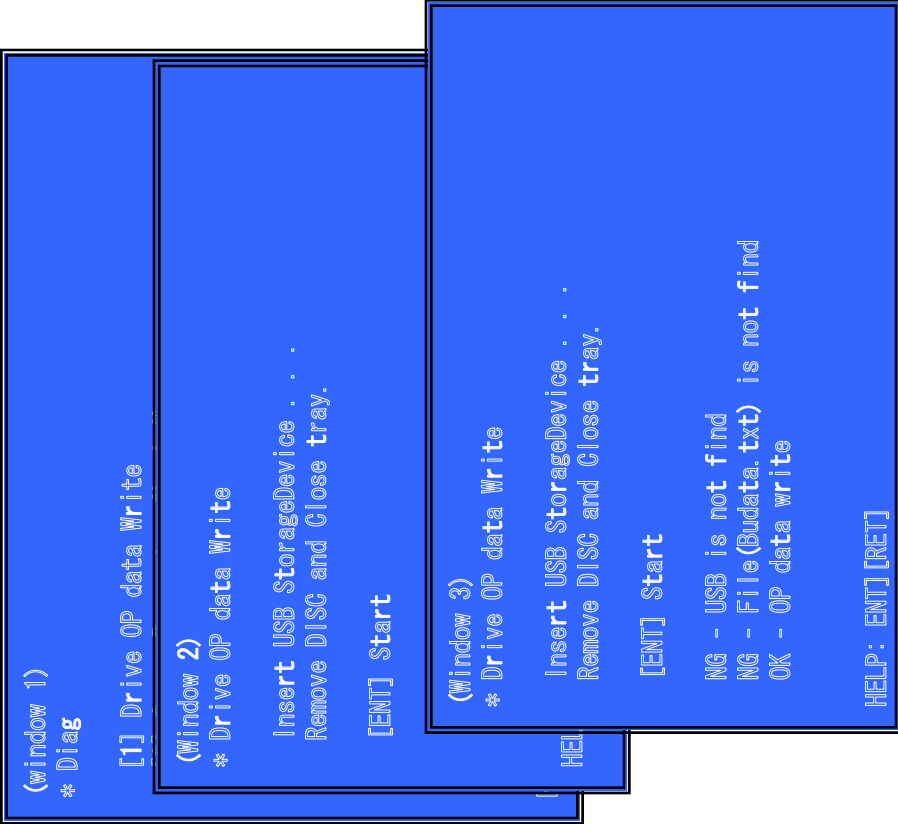

SECTION 8 ERROR LOG LIST

Error Log Information

issue	Error Log Code							note
	Category	ErrorCode	ErrorInfo_0	ErrorInfo_1	ErrorInfo_2	ErrorInfo_3		
CXD9997/CXD9988 Error	0x01		0x**					
DDR3 Error	0x02		0x**					
Ifcon transmission time out	0x03	0x01	0x00	0x00	0x00	0x00		No response from Ifcon
Ifcon Error	0x03		0x**					Other Error
NAND Init Fail	0x04	0x00	0x00	0x00	0x00	0x00		NAND initialization failed
NAND Flash read Error	0x04		0x**					Other Error
DRIVE Error	0x06	0x01						Cannot detect optical drive
DRIVE Error	0x06	0x02						SATA cable disconnected
DRIVE Error	0x06	0x03						SATA IF ERROR
DRIVE Error	0x06							Other Error
Fan error	0x07	0x01	0x01	0x00	0x00	0x00		Temperature is too high
Fan error	0x07	0x01	0x02	0x00	0x00	0x00		Can not change fan state
Ethernet Error	0x08	0x01	0x00	0x00	0x00	0x00		module initialization error
Ethernet Error	0x08	0x02	0x00	0x00	0x00	0x00		Link Error
MEDIA – OPTICAL DISC	0x09	0x01						Disc read error
MEDIA – OPTICAL DISC	0x09	0x02						Other commands read error
USB media read error	0x0A	0x01	0x1	0x1	0x00	0x00		ErrorInfo_0: LUN number ErrorInfo_1: LBA address
USB media write error	0x0A	0x02	0x1	0x1	0x00	0x00		ErrorInfo_0: LUN number ErrorInfo_1: LBA address
Unsupported USB device	0x0A	0xFF	0x1	0x1	0x1	0x1		ErrorInfo_0: Device Class ErrorInfo_1: bDeviceSubClass ErrorInfo_2: bDeviceProtocol ErrorInfo_3: bNumConfigurations
USB error	0x0A		0x**					Other Error

History

ver 0.10	2010.09.08	Manaka/Kong	First release
ver 0.20	2010.09.30	Manaka/Kong	Update for 6G item
Ver 0.30	2010.12.01	Manaka/Kong	Update error log table

SECTION 9 TROUBLESHOOTING

Main Flow	9-2
Power (System) Flow	9-3
IFcon Section Flow Chart (1/2).....	9-4
IFcon Section Flow Chart (2/2).....	9-5
Audio section flowchart.....	9-6
Video section flowchart.....	9-7
FL-203 Board flowchart	9-8
IF-170 Board flowchart	9-9
Remote does not operate.....	9-10
White LED	9-11
Drive flowchart	9-12
FAN.....	9-13
Ethernet flowchart.....	9-14
USB (Front) Device Flow.....	9-15
USB (Rear) Device Flow.....	9-16E

Main Flowchart

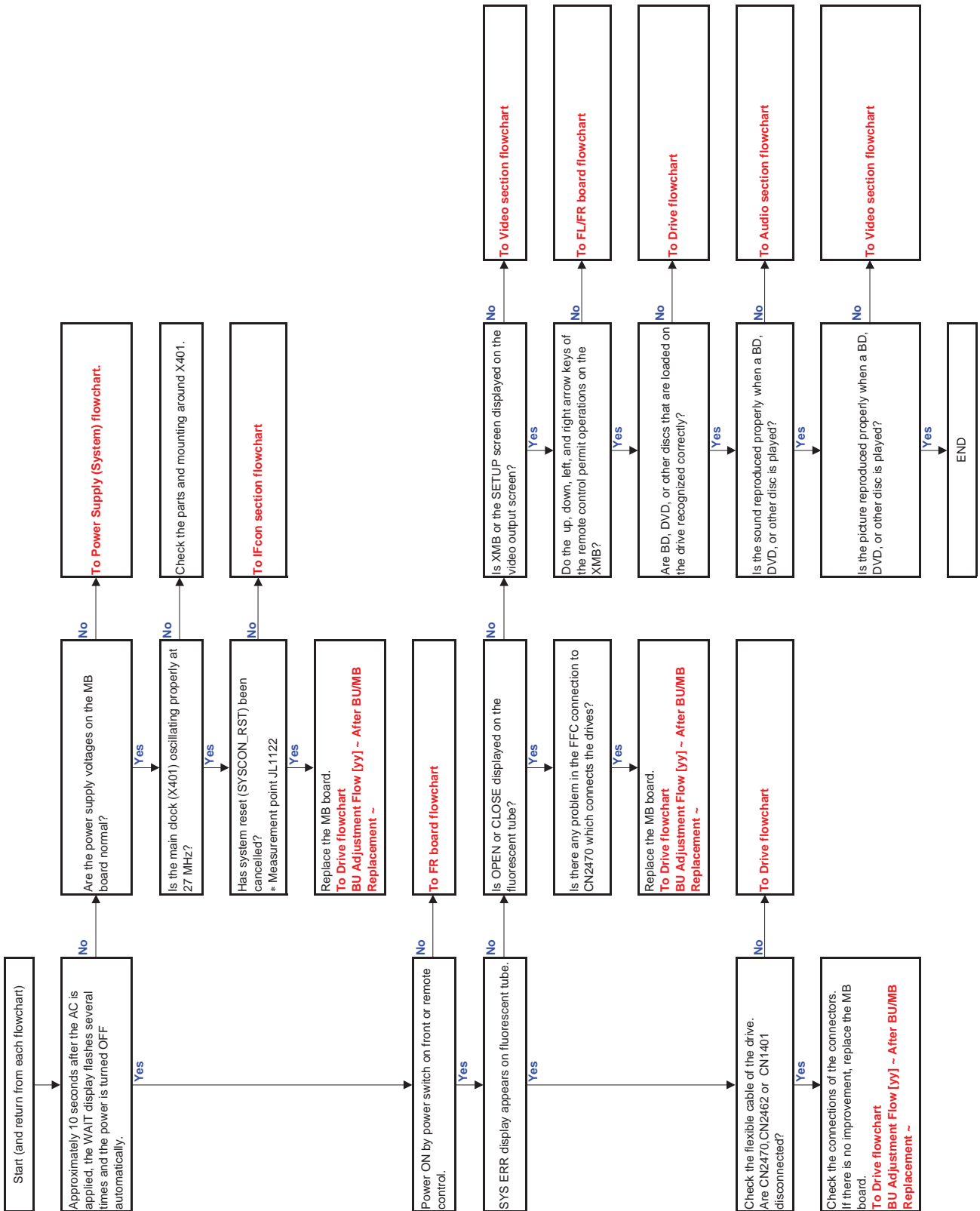

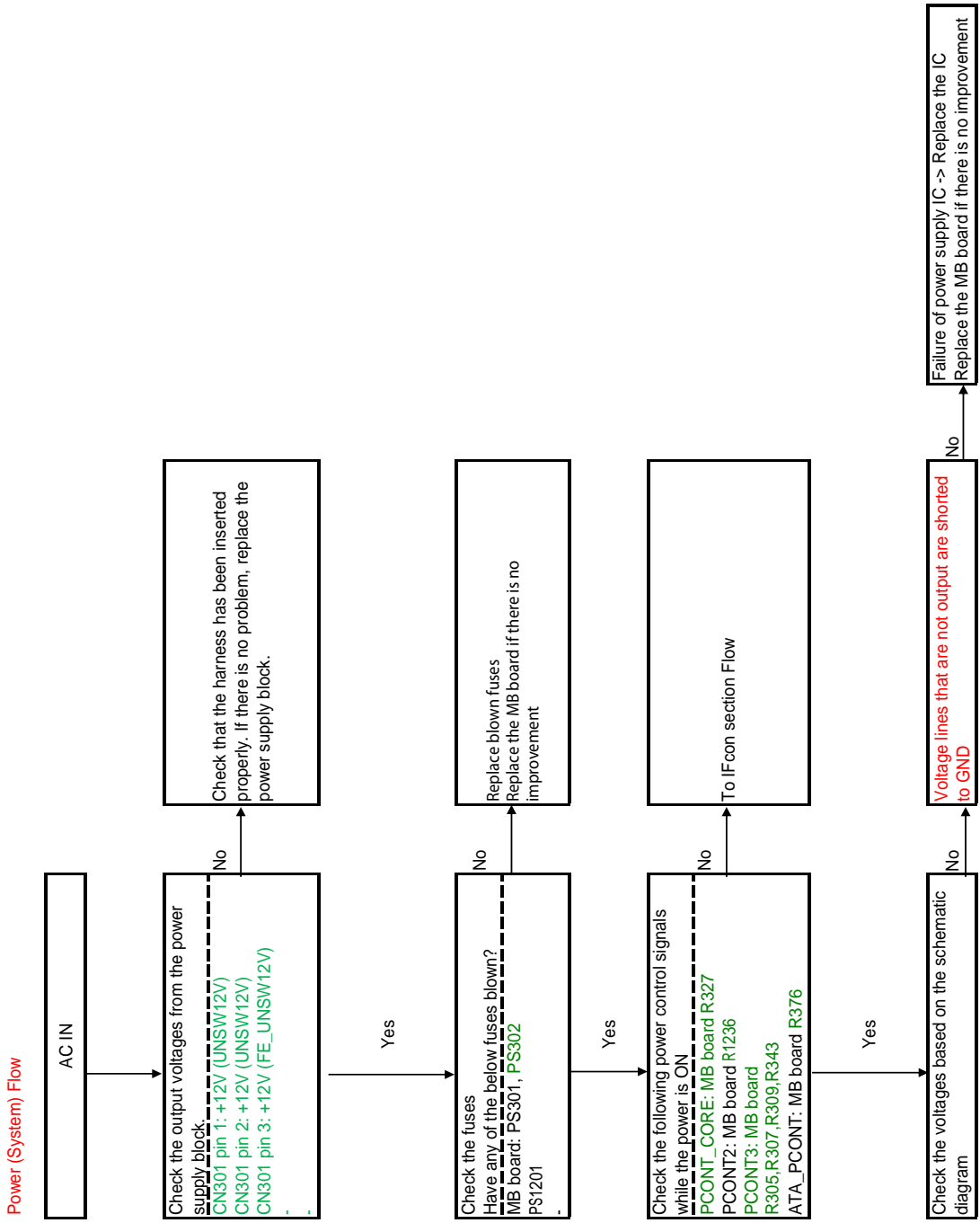

IFcon Section Flow Chart(1/2)

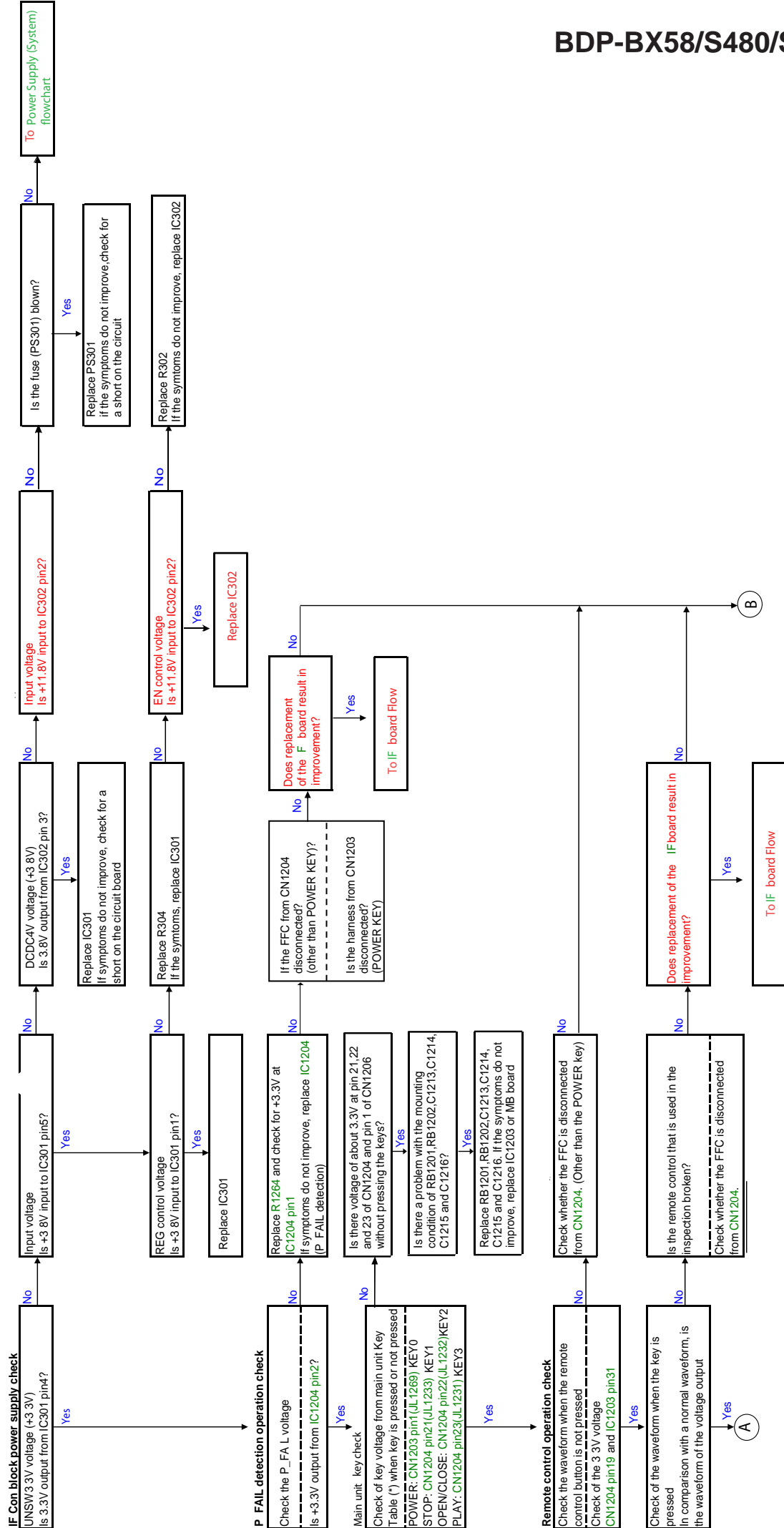

* Key Table

Input	(KEY0)	(KEY1)	(KEY2)	(KEY3)
2.90 -	Key_OFF	Key_OFF	Key_OFF	Key_OFF
0.00 -	POWER	STOP	OPEN/CLOSE	PLAY

IFcon Section Flow Chart(2/2)

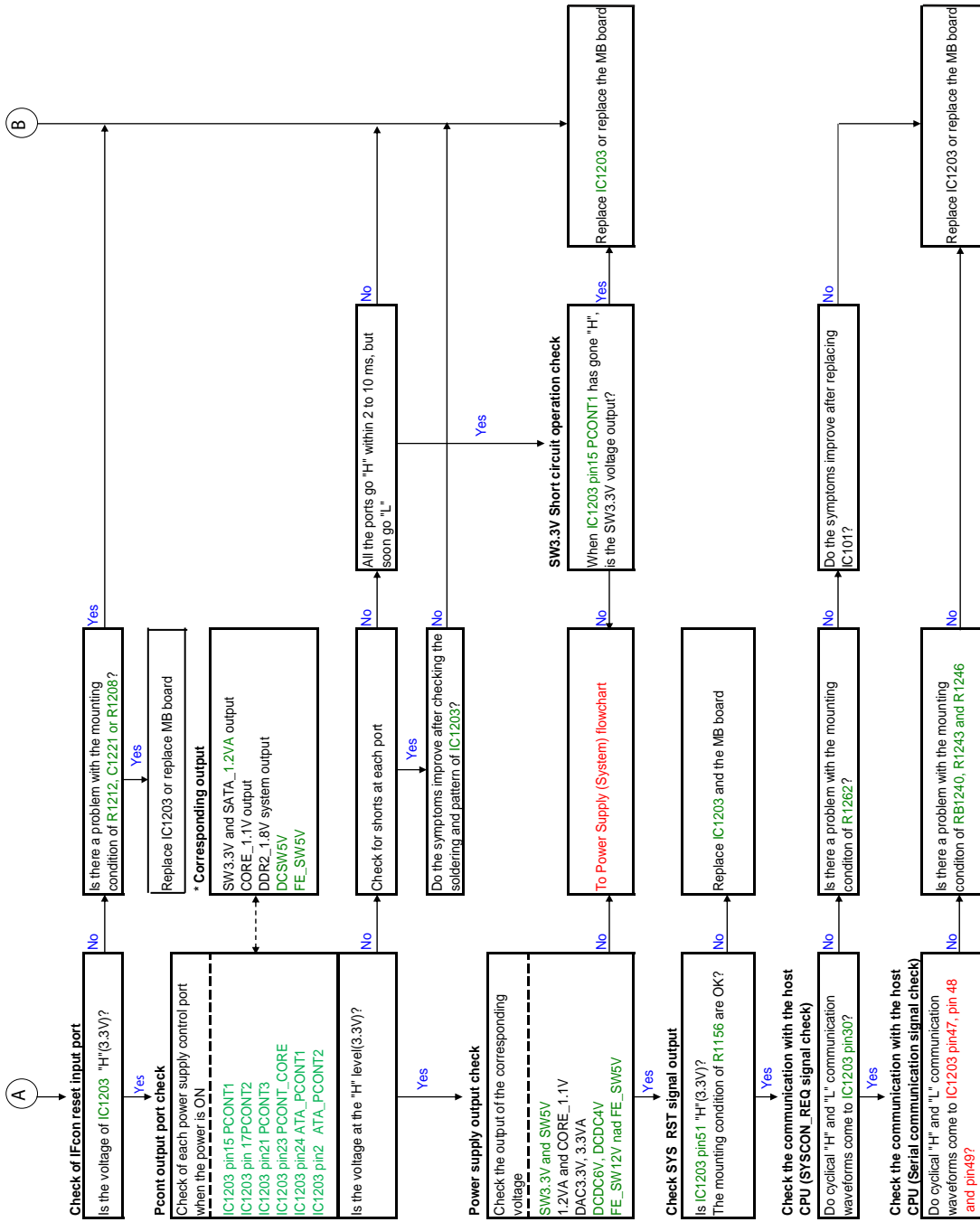

Audio section flowchart

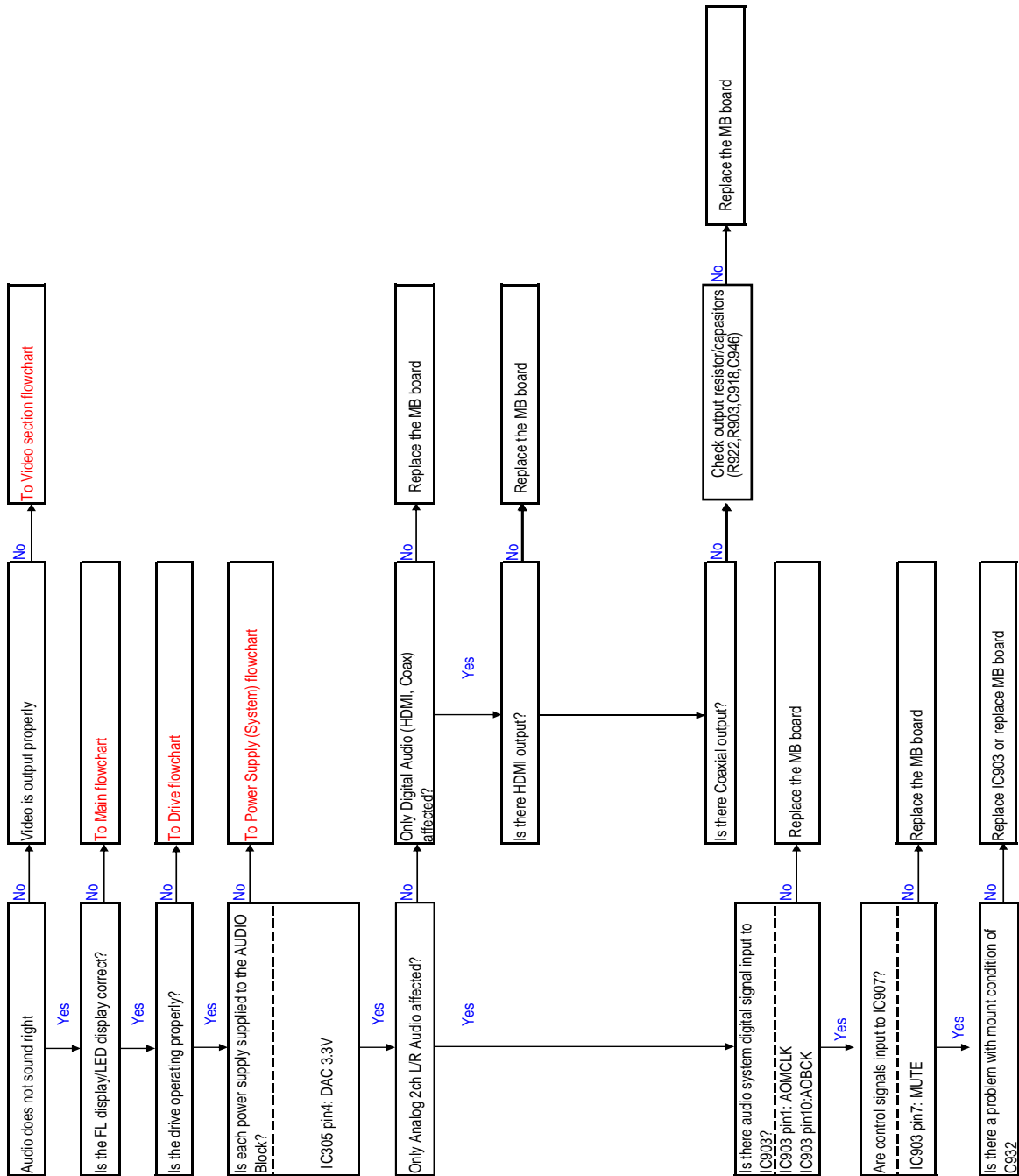

Video section flowchart

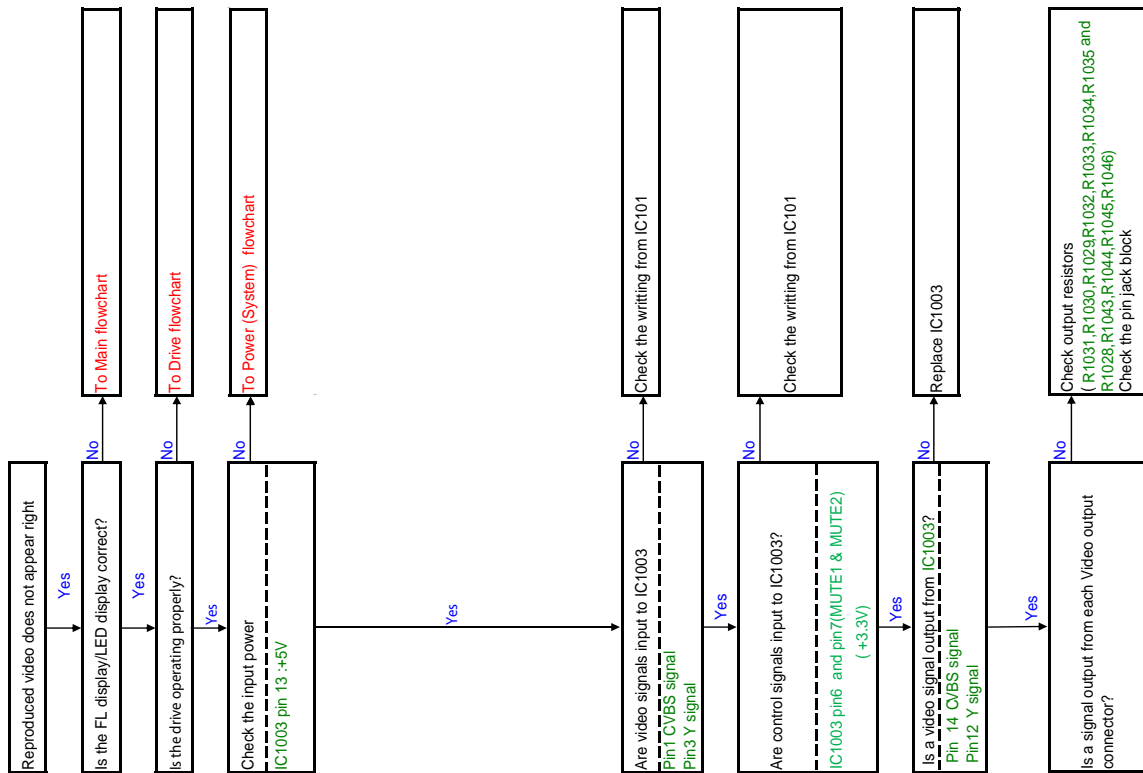

FL-203 Board flowchart

Power button on the main unit does not work

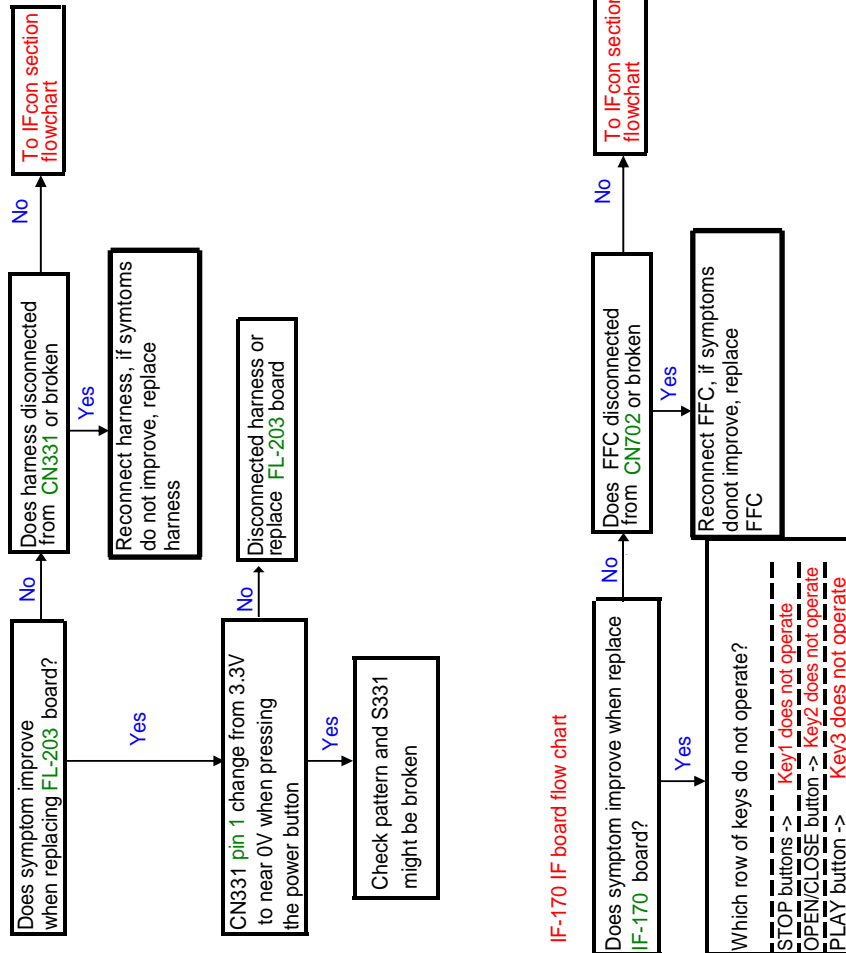

Reference: Relationship of Buttons and Voltages

Input	KEY0	KEY1	KEY2	KEY3
2.90-3.30	Key_OFF	Key_OFF	Key_OFF	Key_OFF
0.00-0.40	POWER	STOP	OPEN/CLOSE	PLAY

Key1 does not operate

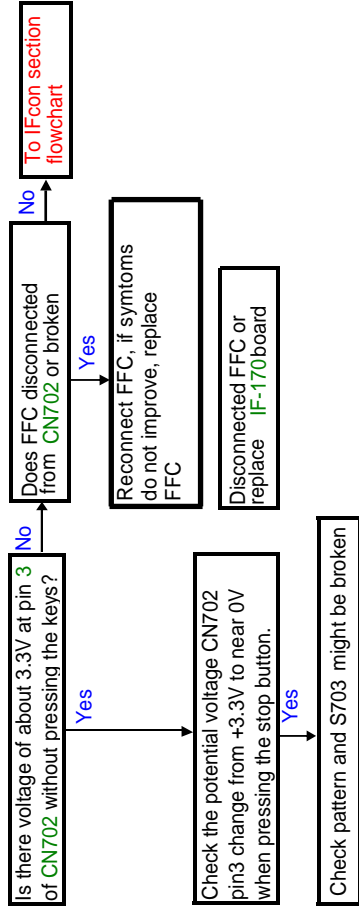

Key2 does not operate

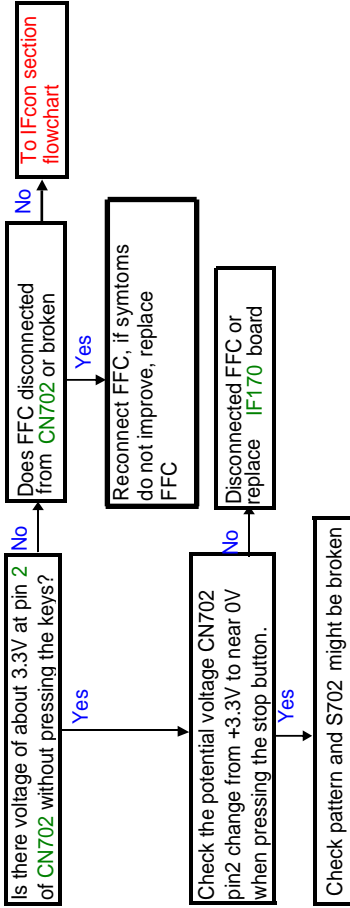

Key3 does not operate

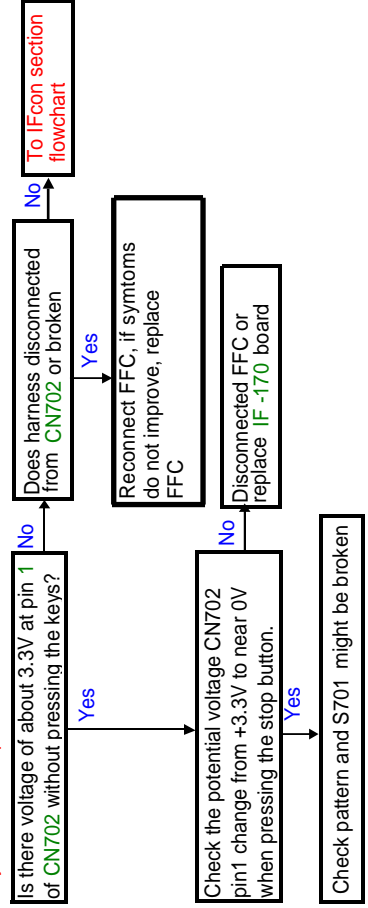

IF-170 Board flowchart

VFD does not light

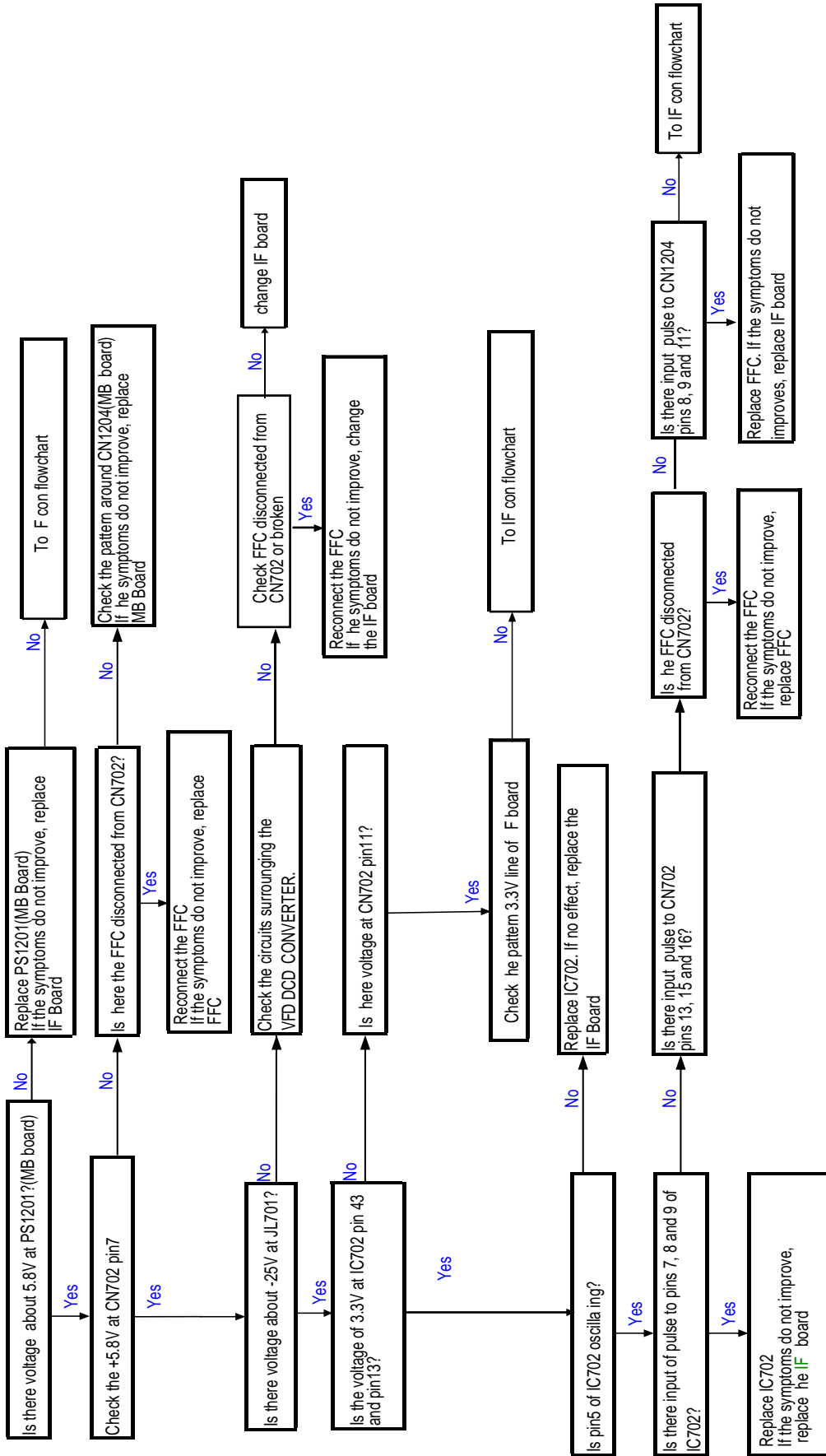

Remote control does not operate

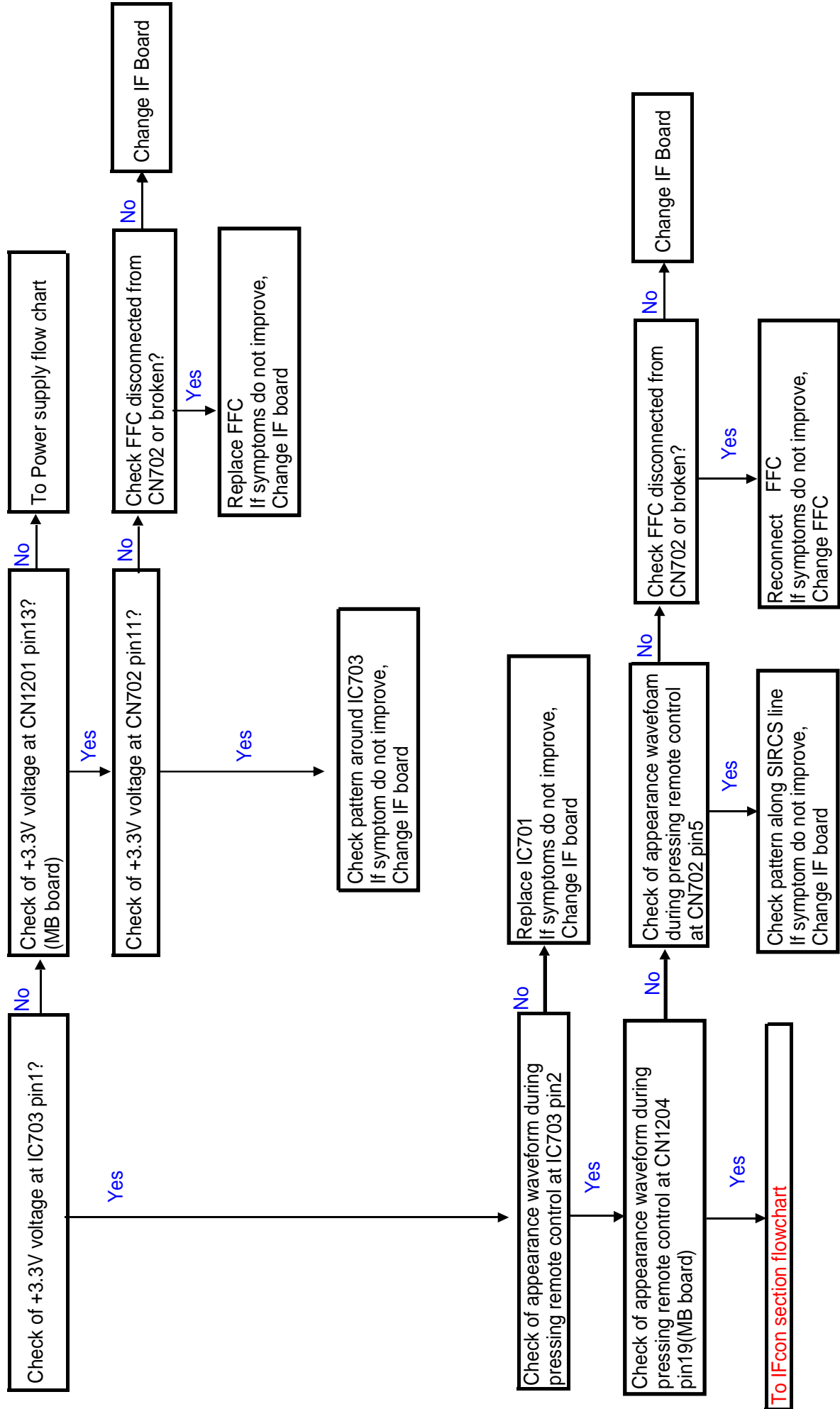

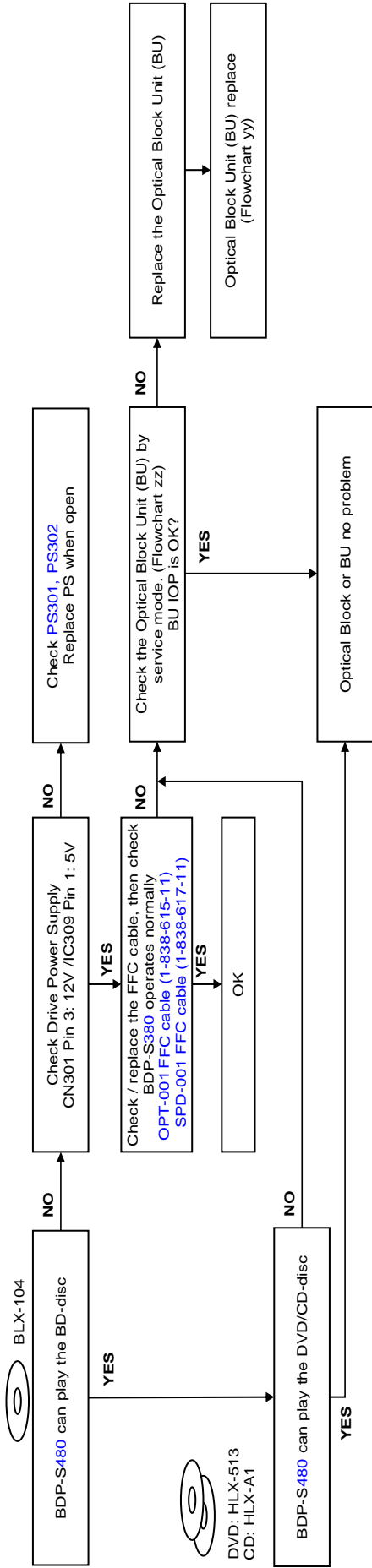

Optical Block Unit (BU) IOP check flow (zz) ~ [Before BU Replacement]

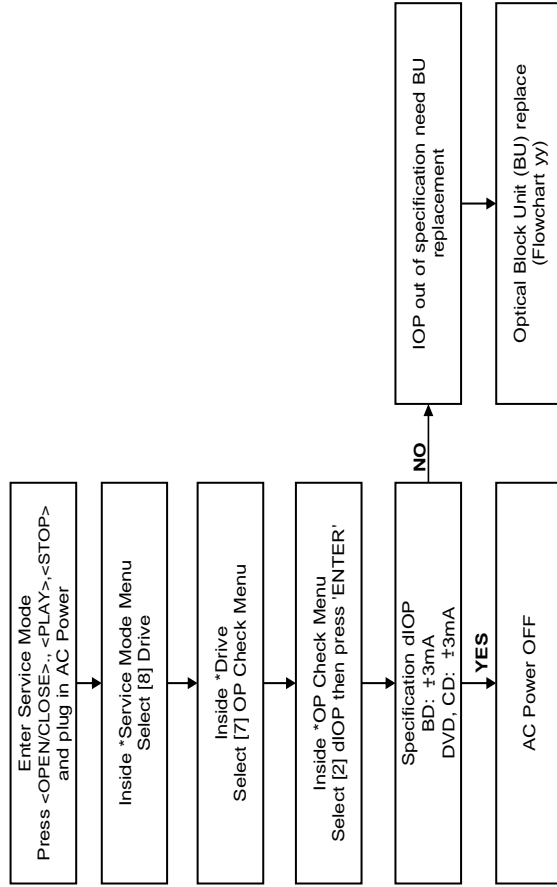

Optical Block Unit (BU) OP Data Write Flow (yy) ~ [After BU/MB Replacement]

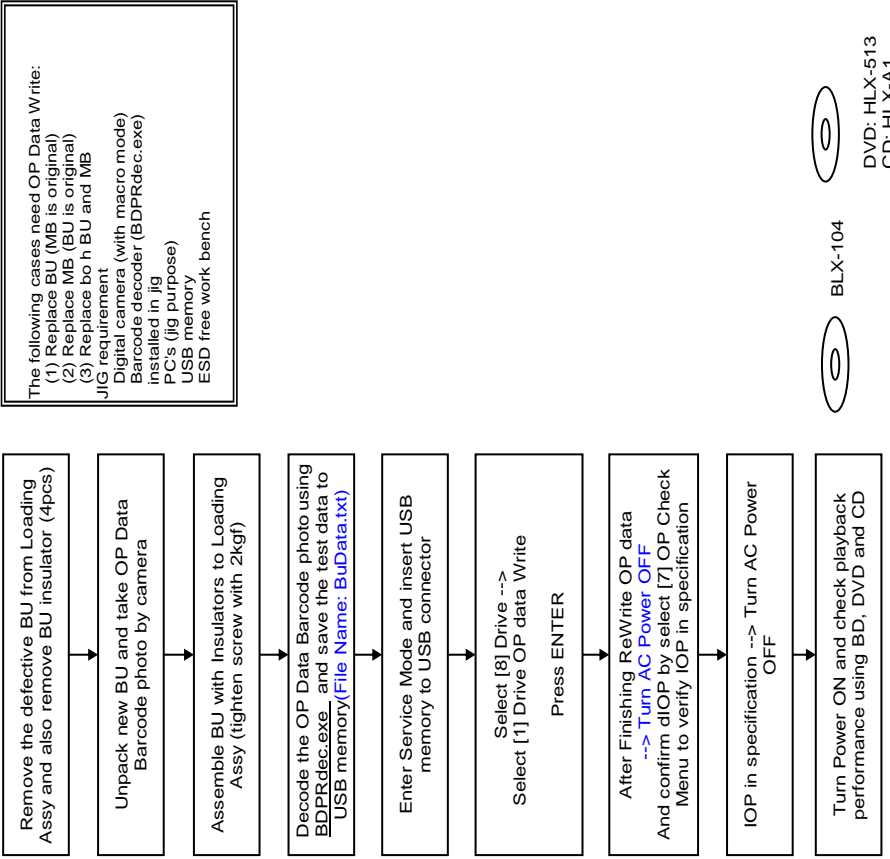

Fan flowchart

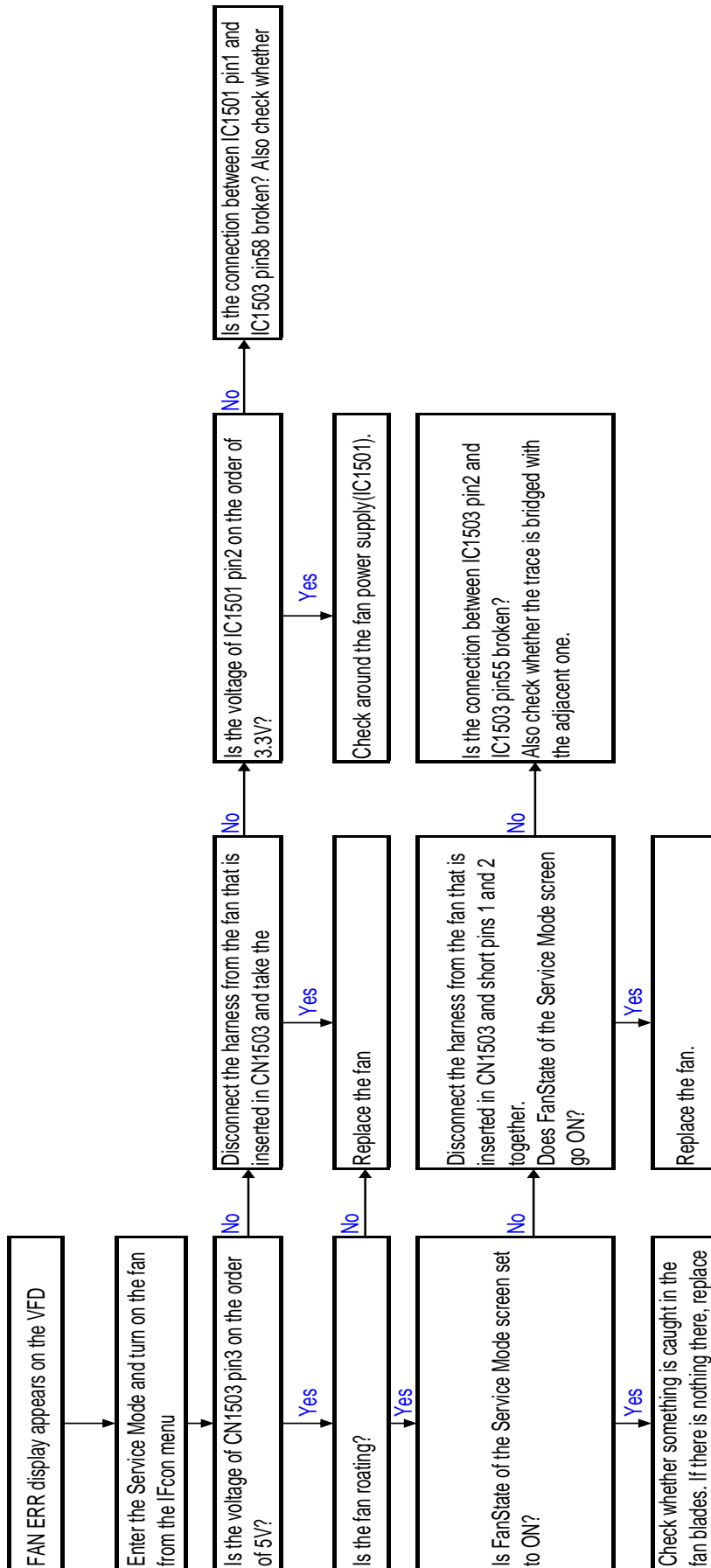

Ethernet flowchart

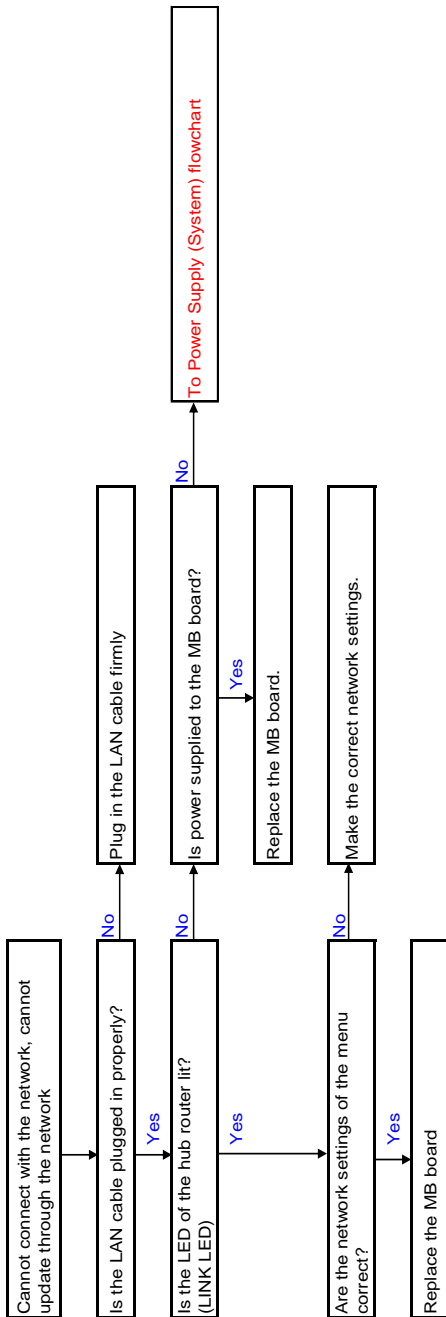

Wireless LAN Flowchart (BDP-S580/BX58 only)

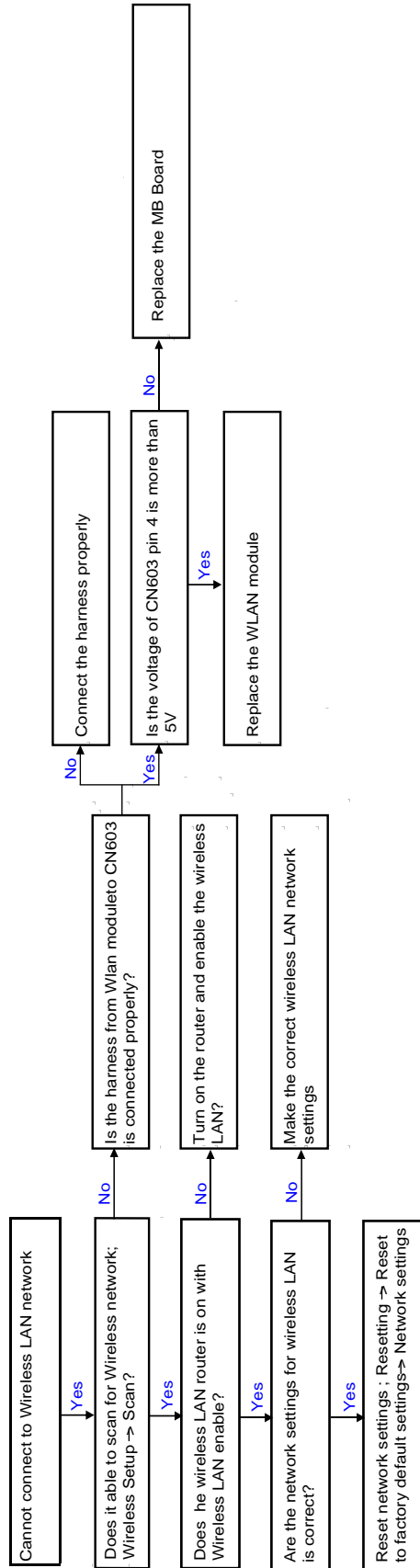

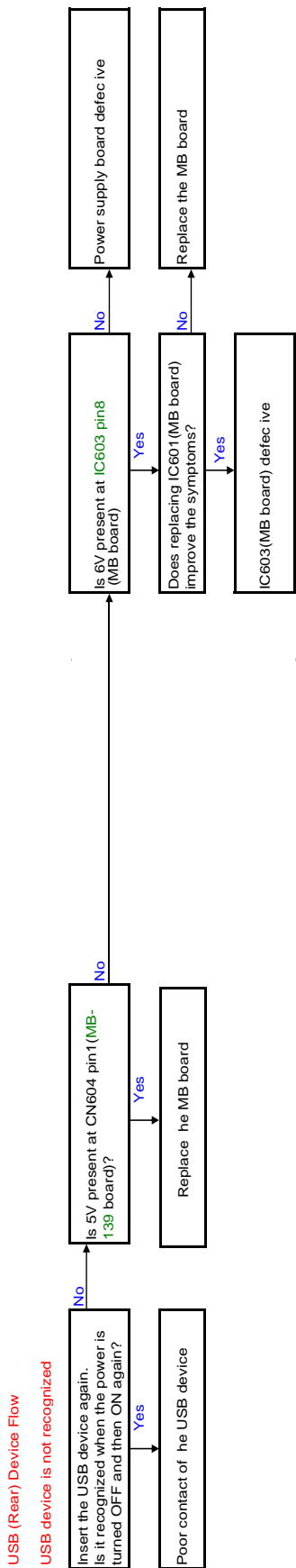

USB (Front) Device Flow (except BDP-S280)
 USB device is not recognized

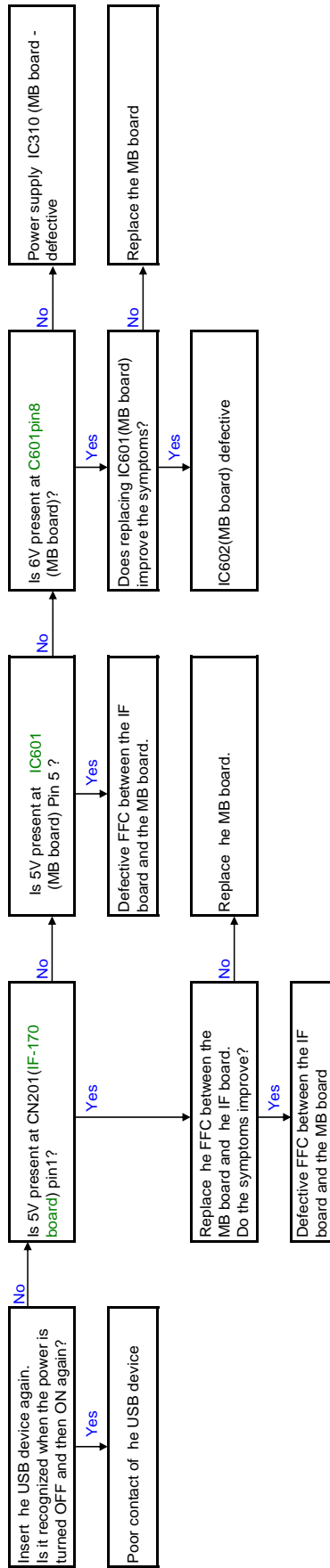

10-1-2. MAIN CHASSIS SECTION

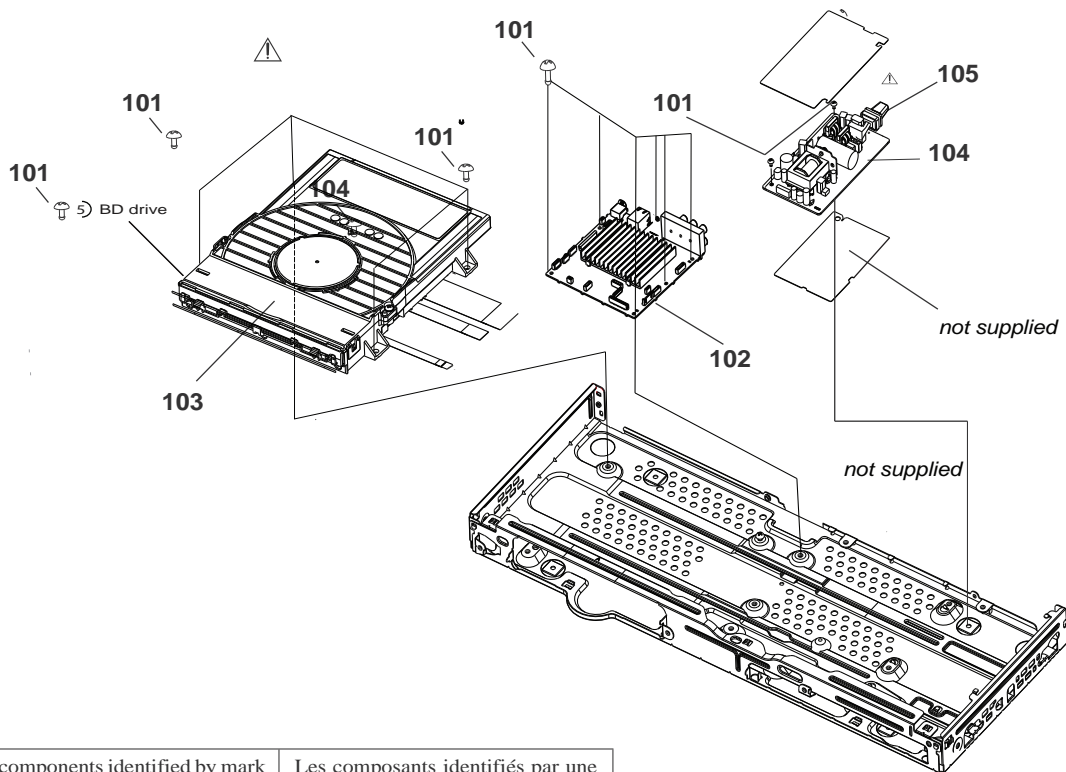

The components identified by mark \triangle or dotted line with mark \triangle are critical for safety. Replace only with part number specified.

Les composants identifiés par une marque \triangle sont critiques pour la sécurité. Ne les remplacer que par une pièce portant le numéro spécifié.

Ref. No.	Part No.	Description	Remark
$\hat{\triangle}$ 101	3-077-331-21	+BV3 (3-CR)	
$\hat{\triangle}$ 103	A-1750-926-A	LOADING FOR SERVICE	
$\hat{\triangle}$ 102	A-1800-696-A	SERVICE ASSY, MB	(BDP-S480:US)
$\hat{\triangle}$ 102	A-1800-933-A	SERVICE ASSY, MB	(BDP-S480:CND,UK,AEP,AUS,EA,KS)
$\hat{\triangle}$ 102	A-1801-097-A	SERVICE ASSY, MB	(BDP-S480:IN,E,AR,KR,TW/S483)
$\hat{\triangle}$ 102	A-1800-688-A	SERVICE ASSY, MB	(BDP-S580:US/BX58:US)
$\hat{\triangle}$ 102	A-1800-991-A	SERVICE ASSY, MB	(BDP-S580:CND,AEP,AUS,UK/BX58:CND)
$\hat{\triangle}$ 102	A-1801-118-A	SERVICE ASSY, MB	(BDP-S580:RUS)
$\hat{\triangle}$ 102	A-1816-121-A	SERVICE ASSY, MB	(BDP-S580:BR)
$\hat{\triangle}$ 102	A-1821-465-A	SERVICE ASSY, MB	(BDP-S480:BR)
\triangle 104	1-474-267-11	SWITCHING REGULATOR	(BDP-S480:EXCEPT US, CND)(BDP-S580:EXCEPT US, CND)
\triangle 104	1-474-265-11	SWITCHING REGULATOR	(BDP-S580:US, CND)(BX58:US, CND)
\triangle 105	1-828-845-21	POWER-SUPPLY CORD	(BDP-S480:TW)
\triangle 105	1-835-682-21	POWER-SUPPLY CORD	(BDP-S480:AR)
\triangle 105	1-835-683-21	POWER-SUPPLY CORD	(BDP-S480:E, AEP, EA)(BDP-S483:E)(BDP-S580:AEP, RUS)
\triangle 105	1-835-684-21	POWER-SUPPLY CORD	(BDP-S480:US, CND)(BDP-S580:US, CND)(BDP-BX58:US, CND)
\triangle 105	1-835-688-21	POWER-SUPPLY CORD	(BDP-S480:UK, KS)(BDP-S483:UK)(BDP-S580:UK)
\triangle 105	1-835-689-21	POWER-SUPPLY CORD	(BDP-S480:KR)
\triangle 105	1-835-093-11	POWER-SUPPLY CORD	(BDP-S480:E, AEP, EA)(BDP-S483:E)(BDP-S580:AEP, RUS)
\triangle 105	1-836-410-11	POWER-SUPPLY CORD	(BDP-S480:IN)
\triangle 105	1-835-690-22	POWER-SUPPLY CORD	(BDP-S480:AUS)
\triangle 105	1-837-073-11	POWER-SUPPLY CORD	(BDP-S480:BR)

10-1-3. BD SECTION

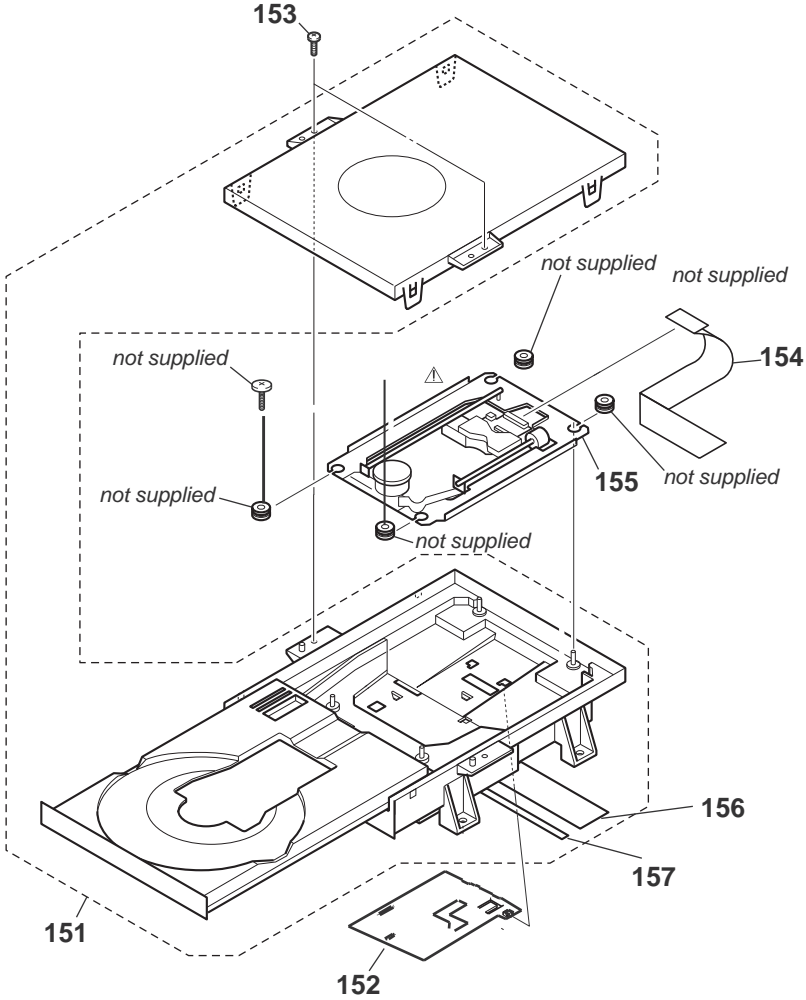

<p>The components identified by mark \triangle or dotted line with mark \triangle are critical for safety. Replace only with part number specified.</p>	<p>Les composants identifiés par une marque \triangle sont critiques pour la sécurité. Ne les remplacer que par une pièce portant le numéro spécifié.</p>
---	--

Ref. No	Part No.	Description	Remark
\triangle 151	A-1750-926-A	LOADING FOR SERVICE	
152	4-167-321-01	HOLDER, FFC (RIGHT)	
153	3-087-053-11	+BVTP2.6 (3CR)	
154	1-838-616-11	FLEXIBLE FLAT CABLE (LDG-001)	
154	1-838-615-11	FLEXIBLE FLAT CABLE (OPT-001)	
154	1-838-617-11	FLEXIBLE FLAT CABLE (SPD-001)	
\triangle 155	8-820-445-04	DEVICE,OPTICAL KEM-470AAA/C2NP	(BDP-S580:AEP, RUS, AUS)(BX58:US, CND)

10-1-4. ACCESSORIES

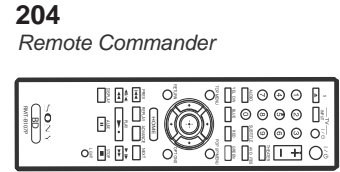
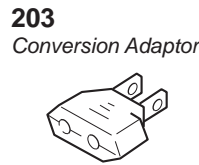
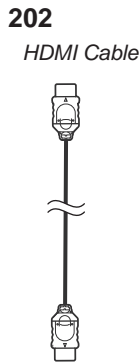
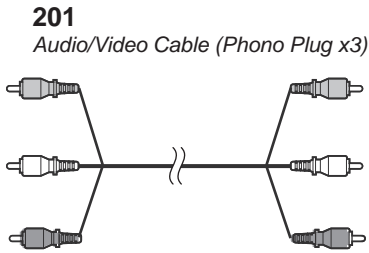

<p>The components identified by mark or dotted line with mark are critical for safety. Replace only with part number specified.</p>	<p>Les composants identifiés par une marque sont critiques pour la sécurité. Ne les remplacer que par une pièce portant le numéro spécifié.</p>
---	--

Ref. No.	Part No.	Description	Remark
201	1-751-271-71	CORD, CONNECTION (AV)	(BDP-S480:US, CND, KR, TW, AUS, EA, KS, IN) (BDP-S580:US, CND, RUS, AUS)(BDP-BX58:US, CND)
201	1-837-797-21	CORD, CONNECTION (AV)	(BDP-S480:US, CND, KR, TW, AUS, EA, KS, IN) (BDP-S580:US, CND, RUS, AUS)(BDP-BX58:US, CND)
201	1-834-169-22	CORD, CONNECTION (HDMI CABLE)	(BDP-S480:E, AR, KR, TW, EA, KS, IN)(BDP-S483:E)(BDP-BX58:US)
203	1-569-008-41	ADAPTOR, CONVERSION	(BDP-S480:E)(S483:E)
203	1-569-008-22	ADAPTOR, CONVERSION 2P	(BDP-S480:E)(S483:E)
204	1-489-399-11	REMOTE COMMANDER (RMT-B109A)	(BDP-S480:US, CND, E, AR, KR, TW)(BDP-S580:US, CND)
204	1-489-400-11	REMOTE COMMANDER (RMT-B109P)	(BDP-S480:UK, KS, IN)(BDP-S580:UK, AEP, RUS, AUS)
204	1-489-402-11	REMOTE COMMANDER (RMT-B110A)	(BDP-S483:UK)(BDP-BX-58:US, CND)
204	1-489-435-11	REMOTE COMMANDER (RMT-B110P)	(BDP-S483:E)
*	4-261-095-41	MANUAL, INSTRUCTION	(BDP-S480:KR) (KOREAN)
*	4-261-095-51	MANUAL, INSTRUCTION	(BDP-S480:TW) (CHINESE TRADITIONAL)
*	4-261-095-61	MANUAL, INSTRUCTION	(BDP-S480:EA, KS)(ENGLISH)
*	4-261-095-71	MANUAL, INSTRUCTION	(BDP-S480:EA, KS)(ARABIC)
	4-261-096-11	MANUAL, INSTRUCTION	(BDP-S480:UK, AUS, IN)(BDP-S483:UK)(S580:UK/S580:AUS) (ENGLISH)
*	4-261-096-21	MANUAL, INSTRUCTION	(BDP-S480:AEP)(BDP-S580:AEP)(FRENCH)
*	4-261-096-31	MANUAL, INSTRUCTION	(BDP-S480:AEP)(BDP-S580:AEP)(GERMAN)
*	4-261-096-41	MANUAL, INSTRUCTION	(BDP-S480:AEP)(BDP-S580:AEP)(ITALIAN)
*	4-261-096-51	MANUAL, INSTRUCTION	(BDP-S480:AEP)(BDP-S580:AEP) (DUTCH)
*	4-261-097-11	MANUAL, INSTRUCTION	(BDP-S480:AEP)(BDP-S580:AEP) (SPANISH)
*	4-261-097-21	MANUAL, INSTRUCTION	(BDP-S480:AEP)(BDP-S580:AEP) (PORTUGUESE)
*	4-261-097-31	MANUAL, INSTRUCTION	(BDP-S480:AEP)(BDP-S580:AEP) (SWEDISH)
*	4-261-097-41	MANUAL, INSTRUCTION	(BDP-S480:AEP)(BDP-S580:AEP) (DANISH)
*	4-261-097-51	MANUAL, INSTRUCTION	(BDP-S480:AEP)(BDP-S580:AEP) (FINNISH)
*	4-261-097-61	MANUAL, INSTRUCTION	(BDP-S580:RUS)(RUSSIAN)
*	4-261-097-71	MANUAL, INSTRUCTION	(BDP-S580:RUS)(UKRAINIAN)

FL-203

IF-170

10-2. ELECTRICAL PARTS LIST

NOTE:

The components identified by mark Δ or dotted line with mark Δ are critical for safety. Replace only with part number specified.

When indicating parts by reference number, please include the board.

The components identified by mark Δ contain confidential information. Strictly follow the instructions whenever the components are repaired and/or replaced.

Due to standardization, replacements in the

uA. . : μ A. . uPA. . : μ PA. .
 uPB. . : μ PB. . uPC. . : μ PC. .
 uPD. . : μ PD. .

used on the set.
 -XX and -X mean standardized parts, so

CAPACITORS

original one.

• COILS

RESISTORS

uH: μ H

All resistors are in ohms.

Abbreviation

Not all of the parts for SWITCHING REGULATOR are listed.

AEP : AEP Model
 AR : Argentina Model
 AUS : Australia New Zealand Model
 BR : Brazilian Model
 CND : Canadian Model
 E : Latin America Model
 EA : Middle East Model
 IN : India Model
 KS : Saudi Arabia Model

RUS : Russian Model
 KR : Korean Model
 TH : Thailand Model
 TW : Taiwan Model
 US : USA Model
 UK : UK Model

Items marked * are not stocked since they are seldom required for routine service.

Some delay should be anticipated when ordering these items.

SEMICONDUCTORS

In each case, u: μ , for example:

A-1816-123-A	SERVICE ASSY, FL (BDP-S480: BR/S580: BR)				<IC>
A-1800-284-A	SERVICE ASSY, FL (BDP-S480:EXCEPT BR/S483 /S580:EXCEPT BR)		IC702	6-701-729-01	IC PT6315
			* IC703	6-600-626-01	IC GP1UW254GKC1

<JUMPER RESISTOR>

Ref-No.	Part No.	Part Description E
CN331	1-564-012-11	PIN, CONNECTOR 2P
S331	1-771-874-11	SWITCH, TACTILE

JR701	1-216-295-91	SHORT CHIP	0
JR702	1-216-295-91	SHORT CHIP	0
JR703	1-216-295-91	SHORT CHIP	0
JR704	1-216-296-91	SHORT CHIP	0
JR705	1-216-296-91	SHORT CHIP	0

A-1816-122-A	SERVICE ASSY, IF (BDP-S580:BR)	JR706	1-216-296-91	SHORT CHIP	0
A-1821-466-A	SERVICE ASSY, IF (BDP-S480:BR)	JR707	1-216-296-91	SHORT CHIP	0
A-1800-283-A	SERVICE ASSY, IF (BDP-S480:EXCEPT BR/S483)	JR708	1-216-296-91	SHORT CHIP	0
A-1800-690-A	SERVICE ASSY, IF (BDP-S580:EXCEPT BR/BX58)	JR709	1-216-296-91	SHORT CHIP	0
		JR710	1-216-296-91	SHORT CHIP	0
		JR711	1-216-296-91	SHORT CHIP	0
		JR712	1-216-295-91	SHORT CHIP	0
		JR714	1-216-296-91	SHORT CHIP	0
		JR715	1-216-296-91	SHORT CHIP	0
		JR716	1-216-295-91	SHORT CHIP	0

Ref-No.	Part No.	Part Description E
---------	----------	--------------------

<CAPACITOR>

* C201	1-112-298-91	CERAMIC CHIP 1UF	10%	16V	JR717	1-216-295-91	SHORT CHIP	0
C202	1-162-910-91	CERAMIC CHIP 5PF	0.25PF	50V	JR718	1-216-296-91	SHORT CHIP	0
C203	1-162-910-91	CERAMIC CHIP 5PF	0.25PF	50V	JR719	1-216-296-91	SHORT CHIP	0
C703	1-125-972-91	ELECT 100UF	20.00%	16V	JR720	1-216-296-91	SHORT CHIP	0
C704	1-124-236-91	ELECT 47UF	20.00%	16V	JR721	1-216-296-91	SHORT CHIP	0
C707	1-107-726-91	CERAMIC CHIP 0.01UF	10.00%	16V	JR722	1-216-295-91	SHORT CHIP	0
C712	1-128-131-91	ELECT 22UF	20.00%	50V	JR723	1-216-295-91	SHORT CHIP	0
C714	1-107-726-91	CERAMIC CHIP 0.01UF	10.00%	16V	JR724	1-216-296-91	SHORT CHIP	0
C715	1-107-726-91	CERAMIC CHIP 0.01UF	10.00%	16V	JR726	1-216-295-91	SHORT CHIP	0
C719	1-163-015-91	CERAMIC CHIP 0.0033UF	10.00%	50V	JR728	1-216-296-91	SHORT CHIP	0

C720	1-163-015-91	CERAMIC CHIP 0.0033UF	10.00%	50V	L702	1-414-857-51	<INDUCTOR> INDUCTOR	100UH
------	--------------	-----------------------	--------	-----	------	--------------	------------------------	-------

<CONNECTOR>

CN201	1-842-603-11	USB CONNECTOR (A)			ND701	1-483-325-11	<DISPLAY> VACUUM FLUORESCENT DISPLAYS
-------	--------------	-------------------	--	--	-------	--------------	--

<DIODE>

D705	6-502-961-01	DI DA2J10100L			Q706	6-552-056-01	<TRANSISTOR> TR 2SC6046-T112-1W
D706	6-502-961-01	DI DA2J10100L			Q707	6-552-056-01	TR 2SC6046-T112-1W
D709	6-503-465-01	DI 1L034XW34A0CT501			Q709	6-552-056-01	TR 2SC6046-T112-1W

IF170

MB-139

Ref-No.	Part No.	Part Description	Remarks	Ref-No.	Part No.	Part Description	Remarks
		<RESISTOR>					
R201	1-216-295-91	SHORT CHIP	0	C134	1-100-916-11	CERAMIC CHIP 0.1UF	10% 16V
R202	1-216-864-91	SHORT CHIP	0	C135	1-100-916-11	CERAMIC CHIP 0.1UF	10% 16V
R203	1-216-864-91	SHORT CHIP	0	C136	1-100-916-11	CERAMIC CHIP 0.1UF	10% 16V
R704	1-216-864-91	SHORT CHIP	0	C138	1-100-916-11	CERAMIC CHIP 0.1UF	10% 16V
R708	1-216-805-91	METAL CHIP	47 5% 1/10W	C141	1-100-909-11	CERAMIC CHIP 10UF	10% 6.3V
R714	1-216-839-91	METAL CHIP	33K 5% 1/10W	C142	1-112-777-11	CERAMIC CHIP 0.01UF	10% 25V
R715	1-216-845-91	METAL CHIP	100K 5% 1/10W	C143	1-112-777-11	CERAMIC CHIP 0.01UF	10% 25V
R717	1-216-809-91	METAL CHIP	100 5% 1/10W	C144	1-114-130-11	CERAMIC CHIP 1UF	10% 6.3V
R718	1-216-829-91	METAL CHIP	4.7K 5% 1/10W	C145	1-100-916-11	CERAMIC CHIP 0.1UF	10% 16V
R726	1-216-829-91	METAL CHIP	4.7K 5% 1/10W	C148	1-114-130-11	CERAMIC CHIP 1UF	10% 6.3V
		<SWITCH>					
S701	1-692-431-21	SWITCH, TACTILE		C149	1-114-130-11	CERAMIC CHIP 1UF	10% 6.3V
S702	1-692-431-21	SWITCH, TACTILE		C150	1-100-916-11	CERAMIC CHIP 0.1UF	10% 16V
S703	1-692-431-21	SWITCH, TACTILE		C152	1-114-130-11	CERAMIC CHIP 1UF	10% 6.3V
		<TRANSFORMER>		C154	1-114-130-11	CERAMIC CHIP 1UF	10% 6.3V
* T701	1-445-782-11	DC-DC CONVERTER TRANSFORMER		C156	1-112-777-11	CERAMIC CHIP 0.01UF	10% 25V
		[REDACTED]		C157	1-100-916-11	CERAMIC CHIP 0.1UF	10% 16V
	Ⓐ A-1816-121-A	SERVICE ASSY, MB	(BDP-S580:BR)	C159	1-112-777-11	CERAMIC CHIP 0.01UF	10% 25V
	Ⓐ A-1821-465-A	SERVICE ASSY, MB	(BDP-S480:BR)	C160	1-100-916-11	CERAMIC CHIP 0.1UF	10% 16V
	Ⓐ A-1800-696-A	SERVICE ASSY, MB	(BDP-S480:US)	C170	1-100-909-11	CERAMIC CHIP 10UF	10% 6.3V
	Ⓐ A-1800-933-A	SERVICE ASSY, MB	(BDP-S480:CND,UK,AEP,AUS,EA,KS)	C201	1-100-916-11	CERAMIC CHIP 0.1UF	10% 16V
	Ⓐ A-1801-097-A	SERVICE ASSY, MB	(BDP-S480:IN,E,AR,KR,TW/S483)	C202	1-114-130-11	CERAMIC CHIP 1UF	10% 6.3V
	Ⓐ A-1800-688-A	SERVICE ASSY, MB	(BDP-S580:US/BX58:US)	C203	1-112-777-11	CERAMIC CHIP 0.01UF	10% 25V
	Ⓐ A-1800-991-A	SERVICE ASSY, MB	(BDP-S580:CND,AEP,AUS,UK/BX58:CND)	C204	1-100-916-11	CERAMIC CHIP 0.1UF	10% 16V
	Ⓐ A-1801-118-A	SERVICE ASSY, MB	(BDP-S580:RUS)	C205	1-100-916-11	CERAMIC CHIP 0.1UF	10% 16V
		*****		C207	1-100-916-11	CERAMIC CHIP 0.1UF	10% 16V
C103	1-100-916-11	CERAMIC CHIP 0.1UF	10% 16V	C208	1-100-916-11	CERAMIC CHIP 0.1UF	10% 16V
C104	1-100-916-11	CERAMIC CHIP 0.1UF	10% 16V	C209	1-100-916-11	CERAMIC CHIP 0.1UF	10% 16V
C105	1-100-916-11	CERAMIC CHIP 0.1UF	10% 16V	C212	1-112-777-11	CERAMIC CHIP 0.01UF	10% 25V
C106	1-100-916-11	CERAMIC CHIP 0.1UF	10% 16V	C214	1-100-916-11	CERAMIC CHIP 0.1UF	10% 16V
C107	1-100-916-11	CERAMIC CHIP 0.1UF	10% 16V	C215	1-100-909-11	CERAMIC CHIP 10UF	10% 6.3V
C108	1-100-916-11	CERAMIC CHIP 0.1UF	10% 16V	C216	1-100-916-11	CERAMIC CHIP 0.1UF	10% 16V
C109	1-100-916-11	CERAMIC CHIP 0.1UF	10% 16V	C217	1-100-916-11	CERAMIC CHIP 0.1UF	10% 16V
C110	1-100-916-11	CERAMIC CHIP 0.1UF	10% 16V	C218	1-100-916-11	CERAMIC CHIP 0.1UF	10% 16V
C111	1-100-916-11	CERAMIC CHIP 0.1UF	10% 16V	C219	1-112-777-11	CERAMIC CHIP 0.01UF	10% 25V
C112	1-100-916-11	CERAMIC CHIP 0.1UF	10% 16V	C220	1-100-916-11	CERAMIC CHIP 0.1UF	10% 16V
C113	1-100-916-11	CERAMIC CHIP 0.1UF	10% 16V	C221	1-100-916-11	CERAMIC CHIP 0.1UF	10% 16V
C114	1-100-916-11	CERAMIC CHIP 0.1UF	10% 16V	C222	1-114-130-11	CERAMIC CHIP 1UF	10% 6.3V
C116	1-100-916-11	CERAMIC CHIP 0.1UF	10% 16V	C223	1-100-916-11	CERAMIC CHIP 0.1UF	10% 16V
C117	1-114-130-11	CERAMIC CHIP 1UF	10% 6.3V	C224	1-100-916-11	CERAMIC CHIP 0.1UF	10% 16V
C118	1-100-916-11	CERAMIC CHIP 0.1UF	10% 16V	C226	1-100-916-11	CERAMIC CHIP 0.1UF	10% 16V
C119	1-100-916-11	CERAMIC CHIP 0.1UF	10% 16V	C227	1-112-777-11	CERAMIC CHIP 0.01UF	10% 25V
C120	1-100-916-11	CERAMIC CHIP 0.1UF	10% 16V	C228	1-100-909-11	CERAMIC CHIP 10UF	10% 6.3V
C121	1-100-916-11	CERAMIC CHIP 0.1UF	10% 16V	C229	1-100-916-11	CERAMIC CHIP 0.1UF	10% 16V
C122	1-100-916-11	CERAMIC CHIP 0.1UF	10% 16V	C230	1-112-777-11	CERAMIC CHIP 0.01UF	10% 25V
C123	1-112-777-11	CERAMIC CHIP 0.01UF	10% 25V	C231	1-112-777-11	CERAMIC CHIP 0.01UF	10% 25V
C125	1-100-916-11	CERAMIC CHIP 0.1UF	10% 16V	C232	1-112-777-11	CERAMIC CHIP 0.01UF	10% 25V
C126	1-114-130-11	CERAMIC CHIP 1UF	10% 6.3V	C233	1-112-777-11	CERAMIC CHIP 0.01UF	10% 25V
C127	1-100-916-11	CERAMIC CHIP 0.1UF	10% 16V	C236	1-100-916-11	CERAMIC CHIP 0.1UF	10% 16V
C128	1-100-909-11	CERAMIC CHIP 10UF	10% 6.3V	C237	1-114-130-11	CERAMIC CHIP 1UF	10% 6.3V
C129	1-100-916-11	CERAMIC CHIP 0.1UF	10% 16V	C239	1-114-130-11	CERAMIC CHIP 1UF	10% 6.3V
C131	1-100-916-11	CERAMIC CHIP 0.1UF	10% 16V	C240	1-114-130-11	CERAMIC CHIP 1UF	10% 6.3V
C133	1-112-777-11	CERAMIC CHIP 0.01UF	10% 25V	C242	1-114-130-11	CERAMIC CHIP 1UF	10% 6.3V
				C243	1-100-916-11	CERAMIC CHIP 0.1UF	10% 16V
				C244	1-100-916-11	CERAMIC CHIP 0.1UF	10% 16V
				C245	1-100-909-11	CERAMIC CHIP 10UF	10% 6.3V

BDP-BX58/S480/S483/S580

<u>Ref.No.</u>	<u>Part No.</u>	<u>Part Description</u>	<u>Remarks</u>	<u>Ref.No.</u>	<u>Part No.</u>	<u>Part Description</u>	<u>Remarks</u>
C306	1-112-298-91	CERAMIC CHIP 1UF	10% 16V	C443	1-100-916-11	CERAMIC CHIP 0.1UF	10% 16V
C307	1-112-777-11	CERAMIC CHIP 0.01UF	10% 25V	C446	1-164-850-81	CERAMIC CHIP 10PF	0.50PF 50V
C308	1-112-777-11	CERAMIC CHIP 0.01UF	10% 25V	C447	1-164-852-81	CERAMIC CHIP 12PF	5.00% 50V
C309	1-165-908-91	CERAMIC CHIP 1UF	10% 10V	C448	1-100-916-11	CERAMIC CHIP 0.1UF	10% 16V
C310	1-100-909-11	CERAMIC CHIP 10UF	10% 6.3V	C450	1-100-916-11	CERAMIC CHIP 0.1UF	10% 16V
C311	1-100-966-91	CERAMIC CHIP 10UF	20% 10V	C454	1-100-916-11	CERAMIC CHIP 0.1UF	10% 16V
C314	1-165-908-91	CERAMIC CHIP 1UF	10% 10V	C457	1-162-910-91	CERAMIC CHIP 5PF	0.25PF 50V
C317	1-165-908-91	CERAMIC CHIP 1UF	10% 10V			S480/S483	
C318	1-100-159-91	CERAMIC CHIP 22UF	10% 6.3V	C457	1-216-864-91	SHORT CHIP 0	
C321	1-114-553-11	CERAMIC CHIP 10UF	10% 16V			S580/BX58/BR4	
C323	1-112-777-11	CERAMIC CHIP 0.01UF	10% 25V	C458	1-162-910-91	CERAMIC CHIP 5PF	0.25PF 50V
C327	1-165-908-91	CERAMIC CHIP 1UF	10% 10V	C459	1-162-910-91	CERAMIC CHIP 5PF	0.25PF 50V
C330	1-112-815-91	CERAMIC CHIP 10UF	20% 6.3V	C460	1-162-910-91	CERAMIC CHIP 5PF	0.25PF 50V
C331	1-112-778-11	CERAMIC CHIP 0.022UF	10% 25V	C504	1-100-916-11	CERAMIC CHIP 0.1UF	10% 16V
C332	1-165-908-91	CERAMIC CHIP 1UF	10% 10V	C507	1-100-916-11	CERAMIC CHIP 0.1UF	10% 16V
C335	1-165-908-91	CERAMIC CHIP 1UF	10% 10V	C605	1-165-908-91	CERAMIC CHIP 1UF	10% 10V
C336	1-100-916-11	CERAMIC CHIP 0.1UF	10% 16V	C606	1-100-909-11	CERAMIC CHIP 10UF	10% 6.3V
C337	1-100-159-91	CERAMIC CHIP 22UF	10% 6.3V	C608	1-100-909-11	CERAMIC CHIP 10UF	10% 6.3V
C338	1-100-159-91	CERAMIC CHIP 22UF	10% 6.3V	C611	1-165-908-91	CERAMIC CHIP 1UF	10% 10V
C340	1-114-553-11	CERAMIC CHIP 10UF	10% 16V	C616	1-128-394-21	ELECT CHIP 220UF	20% 10V
C341	1-114-553-11	CERAMIC CHIP 10UF	10% 16V	C617	1-165-908-91	CERAMIC CHIP 1UF	10% 10V
C343	1-114-553-11	CERAMIC CHIP 10UF	10% 16V	C619	1-165-908-91	CERAMIC CHIP 1UF	10% 10V
C346	1-112-777-11	CERAMIC CHIP 0.01UF	10% 25V	C620	1-128-394-21	ELECT CHIP 220UF	20% 10V
C347	1-165-908-91	CERAMIC CHIP 1UF	10% 10V	C621	1-112-300-91	CERAMIC CHIP 4.7UF	10% 10V
C348	1-114-802-11	CERAMIC CHIP 0.0033UF	10% 50V			S580/BX58/BR4	
C349	1-100-916-11	CERAMIC CHIP 0.1UF	10% 16V	C623	1-112-300-91	CERAMIC CHIP 4.7UF	10% 10V
C350	1-100-916-11	CERAMIC CHIP 0.1UF	10% 16V			S580/BX58/BR4	
C351	1-100-159-91	CERAMIC CHIP 22UF	10% 6.3V	C625	1-164-850-81	CERAMIC CHIP 10PF	0.50PF 50V
C352	1-100-159-91	CERAMIC CHIP 22UF	10% 6.3V	C628	1-164-850-81	CERAMIC CHIP 10PF	0.50PF 50V
C353	1-100-159-91	CERAMIC CHIP 22UF	10% 6.3V	C631	1-100-966-91	CERAMIC CHIP 10UF	20% 10V
C365	1-114-553-11	CERAMIC CHIP 10UF	10% 16V	C632	1-100-966-91	CERAMIC CHIP 10UF	20% 10V
C366	1-100-916-11	CERAMIC CHIP 0.1UF	10% 16V	C702	1-100-916-11	CERAMIC CHIP 0.1UF	10% 16V
C367	1-100-905-11	CERAMIC CHIP 0.001UF	10% 50V	C713	1-115-467-91	CERAMIC CHIP 0.22UF	10.00% 10V
C369	1-112-777-11	CERAMIC CHIP 0.01UF	10% 25V	C715	1-115-467-91	CERAMIC CHIP 0.22UF	10.00% 10V
C371	1-114-553-11	CERAMIC CHIP 10UF	10% 16V	C716	1-112-777-11	CERAMIC CHIP 0.01UF	10% 25V
C373	1-112-777-11	CERAMIC CHIP 0.01UF	10% 25V	C717	1-115-467-91	CERAMIC CHIP 0.22UF	10.00% 10V
C377	1-165-908-91	CERAMIC CHIP 1UF	10% 10V	C719	1-112-777-11	CERAMIC CHIP 0.01UF	10% 25V
C379	1-112-777-11	CERAMIC CHIP 0.01UF	10% 25V	C720	1-115-467-91	CERAMIC CHIP 0.22UF	10.00% 10V
C381	1-165-908-91	CERAMIC CHIP 1UF	10% 10V	C723	1-100-916-11	CERAMIC CHIP 0.1UF	10% 16V
C382	1-112-777-11	CERAMIC CHIP 0.01UF	10% 25V	C726	1-100-916-11	CERAMIC CHIP 0.1UF	10% 16V
C383	1-114-553-11	CERAMIC CHIP 10UF	10% 16V	C728	1-100-916-11	CERAMIC CHIP 0.1UF	10% 16V
C403	1-100-916-11	CERAMIC CHIP 0.1UF	10% 16V	C801	1-100-916-11	CERAMIC CHIP 0.1UF	10% 16V
C405	1-112-777-11	CERAMIC CHIP 0.01UF	10% 25V	C808	1-114-130-11	CERAMIC CHIP 1UF	10% 6.3V
C415	1-100-909-11	CERAMIC CHIP 10UF	10% 6.3V	C809	1-114-130-11	CERAMIC CHIP 1UF	10% 6.3V
C417	1-100-916-11	CERAMIC CHIP 0.1UF	10% 16V	C810	1-100-916-11	CERAMIC CHIP 0.1UF	10% 16V
C422	1-100-916-11	CERAMIC CHIP 0.1UF	10% 16V	C811	1-100-916-11	CERAMIC CHIP 0.1UF	10% 16V
C423	1-100-909-11	CERAMIC CHIP 10UF	10% 6.3V	C827	1-100-916-11	CERAMIC CHIP 0.1UF	10% 16V
C424	1-100-916-11	CERAMIC CHIP 0.1UF	10% 16V	C907	1-100-916-11	CERAMIC CHIP 0.1UF	10% 16V
C425	1-100-916-11	CERAMIC CHIP 0.1UF	10% 16V	C918	1-100-916-11	CERAMIC CHIP 0.1UF	10% 16V
C426	1-100-916-11	CERAMIC CHIP 0.1UF	10% 16V	C923	1-165-908-91	CERAMIC CHIP 1UF	10% 10V
C428	1-100-916-11	CERAMIC CHIP 0.1UF	10% 16V	C926	1-100-916-11	CERAMIC CHIP 0.1UF	10% 16V
C429	1-100-916-11	CERAMIC CHIP 0.1UF	10% 16V	C932	1-114-130-11	CERAMIC CHIP 1UF	10% 6.3V
C430	1-100-916-11	CERAMIC CHIP 0.1UF	10% 16V	C933	1-114-869-11	CERAMIC CHIP 2.2UF	10% 6.3V
C431	1-100-916-11	CERAMIC CHIP 0.1UF	10% 16V	C938	1-112-775-11	CERAMIC CHIP 0.0022UF	10% 50V
C440	1-100-916-11	CERAMIC CHIP 0.1UF	10% 16V	C939	1-112-775-11	CERAMIC CHIP 0.0022UF	10% 50V
				C946	1-164-862-81	CERAMIC CHIP 33PF	5.00% 50V

Ref.No.	Part No.	Part Description	Remarks	Ref.No.	Part No.	Part Description	Remarks
C1001	1-128-994-21	ELECT CHIP 47UF	20% 10V	C2402	1-100-916-11	CERAMIC CHIP 0.1UF	10% 16V
C1002	1-100-916-11	CERAMIC CHIP 0.1UF	10% 16V	* C2404	1-112-298-91	CERAMIC CHIP 1UF	10% 16V
C1012	1-100-916-11	CERAMIC CHIP 0.1UF	10% 16V	C2405	1-117-681-21	ELECT CHIP 100UF	20.00% 16V
C1014	1-128-994-21	ELECT CHIP 47UF	20% 10V	C2406	1-112-777-11	CERAMIC CHIP 0.01UF	10% 25V
C1017	1-100-966-91	CERAMIC CHIP 10UF	20% 10V	C2412	1-117-681-21	ELECT CHIP 100UF	20.00% 16V
C1022	1-100-916-11	CERAMIC CHIP 0.1UF	10% 16V	C2426	1-112-777-11	CERAMIC CHIP 0.01UF	10% 25V
C1023	1-100-916-11	CERAMIC CHIP 0.1UF	10% 16V	C2432	1-112-777-11	CERAMIC CHIP 0.01UF	10% 25V
C1024	1-114-130-11	CERAMIC CHIP 1UF	10% 6.3V	C2433	1-112-777-11	CERAMIC CHIP 0.01UF	10% 25V
C1025	1-114-130-11	CERAMIC CHIP 1UF	10% 6.3V	* C2438	1-112-298-91	CERAMIC CHIP 1UF	10% 16V
C1208	1-100-916-11	CERAMIC CHIP 0.1UF	10% 16V	C2439	1-112-777-11	CERAMIC CHIP 0.01UF	10% 25V
C1209	1-100-916-11	CERAMIC CHIP 0.1UF	10% 16V	C2440	1-100-916-11	CERAMIC CHIP 0.1UF	10% 16V
C1210	1-100-916-11	CERAMIC CHIP 0.1UF	10% 16V	C2441	1-112-777-11	CERAMIC CHIP 0.01UF	10% 25V
C1213	1-100-916-11	CERAMIC CHIP 0.1UF	10% 16V	C2450	1-100-916-11	CERAMIC CHIP 0.1UF	10% 16V
C1214	1-100-916-11	CERAMIC CHIP 0.1UF	10% 16V	* C2454	1-112-298-91	CERAMIC CHIP 1UF	10% 16V
C1216	1-100-916-11	CERAMIC CHIP 0.1UF	10% 16V	C2460	1-100-916-11	CERAMIC CHIP 0.1UF	10% 16V
C1218	1-112-777-11	CERAMIC CHIP 0.01UF	10% 25V	C2470	1-100-916-11	CERAMIC CHIP 0.1UF	10% 16V
C1219	1-100-916-11	CERAMIC CHIP 0.1UF	10% 16V	* C2481	1-112-298-91	CERAMIC CHIP 1UF	10% 16V
C1229	1-100-909-11	CERAMIC CHIP 10UF	10% 6.3V	* C2486	1-112-298-91	CERAMIC CHIP 1UF	10% 16V
C1301	1-100-916-11	CERAMIC CHIP 0.1UF	10% 16V	* C2495	1-112-298-91	CERAMIC CHIP 1UF	10% 16V
C1302	1-100-905-11	CERAMIC CHIP 0.001UF	10% 50V				
C1305	1-100-916-11	CERAMIC CHIP 0.1UF	10% 16V	CN301	1-506-472-11	<CONNECTOR> PIN, CONNECTOR 7P	
C1306	1-100-905-11	CERAMIC CHIP 0.001UF	10% 50V	CN604	1-842-128-11	USB CONNECTOR	
C1310	1-100-916-11	CERAMIC CHIP 0.1UF	10% 16V	CN701	1-820-735-31	HDMI CONNECTOR	
C1312	1-100-916-11	CERAMIC CHIP 0.1UF	10% 16V	CN801	1-819-875-31	ETHERNET CONNECTOR (8P)	
C1318	1-100-916-11	CERAMIC CHIP 0.1UF	10% 16V	CN1101	1-779-336-51	CONNECTOR, FFC/FPC 24P S580:BR4	
C1322	1-100-916-11	CERAMIC CHIP 0.1UF	10% 16V				
C1323	1-100-916-11	CERAMIC CHIP 0.1UF	10% 16V	CN1102	1-573-806-21	PIN, CONNECTOR (1.5MM) (SMD)6P	
C1325	1-100-916-11	CERAMIC CHIP 0.1UF	10% 16V	CN1202	1-764-177-21	PIN, CONNECTOR (SMD)(1.5MM) 7P	
C1326	1-100-916-11	CERAMIC CHIP 0.1UF	10% 16V	* CN1203	1-695-320-21	PIN, CONNECTOR (1.5MM)(SMD) 2P	
C1329	1-100-916-11	CERAMIC CHIP 0.1UF	10% 16V	CN1204	1-820-121-51	CONNECTOR, FFC/FPC 23P	
				* CN1503	1-695-320-21	PIN, CONNECTOR (1.5MM)(SMD) 2P	
C1334	1-100-916-11	CERAMIC CHIP 0.1UF	10% 16V				
C1357	1-137-765-21	ELECT CHIP 47UF	20% 16V				
* C1362	1-112-298-91	CERAMIC CHIP 1UF	10% 16V	D302	6-502-966-01	<DIODE> DI DZ2J056M0L	
C1363	1-100-916-11	CERAMIC CHIP 0.1UF	10% 16V	D303	6-502-248-01	DI KDZTR3.9B	
* C1365	1-112-298-91	CERAMIC CHIP 1UF	10% 16V	D304	6-502-248-01	DI KDZTR3.9B	
				D305	6-500-220-01	DIODE RB161M-20TR	
C1366	1-100-916-11	CERAMIC CHIP 0.1UF	10% 16V	D312	6-502-966-01	DI DZ2J056M0L	
C1373	1-112-777-11	CERAMIC CHIP 0.01UF	10% 25V				
* C1374	1-112-298-91	CERAMIC CHIP 1UF	10% 16V	D601	6-502-961-01	DI DA2J10100L	
C1375	1-112-777-11	CERAMIC CHIP 0.01UF	10% 25V	D602	6-502-961-01	DI DA2J10100L	
* C1376	1-112-298-91	CERAMIC CHIP 1UF	10% 16V				
C1377	1-112-777-11	CERAMIC CHIP 0.01UF	10% 25V	FB703	1-469-112-21	<FERRITE BEAD> FERRITE 0UH	
C1378	1-112-777-11	CERAMIC CHIP 0.01UF	10% 25V	FB704	1-469-112-21	FERRITE 0UH	
C1387	1-112-777-11	CERAMIC CHIP 0.01UF	10% 25V	FB705	1-469-112-21	FERRITE 0UH	
C1390	1-100-916-11	CERAMIC CHIP 0.1UF	10% 16V	FB706	1-469-112-21	FERRITE 0UH	
C1400	1-112-777-11	CERAMIC CHIP 0.01UF	10% 25V	FB901	1-400-940-21	FERRITE 0UH	
C1405	1-117-681-21	ELECT CHIP 100UF	20.00% 16V	FB1361	1-216-864-91	SHORT CHIP 0	
C1412	1-117-681-21	ELECT CHIP 100UF	20.00% 16V	FB1365	1-216-864-91	SHORT CHIP 0	
C1414	1-112-777-11	CERAMIC CHIP 0.01UF	10% 25V	FB1371	1-216-864-91	SHORT CHIP 0	
* C1464	1-112-298-91	CERAMIC CHIP 1UF	10% 16V	FB1380	1-216-864-91	SHORT CHIP 0	
* C1501	1-112-298-91	CERAMIC CHIP 1UF	10% 16V	FB1390	1-216-864-91	SHORT CHIP 0	
* C1504	1-112-298-91	CERAMIC CHIP 1UF	10% 16V	FB1399	1-216-864-91	SHORT CHIP 0	
C1701	1-100-916-11	CERAMIC CHIP 0.1UF	10% 16V	FB1400	1-244-161-81	METAL CHIP 2.2 5% 1/16W	
C1702	1-100-916-11	CERAMIC CHIP 0.1UF	10% 16V	FB1450	1-216-295-91	SHORT CHIP 0	
C2400	1-112-777-11	CERAMIC CHIP 0.01UF	10% 25V	FB1454	1-216-295-91	SHORT CHIP 0	
C2401	1-100-916-11	CERAMIC CHIP 0.1UF	10% 16V	FB1456	1-216-295-91	SHORT CHIP 0	

BDP-BX58/S480/S483/S580

Ref-No.	Part No.	Part Description	Remarks	Ref-No.	Part No.	Part Description	Remarks
FB1458	1-216-295-91	SHORT CHIP	0			<TRANSISTOR>	
FB1460	1-216-295-91	SHORT CHIP	0	Q301	6-552-430-01	TR DRC5114E0L	
FB1462	1-216-295-91	SHORT CHIP	0	Q302	6-551-184-01	TRANSISTOR MCH6305-TL-E-S	
FB1466	1-216-295-91	SHORT CHIP	0	Q303	6-552-430-01	TR DRC5114E0L	
FB2400	1-244-161-81	METAL CHIP	2.2 5% 1/16W	Q304	6-552-430-01	TR DRC5114E0L	
		<FILTER>		Q305	6-552-430-01	TR DRC5114E0L	
FL301	1-234-939-21	FILTER, EMI REMOVAL (SMD)		Q702	6-551-714-01	TR INK0001AC1-T112-1	
FL302	1-234-939-21	FILTER, EMI REMOVAL (SMD)		Q1501	6-551-690-01	TRANSISTOR RT3N11M-TP-1	
		<IC>		Q1502	6-552-430-01	TR DRC5114E0L	
IC301	6-705-312-01	IC S-T111B33MC-OGSTFG				<RESISTOR>	
IC302	6-716-781-01	IC RT8252ALGSP		R102	1-208-887-81	METAL CHIP 1K 0.5% 1/16W	
IC303	6-705-313-01	IC S-T111B50MC-OHJTFG		R103	1-208-887-81	METAL CHIP 1K 0.5% 1/16W	
IC305	6-705-312-01	IC S-T111B33MC-OGSTFG		R106	1-218-941-81	METAL CHIP 100 5% 1/16W	
IC306	6-702-302-01	IC TK11133CSCL-G		R107	1-218-941-81	METAL CHIP 100 5% 1/16W	
				R108	1-208-668-11	RES, METAL FILM CHIP 240(1005)	
IC308	6-714-935-01	IC TPS54225PWPR					
IC309	6-714-890-01	IC MM1855AHBE		R109	1-208-668-11	RES, METAL FILM CHIP 240(1005)	
IC501	6-710-563-01	IC K9F2G08U0A-PCBOT		R110	1-216-864-91	SHORT CHIP 0	
IC501	6-713-909-01	IC HY27UF082G2B-TPCBDR		R206	1-218-941-81	METAL CHIP 100 5% 1/16W	
IC601	6-716-739-01	IC BD00GC0WEFJ-SE2		R207	1-218-941-81	METAL CHIP 100 5% 1/16W	
				R208	1-208-668-11	RES, METAL FILM CHIP 240(1005)	
IC603	6-716-739-01	IC BD00GC0WEFJ-SE2					
IC604	6-711-050-01	IC S-1170B50UC-OUJTFG		R302	1-218-977-81	METAL CHIP 100K 5% 1/16W	
IC704	6-702-302-01	IC TK11133CSCL-G		R304	1-218-953-81	METAL CHIP 1K 5% 1/16W	
IC705	6-705-337-01	IC TK11150CSCL-G		R305	1-218-953-81	METAL CHIP 1K 5% 1/16W	
IC903	6-714-846-01	IC WM8524GEDT/R		R307	1-218-953-81	METAL CHIP 1K 5% 1/16W	
				R309	1-218-953-81	METAL CHIP 1K 5% 1/16W	
IC1003	6-716-592-01	IC BH76071FJ-E2					
IC1203	6-716-778-01	IC R5F21357CN101FP		R312	1-208-715-11	RES, METAL FILM CHIP 22K(1005)	
IC1361	6-716-786-01	IC MM1685YNRE		R316	1-218-990-81	SHORT CHIP 0	
IC1401	6-714-902-01	IC TPIC1391DBTRG4		R321	1-208-923-81	METAL CHIP 33K 0.5% 1/16W	
IC1501	6-708-762-01	IC PQ200WNA1ZPH		R322	1-208-909-81	METAL CHIP 8.2K 0.5% 1/16W	
				R323	1-208-881-81	METAL CHIP 560 0.5% 1/16W	
IC2401	6-716-779-01	IC TPIC1405ADFDRG4					
		<JACK>		R327	1-218-953-81	METAL CHIP 1K 5% 1/16W	
J901	1-842-473-11	PIN JACK BLOCK 7P		R330	1-208-899-81	METAL CHIP 3.3K 0.5% 1/16W	
		<INDUCTOR>		R331	1-208-911-81	METAL CHIP 10K 0.5% 1/16W	
L302	1-400-789-21	INDUCTOR	2.2UH	R332	1-208-891-81	METAL CHIP 1.5K 0.5% 1/16W	
L303	1-457-995-11	INDUCTOR	10UH	R333	1-208-899-81	METAL CHIP 3.3K 0.5% 1/16W	
L305	1-400-789-21	INDUCTOR	2.2UH				
L306	1-400-789-21	INDUCTOR	2.2UH	R334	1-208-899-81	METAL CHIP 3.3K 0.5% 1/16W	
L308	1-400-788-21	INDUCTOR	1UH	R335	1-208-859-81	METAL CHIP 68 0.5% 1/16W	
				R336	1-218-967-81	METAL CHIP 15K 5% 1/16W	
L601	1-457-223-11	INDUCTOR	0UH	R337	1-218-953-81	METAL CHIP 1K 5% 1/16W	
L602	1-457-223-11	INDUCTOR	0UH	R339	1-218-990-81	SHORT CHIP 0	
L701	1-457-374-21	INDUCTOR	0UH				
L702	1-457-374-21	INDUCTOR	0UH	R340	1-218-953-81	METAL CHIP 1K 5% 1/16W	
L703	1-457-374-21	INDUCTOR	0UH	R343	1-218-953-81	METAL CHIP 1K 5% 1/16W	
				R345	1-218-990-81	SHORT CHIP 0	
L704	1-457-374-21	INDUCTOR	0UH	R346	1-218-990-81	SHORT CHIP 0	
				R347	1-218-967-81	METAL CHIP 15K 5% 1/16W	
		<FUSE>		R350	1-208-929-81	METAL CHIP 56K 0.5% 1/16W	
△ PS301	1-523-134-31	FUSE	2A 50V	R351	1-208-911-81	METAL CHIP 10K 0.5% 1/16W	
△ PS302	1-523-135-31	FUSE	3.15A 32V	R352	1-208-871-81	METAL CHIP 220 0.5% 1/16W	
△ PS1201	1-523-130-31	FUSE	0.5A 50V	R362	1-216-825-91	METAL CHIP 2.2K 5% 1/10W	
				R363	1-216-825-91	METAL CHIP 2.2K 5% 1/10W	
		<CONTACT TERMINAL>					
PT403	1-780-729-12	CONTACT TERMINAL		R370	1-208-891-81	METAL CHIP 1.5K 0.5% 1/16W	
		S480/S483		R371	1-218-957-81	METAL CHIP 2.2K 5% 1/16W	
PT406	1-780-729-12	CONTACT TERMINAL		R374	1-218-971-81	METAL CHIP 33K 5% 1/16W	
		S480/S483		R375	1-218-971-81	METAL CHIP 33K 5% 1/16W	
				R376	1-218-953-81	METAL CHIP 1K 5% 1/16W	

BDP-BX58/S480/S483/S580

<u>Ref.No.</u>	<u>Part No.</u>	<u>Part Description</u>	<u>Remarks</u>			<u>Ref.No.</u>	<u>Part No.</u>	<u>Part Description</u>	<u>Remarks</u>		
R404	1-218-952-81	METAL CHIP	820	5%	1/16W	R1012	1-208-867-81	METAL CHIP	150	0.5%	1/16W
R405	1-218-977-81	METAL CHIP	100K	5%	1/16W	R1028	1-220-169-81	METAL CHIP	75	5%	1/16W
R406	1-216-864-91	SHORT CHIP	0			R1029	1-220-169-81	METAL CHIP	75	5%	1/16W
R508	1-218-990-81	SHORT CHIP	0			R1030	1-220-169-81	METAL CHIP	75	5%	1/16W
R518	1-218-990-81	SHORT CHIP	0			R1031	1-220-169-81	METAL CHIP	75	5%	1/16W
R523	1-218-959-81	METAL CHIP	3.3K	5%	1/16W	R1032	1-218-990-81	SHORT CHIP	0		
R533	1-218-990-81	SHORT CHIP	0			R1033	1-218-990-81	SHORT CHIP	0		
R603	1-216-864-91	SHORT CHIP	0			R1034	1-218-990-81	SHORT CHIP	0		
R605	1-218-970-11	RES, CHIP 27K				R1035	1-218-990-81	SHORT CHIP	0		
R606	1-218-970-11	RES, CHIP 27K				R1043	1-218-990-81	SHORT CHIP	0		
R607	1-208-911-81	METAL CHIP	10K	0.5%	1/16W	R1044	1-218-990-81	SHORT CHIP	0		
R609	1-218-864-11	RES, CHIP 5.1K		(1608)		R1045	1-218-990-81	SHORT CHIP	0		
R610	1-218-864-11	RES, CHIP 5.1K		(1608)		R1046	1-218-990-81	SHORT CHIP	0		
R611	1-218-965-81	METAL CHIP	10K	5%	1/16W	R1110	1-218-965-81	METAL CHIP	10K	5%	1/16W
R612	1-218-970-11	RES, CHIP 27K				R1138	1-218-965-81	METAL CHIP	10K	5%	1/16W
R613	1-218-970-11	RES, CHIP 27K				R1142	1-218-965-81	METAL CHIP	10K	5%	1/16W
R614	1-208-911-81	METAL CHIP	10K	0.5%	1/16W	R1143	1-218-965-81	METAL CHIP	10K	5%	1/16W
R616	1-218-965-81	METAL CHIP	10K	5%	1/16W	R1144	1-218-965-81	METAL CHIP	10K	5%	1/16W
R621	1-218-990-81	SHORT CHIP	0	S580/BX58/BR4		R1146	1-218-965-81	METAL CHIP	10K	5%	1/16W
R622	1-218-990-81	SHORT CHIP	0	S580/BX58/BR4		R1150	1-218-965-81	METAL CHIP	10K	5%	1/16W
R641	1-218-965-81	METAL CHIP	10K	5%	1/16W	R1156	1-218-990-81	SHORT CHIP	0		
		S580/BX58/BR4				R1160	1-218-990-81	SHORT CHIP	0		
R702	1-208-887-81	METAL CHIP	1K	0.5%	1/16W	R1161	1-218-965-81	METAL CHIP	10K	5%	1/16W
R703	1-208-891-81	METAL CHIP	1.5K	0.5%	1/16W	R1162	1-218-965-81	METAL CHIP	10K	5%	1/16W
R730	1-218-973-81	METAL CHIP	47K	5%	1/16W	R1163	1-218-965-81	METAL CHIP	10K	5%	1/16W
R734	1-218-965-81	METAL CHIP	10K	5%	1/16W						
R735	1-218-956-81	METAL CHIP	1.8K	5%	1/16W	R1165	1-218-965-81	METAL CHIP	10K	5%	1/16W
R736	1-218-956-81	METAL CHIP	1.8K	5%	1/16W	R1169	1-218-965-81	METAL CHIP	10K	5%	1/16W
R738	1-218-965-81	METAL CHIP	10K	5%	1/16W	R1171	1-218-965-81	METAL CHIP	10K	5%	1/16W
R747	1-218-990-81	SHORT CHIP	0								
R755	1-208-715-11	RES, METAL FILM CHIP 22K(1005)				R1180	1-218-953-81	METAL CHIP	1K	5%	1/16W
								S580: BR4			
R756	1-208-715-11	RES, METAL FILM CHIP 22K(1005)				R1189	1-218-977-81	METAL CHIP	100K	5%	1/16W
R806	1-208-920-81	METAL CHIP	24K	0.5%	1/16W	R1194	1-218-965-81	METAL CHIP	10K	5%	1/16W
R903	1-218-941-81	METAL CHIP	100	5%	1/16W						
R916	1-218-949-81	METAL CHIP	470	5%	1/16W	R1195	1-218-990-81	SHORT CHIP	0		
R917	1-218-949-81	METAL CHIP	470	5%	1/16W	R1198	1-208-903-81	METAL CHIP	4.7K	0.5%	1/16W
						R1199	1-208-903-81	METAL CHIP	4.7K	0.5%	1/16W
R922	1-218-944-81	METAL CHIP	180	5%	1/16W	R1202	1-218-941-81	METAL CHIP	100	5%	1/16W
R935	1-218-990-81	SHORT CHIP	0								
R936	1-216-864-91	SHORT CHIP	0			R1203	1-218-965-81	METAL CHIP	10K	5%	1/16W
R938	1-218-990-81	SHORT CHIP	0			R1206	1-218-970-11	RES, CHIP 27K			
R939	1-218-990-81	SHORT CHIP	0			R1208	1-218-965-81	METAL CHIP	10K	5%	1/16W
						R1212	1-218-981-81	METAL CHIP	220K	5%	1/16W
R940	1-469-082-21	FERRITE	0UH			R1213	1-218-965-81	METAL CHIP	10K	5%	1/16W
R942	1-218-990-81	SHORT CHIP	0								
R944	1-218-990-81	SHORT CHIP	0			R1220	1-218-961-81	METAL CHIP	4.7K	5%	1/16W
R952	1-218-990-81	SHORT CHIP	0			R1221	1-218-941-81	METAL CHIP	100	5%	1/16W
R954	1-218-990-81	SHORT CHIP	0			R1224	1-218-965-81	METAL CHIP	10K	5%	1/16W
						R1233	1-218-941-81	METAL CHIP	100	5%	1/16W
R955	1-242-967-81	METAL CHIP	1	5%	1/16W	R1234	1-218-941-81	METAL CHIP	100	5%	1/16W
R964	1-208-879-81	METAL CHIP	470	0.5%	1/16W						
R965	1-218-990-81	SHORT CHIP	0			R1235	1-218-977-81	METAL CHIP	100K	5%	1/16W
R966	1-208-879-81	METAL CHIP	470	0.5%	1/16W	R1236	1-218-977-81	METAL CHIP	100K	5%	1/16W
R976	1-218-973-81	METAL CHIP	47K	5%	1/16W	R1238	1-218-977-81	METAL CHIP	100K	5%	1/16W
						R1240	1-218-941-81	METAL CHIP	100	5%	1/16W
R977	1-218-973-81	METAL CHIP	47K	5%	1/16W	R1242	1-218-941-81	METAL CHIP	100	5%	1/16W
R985	1-218-990-81	SHORT CHIP	0								
R1005	1-208-881-81	METAL CHIP	560	0.5%	1/16W	R1243	1-218-965-81	METAL CHIP	10K	5%	1/16W
R1007	1-208-867-81	METAL CHIP	150	0.5%	1/16W	R1244	1-218-977-81	METAL CHIP	100K	5%	1/16W
R1008	1-208-867-81	METAL CHIP	150	0.5%	1/16W	R1246	1-218-965-81	METAL CHIP	10K	5%	1/16W
						R1249	1-218-965-81	METAL CHIP	10K	5%	1/16W
R1009	1-208-867-81	METAL CHIP	150	0.5%	1/16W	R1251	1-218-977-81	METAL CHIP	100K	5%	1/16W

<u>Ref-No.</u>	<u>Part No.</u>	<u>Part Description</u>	<u>Remarks</u>
R1256	1-208-897-81	METAL CHIP 2.7K 0.5%	1/16W
R1261	1-218-965-81	METAL CHIP 10K 5%	1/16W
R1262	1-218-977-81	METAL CHIP 100K 5%	1/16W
R1263	1-218-977-81	METAL CHIP 100K 5%	1/16W
R1264	1-218-981-81	METAL CHIP 220K 5%	1/16W
R1300	1-208-920-81	METAL CHIP 24K 0.5%	1/16W
R1310	1-218-957-81	METAL CHIP 2.2K 5%	1/16W
R1312	1-218-961-81	METAL CHIP 4.7K 5%	1/16W
R1334	1-208-911-81	METAL CHIP 10K 0.5%	1/16W
R1345	1-218-990-81	SHORT CHIP 0	
R1363	1-218-965-81	METAL CHIP 10K 5%	1/16W
R1386	1-218-965-81	METAL CHIP 10K 5%	1/16W
R1389	1-216-864-91	SHORT CHIP 0	
R1391	1-218-953-81	METAL CHIP 1K 5%	1/16W
R1392	1-218-954-81	METAL CHIP 1.2K 5%	1/16W
R1398	1-218-990-81	SHORT CHIP 0	
R1407	1-218-973-81	METAL CHIP 47K 5%	1/16W
R1412	1-218-973-81	METAL CHIP 47K 5%	1/16W
R1504	1-218-953-81	METAL CHIP 1K 5%	1/16W
R1507	1-208-899-81	METAL CHIP 3.3K 0.5%	1/16W
R1508	1-218-948-11	RES, CHIP 390	
R1509	1-208-683-11	RES,METAL FILM CHIP 1.0K(1005)	
R1510	1-208-889-81	METAL CHIP 1.2K 0.5%	1/16W
R1525	1-208-888-81	METAL CHIP 1.1K 0.5%	1/16W
R1602	1-218-990-81	SHORT CHIP 0	
R1603	1-218-990-81	SHORT CHIP 0	
R2442	1-218-853-91	METAL CHIP 1.8K 0.5%	1/10W
R2444	1-218-853-91	METAL CHIP 1.8K 0.5%	1/10W
R2446	1-218-853-91	METAL CHIP 1.8K 0.5%	1/10W
R2447	1-248-476-11	RES-CHIP 0.16 1%	1/3W
R2492	1-218-853-91	METAL CHIP 1.8K 0.5%	1/10W
R2494	1-218-853-91	METAL CHIP 1.8K 0.5%	1/10W
R2496	1-218-853-91	METAL CHIP 1.8K 0.5%	1/10W
		<VARIABLE RESISTOR>	
RB1101	1-234-378-21	RES, NETWORK 10K (1005X4)	
RB1102	1-234-378-21	RES, NETWORK 10K (1005X4)	
RB1201	1-234-372-21	RES, NETWORK 100 (1005X4)	
RB1202	1-234-378-21	RES, NETWORK 10K (1005X4)	
		<SWITCH>	
S1201	1-786-675-11	TACTILE SWITCH S580: BR4	
		<THERMISTOR>	
TH1201	1-804-949-11	THERMISTOR, NTC (SMD)	